



We,

Hisense International Co., Ltd
Hisense (Shandong) Air-conditioning Co.,Ltd.

No.8 Ronggang Road, Ronggui, Shunde, Foshan, Guangdong, P.R.China
No.1 Hisense Road, Nancun, Pingdu, Qingdao, Shandong Province, P.R.China
(Supplier Address & Factory Address)

declare under our sole responsibility that the product

AIR CONDITIONER
(Category Name)

GBF18H-S	GDF18H-S	GFF18H-S	GCF18H-S
GBF24H-S	GDF24H-S	GFF24H-S	GCF24H-S
GBF36H-S	GDF36H-S	GFF36H-S	GCF36H-S
GBF48H-S	GDF48H-S	GFF48H-S	GCF48H-S
GBF60H-S	GDF60H-S	GFF60H-S	GCF60H-S

(Model Name)

to which this declaration relates is in conformity with the technical requirements of the following standard(s)

EMC Directive- 2014/30/EU

Low Voltage Directive-2014/35/EU

CE Marking Directive-93/68/EEC

LVD standard

EN 60335-1:2012+A11:2014

EN 60335-2-40:2003

+A11:2004+A12:2005+A1:2006+A2:2009

+A13:2012

EN 62233:2008

EMC standard

EN 55014-1:2006

+A1:2009+A2:2011

EN 55014-2:1997 +A1:2001+A2:2008

EN 61000-3-2:2014

EN 61000-3-2:2014

EN 61003-3-3:2013



We, hereby further declare that the following products (Product catalog) are exactly the same, only difference being the art work.

Factory Model No.	Client Model No.	Brand	Type/Description/Feature
AUC-18HR4SAA	GBF18H-S	Galactic	R410a, On/Off, 18000Btu,CASSETTE type indoor unit
AUC-24HR4SGA	GBF24H-S	Galactic	R410a, On/Off, 24000Btu,CASSETTE type indoor unit
AUC-36HR4SGA	GBF36H-S	Galactic	R410a, On/Off, 36000Btu,CASSETTE type indoor unit
AUC-48HR4SHA	GBF48H-S	Galactic	R410a, On/Off, 48000Btu,CASSETTE type indoor unit
AUC-60HR4 SHA	GBF60H-S	Galactic	R410a, On/Off, 60000Btu,CASSETTE type indoor unit
AUD-18HX4SNL	GDF18H-S	Galactic	R410a, On/Off, 18000Btu,DUCT type indoor unit
AUD-24HX4SLH	GDF24H-S	Galactic	R410a, On/Off, 24000Btu,DUCT type indoor unit
AUD-36HX4S1HH	GDF36H-S	Galactic	R410a, On/Off, 36000Btu,DUCT type indoor unit
AUD-48HX4SHH	GDF48H-S	Galactic	R410a, On/Off, 48000Btu,DUCT type indoor unit
AUD-60HX4SHH	GDF60H-S	Galactic	R410a, On/Off, 60000Btu,DUCT type indoor unit
AUV-18HR4SA	GFF18H-S	Galactic	R410a, On/Off, 18000Btu,FLOOR-CEILING type indoor unit
AUV-24HR4SA	GFF24H-S	Galactic	R410a, On/Off, 24000Btu,FLOOR-CEILING type indoor unit
AUV-36HR4SB	GFF36H-S	Galactic	R410a, On/Off, 36000Btu,FLOOR-CEILING type indoor unit
AUV-48HR4SC	GFF48H-S	Galactic	R410a, On/Off, 48000Btu,FLOOR-CEILING type indoor unit
AUV-60HR4SC	GFF60H-S	Galactic	R410a, On/Off, 60000Btu,FLOOR-CEILING type indoor unit
AUW-18H4SU1	GCF18H-S	Galactic	R410a, On/Off, 18000Btu,universal outdoor unit
AUW-24H4SZ1	GCF24H-S	Galactic	R410a, On/Off, 24000Btu,universal outdoor unit
AUW-36H6S1A1	GCF36H-S	Galactic	R410a, On/Off, 36000Btu,universal outdoor unit
AUW-48H6SE1	GCF48H-S	Galactic	R410a, On/Off, 48000Btu,universal outdoor unit
AUW-60H6SP1	GCF60H-S	Galactic	R410a, On/Off, 60000Btu,universal outdoor unit

King Huang
Name of authorized officer
2017-03-12
Date of issue

Product Manager
Title of authorized officer
Signature & company seal

1. GENERAL

1-1 Features

Duct Type Air Conditioner



Features

➤ Save Installation Space

The indoor unit can be installed inside the ceiling conveniently.

➤ Optional Static Pressure

18k: optional 10Pa /30Pa, 24K/36K 50Pa/80Pa 48K/60K: 80Pa/120Pa static Pressure.

One unit, mute optional installation method.

➤ High Efficiency and Environment Friendly New Refrigerant-R410A

R410A can protect the environment and do not harm to the ozone layer.

➤ 24-hour Timer ON and OFF

This Timer can be set to automatically turn the unit on or off within a 24-hour period.

➤ Mute Operation

The excellent fan design enable the airflow to be quiet and smooth with minimum noise.

➤ Meeting Various Installation Requirements

The back-air-inlet type is usually to be adopted according to the actual installation space.

The unit is also installed with down-air-inlet type and the noise will increase about 5-6 dB.

1. GENERAL

➤ Self Recovery of Power Break

When the power supply is recovered after break, all preset are still effective and the air-conditioner can run according to the original setting.

➤ Fault Self-diagnose Function

When there is something wrong with the air-conditioner , the micro computer could diagnose the faults, which can be read from the display and is convenient for maintenance.



1. GENERAL

Cassette Type Air Conditioner

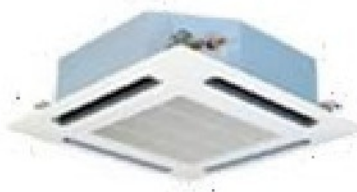

Features

➤ Save Installation Space

The indoor unit can be installed inside the ceiling conveniently.

➤ High Efficiency and Environment Friendly New Refrigerant-R410A

R410A can protect the environment and do not harm to the ozone layer.

➤ 24-hour Timer ON and OFF

This Timer can be set to automatically turn the unit on or off within a 24-hour period.

➤ Mute Operation

The excellent fan design enable the airflow to be quiet and smooth with minimum noise.

➤ Self Recovery of Power Break

When the power supply is recovered after break, all preset are still effective and the air-conditioner can run according to the original setting.

➤ Fault Self-diagnose Function

When there is something wrong with the air-conditioner, the micro computer could diagnose the faults, which can be read from the display and is convenient for maintenance.

1. GENERAL

Ceiling & Floor Air Conditioner



Features

- Save Installation Space

The indoor unit's thickness is only 230mm, can be installed inside the ceiling conveniently.

- Flexible Installation Options

According to the actual installation space, The indoor unit can be installed in the ceiling or on the floor. One unit, Two installation method.

- High Efficiency and Environment Friendly

New Refrigerant-R410A

R410A can protect the environment and do not harm to the ozone layer.

- 24-hour Timer ON and OFF

This Timer can be set to automatically turn the unit on or off within a 24-hour period.

- Mute Operation

The excellent fan design enable the airflow to be quiet and smooth with minimum noise.

- Various Refrigerant Pipe Connect Methods

The refrigerant pipe can be connect from 3 different directions(rear, right or top) .More methods, more conveniently.

- Self Recovery of Power Break

When the power supply is recovered after break, all preset are still effective and the air-conditioner can run according to the original setting.

- Fault Self-diagnose Function

1. GENERAL

When there is something wrong with the air-conditioner, the micro computer could diagnose the faults, which can be read from the display and is convenient for maintenance.



1. GENERAL

1-2 Product Lineup

Type	Model	18	24	36	48	60
Duct Type	AUD-	●	●	●	●	●
Cassette Type	AUC-	●	●	●	●	●
Ceiling&Floor type	AUV-	●	●	●	●	●



1. GENERAL

1-3 MODEL IDENTIFICATION

A U C -18 U R 4 S Z A A 1

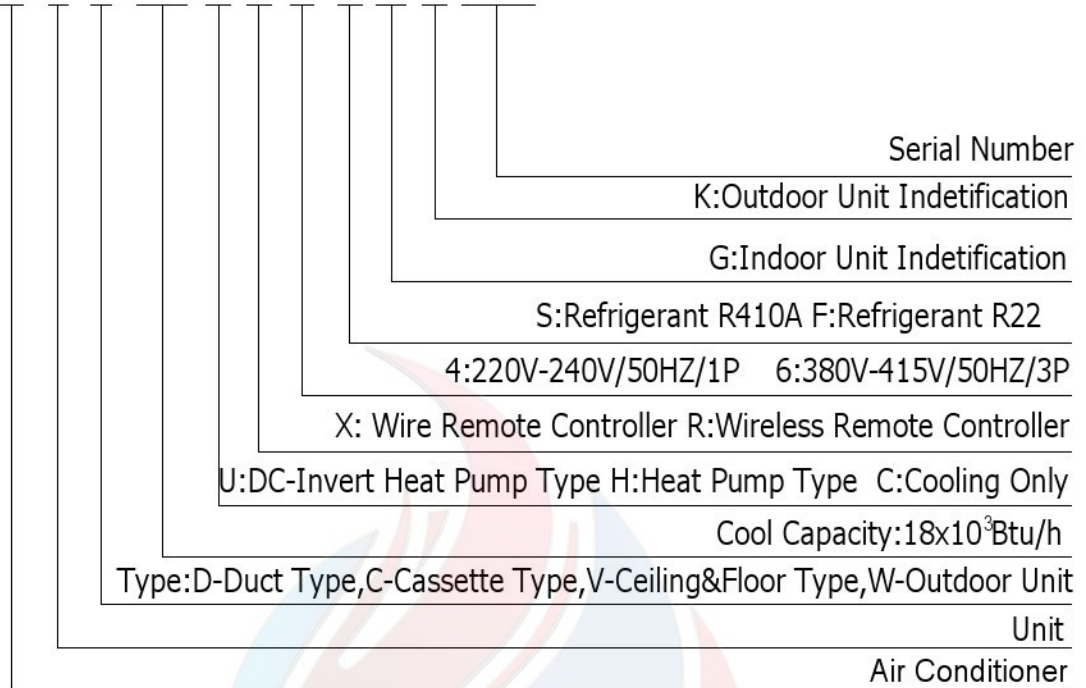

1. GENERAL

1-4 Product Picture

Duct Type

Model	AUD-18HX4SUNL AUD-18HX4SUNL1	AUD-24HX4SZLH AUD-24HX4SZLH1	AUD-36HX6SAHH AUD-36HX6SAHH1 AUD-36HX6S1A1HH1
Indoor			
Outdoor			
Model	AUD-48HX6SEHH1	AUD-48HX6SPHH AUD-60HX6SPHH AUD-60HX6SPHH1	
Indoor			
Outdoor			

1. GENERAL

Cassette Type

Model	AUC-18HR4SUAA AUC-18HR4SUAA1	AUC-24HR4SZGA AUC-24HR4SZGA1	AUC-36HR6SAGA AUC-36HR6SAGA1 AUC-36HR6S1AGA1
Indoor			
Outdoor			
Model	AUC-48HR6SEHA1	AUC-48HR6SPHA AUC-60HR6SPHA AUC-60HR6SPHA1	
Indoor			
Outdoor			

1. GENERAL

Ceiling&Floor Type

Model	AUV-18HR4SUA AUV-18HR4SUA1	AUV-24HR4SZA AUV-24HR4SZA1	AUV-36HR6SAB AUV-36HR6SAB1 AUV-36HR6S1AB1
Indoor			
Outdoor			
Model	AUV-48HR6SEC1	AUV-48HR6SPC AUV-60HR6SPC AUV-60HR6SPC1	
Indoor			
Outdoor			

1. GENERAL

DISPLAY PANEL

Cassette Type

18k

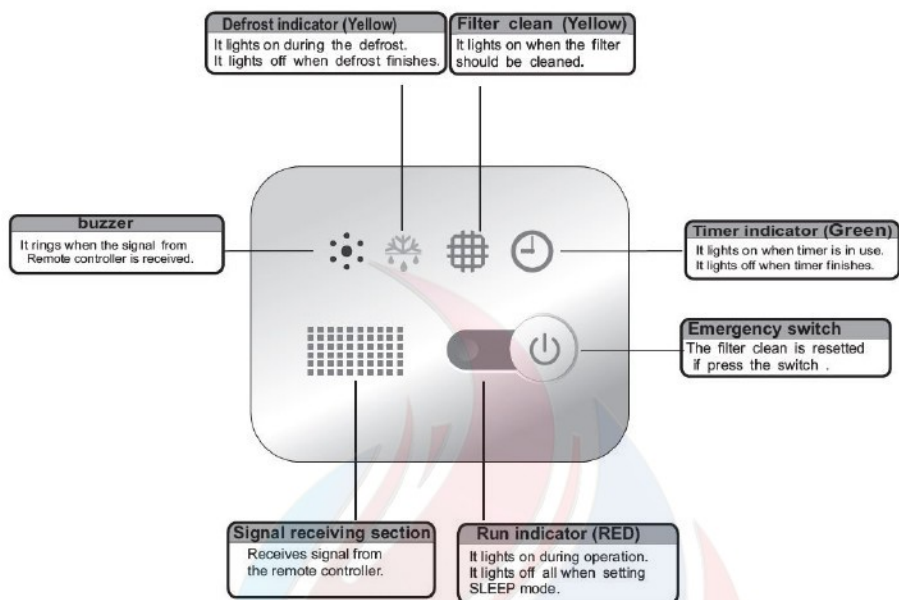

24K, 36K, 48K, 60K

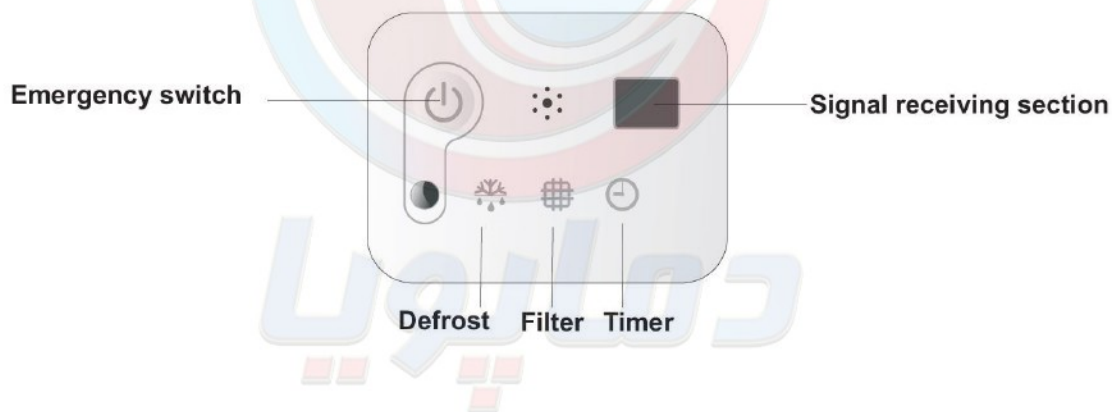

1. GENERAL

Ceiling&Floor type

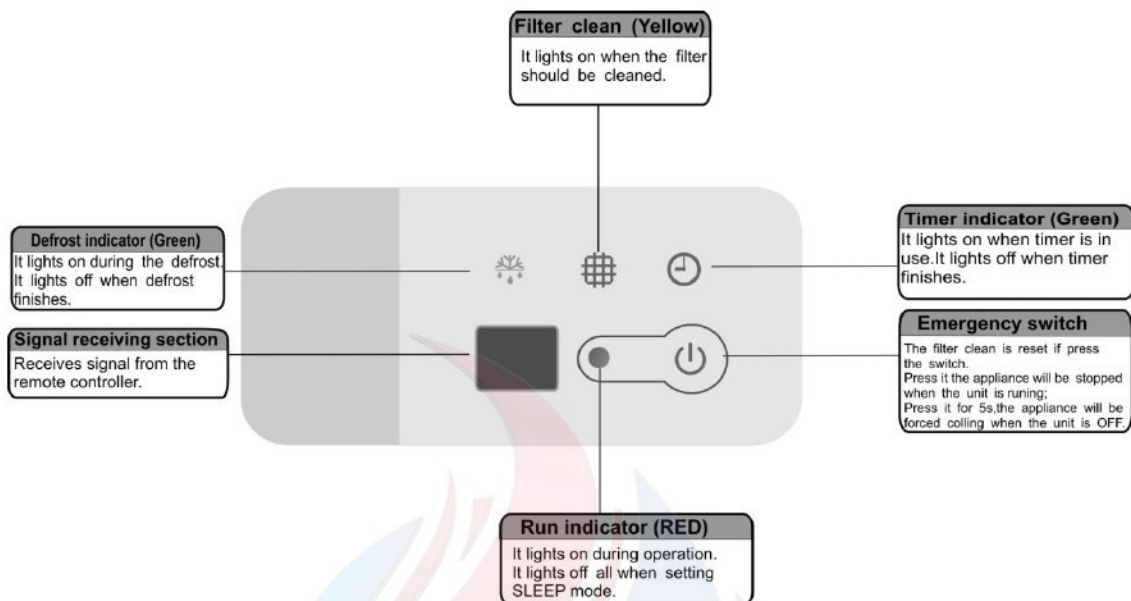

دما پویا

2. SPECIFICATIONS

2. Specifications

2.1 Duct Type

On/Off Unitary Indoor Unit

		AUD-18HX4SUNL	AUD-24HX4SZLH	AUD-36HX6SAHH	AUD-48HX6SPHH	AUD-60HX6SPHH
Indoor model:		AUD-18HX4SNL	AUD-24HX4SLH	AUD-36HX4SHH	AUD-48HX4SHH	AUD-60HX4SHH
Outdoor model:		AUW-18H4SU	AUW-24H4SZ	AUW-36H6SA	AUW-48H6SP	AUW-60H6SP
Performance						
Cooling Capacity (W)		5000	7400	10200	14000	16000
Heating Capacity (W)		5500	7900	11250	15000	17500
Rated Input (w)	Cooling	1550	2450	3625	4651	5694
	Heating	1600	2190	3295	4532	5814
Air Circulation (m ³ /h)		710	1100	1800	2000	2000
EER for Cooling (w/w)		3.23	3.02	2.81	3.01	2.81
Energy Class		A	B	C	B	C
COP for Heating (w/w)		3.44	3.61	3.41	3.31	3.01
Energy Class		B	A	B	C	D
ESP (Pa)		10(30)	50(80)	50(80)	80(120)	80(120)
Power Supply						
Volt/Phase/Hz		220-240V~/1P/50 Hz	220-240V~/1P/50 Hz	220-240V~/1P/50 Hz	220-240V~/1P/50 Hz	220-240V~/1P/50 Hz
Rated Current (A)	Cooling	7.1	11.5	6.5	8.8	10.0
	Heating	7.3	11.0	6.1	8.6	10.3
Noise Level (dB (A))	Indoor Unit	H/M/ L	37/35/32	40/38/36	40/38/36	46/44/42
Piping						
Diameter(Liquid)	Inch	1/4	3/8	3/8	3/8	3/8
Diameter(Gas)	Inch	1/2	5/8	5/8	3/4	3/4
Max Length	m	20	30	30	50	50
Max Height	m	15	15	20	30	30
System						
Compressor type		Rotary	Rotary	SCROLL	SCROLL	SCROLL
Compressor MFG		GMCC	GMCC	SANYO	SANYO	SANYO
Expansion Device		capillary	capillary	capillary	CAPILLARY	CAPILLARY
Evaporator		Copper tube and Aluminum Fin	Copper tube and Aluminum Fin	Copper tube and Aluminum Fin	Copper tube and Aluminum Fin	Copper tube and Aluminum Fin
Condenser		Copper tube and Aluminum Fin	Copper tube and Aluminum Fin	Copper tube and Aluminum Fin	Copper tube and Aluminum Fin	Copper tube and Aluminum Fin
Other						

2. SPECIFICATIONS

		AUD-18HX4SUNL	AUD-24HX4SZLH	AUD-36HX6SAHH	AUD-48HX6SPHH	AUD-60HX6SPHH
Indoor model:		AUD-18HX4SNL	AUD-24HX4SLH	AUD-36HX4SHH	AUD-48HX4SHH	AUD-60HX4SHH
Outdoor model:		AUW-18H4SU	AUW-24H4SZ	AUW-36H6SA	AUW-48H6SP	AUW-60H6SP
Dimensions WxHxD (mm)	Indoor Unit	900×190×447	900×270 ×720	1386×350×800	1386×350×800	1386×350×800
Net Weight (Kg)	Indoor Unit	19	32	54	54	54
Packing Dimensions WxHxD (mm)	Indoor Unit	1070X236X580	1170X340X870	1550×410×940	1550×410×940	1550×410×940
Gross Weight (Kg)	Indoor Unit	24	37	62	62	62

Test conditions:

Cooling : Indoor: DB27 °C / WB19 °C Outdoor: DB35 °C / WB24 °C

Heating: Indoor: DB20 °C / WB15 °C Outdoor: DB7 °C / WB 6 °C

Remarks:

1. The above design and specifications are subject to change without prior notice for product improvement.
2. The values given in the table for noise level reflect the levels in anechoic chamber.

This heat pump air conditioner has been designed for the following temperatures.

Operate the heat pump air conditioner within this range.

	Outdoor Working Temperature(°C)	
	Maximum	Minimum
Cooling Operation	43	15
Heating Operation	24	-10

Storage condition: Temperature -20~65°C

Humidity 30%~80%

2. SPECIFICATIONS

On/Off Unitary Indoor Unit (Low temp.)

		AUD-18HX4SU NL1	AUD-24HX4SZL H1	AUD-36HX6SA HH1	AUD-36HX6S1A 1HH1	AUD-48HX6SE HH1	AUD-60HX6S PHH1
Indoor model:		AUD-18HX4SN L	AUD-24HX4SL H	AUD-36HX4SH H	AUD-36HX4S1H H	AUD-48HX4SH H	AUD-60HX4S HH
Outdoor model:		AUW-18H4SU1	AUW-24H4SZ1	AUW-36H6SA1	AUW-36H6S1A 1	AUW-48H6SE1	AUW-60H6SP 1
Performance							
Cooling Capacity (W)		5000	7400	10200	10200	14000	16000
Heating Capacity (W)		5500	7900	11250	11250	15000	17500
Rated Input (w)	Cooling	1550	2450	3625	3625	4651	5694
	Heating	1600	2190	3295	3295	4532	5814
Air Circulation (m ³ /h)		710	1100	1800	1800	2000	2000
EER for Cooling (w/w)		3.23	3.02	2.81	2.81	3.01	2.81
Energy Class		A	B	C	C	B	C
COP for Heating (w/w)		3.44	3.61	3.41	3.41	3.31	3.01
Energy Class		B	A	B	B	C	D
ESP (Pa)		10(30)	50(80)	50(80)	50(80)	80(120)	80(120)
Power Supply							
Volt/Phase/Hz		220-240V~1P/5 0Hz	220-240V~1P/5 0Hz	220-240V~1P/5 0Hz	220-240V~1P/5 0Hz	220-240V~1P/5 0Hz	220-240V~1P /50Hz
Rated Current (A)	Cooling	7.1	11.5	6.5	6.5	8.8	10.0
	Heating	7.3	11.0	6.1	6.1	8.6	10.3
Noise Level (dB (A))	Indoor Unit	H/M/ L	37/35/32	40/38/36	40/38/36	40/38/36	46/44/42
Piping							
Diameter(Liquid)	Inch	1/4	3/8	3/8	3/8	3/8	3/8
Diameter(Gas)	Inch	1/2	5/8	5/8	5/8	3/4	3/4
Max Length	m	20	30	30	30	50	50
Max Height	m	15	15	20	20	30	30
System							
Compressor type		Rotary	Rotary	SCROLL	Rotary	Rotary	Rotary
Compressor MFG		GMCC	GMCC	SANYO	Highly	Highly	Highly
Expansion Device		capillary	capillary	capillary	CAPILLARY	CAPILLARY	CAPILLARY
Evaporator		Copper tube and Aluminum Fin	Copper tube and Aluminum Fin	Copper tube and Aluminum Fin	Copper tube and Aluminum Fin	Copper tube and Aluminum Fin	Copper tube and Aluminum Fin
Condenser		Copper tube and Aluminum Fin	Copper tube and Aluminum Fin	Copper tube and Aluminum Fin	Copper tube and Aluminum Fin	Copper tube and Aluminum Fin	Copper tube and Aluminum Fin
Other							

2. SPECIFICATIONS

		AUD-18HX4SU NL1	AUD-24HX4SZL H1	AUD-36HX6SA HH1	AUD-36HX6S1A 1HH1	AUD-48HX6SE HH1	AUD-60HX6S PHH1
Indoor model:		AUD-18HX4SN L	AUD-24HX4SL H	AUD-36HX4SH H	AUD-36HX4S1H H	AUD-48HX4SH H	AUD-60HX4S HH
Outdoor model:		AUW-18H4SU1	AUW-24H4SZ1	AUW-36H6SA1	AUW-36H6S1A 1	AUW-48H6SE1	AUW-60H6SP 1
Dimensions WxHxD (mm)	Indoor Unit	900×190×447	900×270 ×720	1386×350×800	1386×350×800	1386×350×800	1386×350×80 0
Net Weight (Kg)	Indoor Unit	19	32	54	54	54	54
Packing Dimensions WxHxD (mm)	Indoor Unit	1070×236×580	1170×340×870	1550×410×940	1550×410×940	1550×410×940	1550×410×94 0
Gross Weight (Kg)	Indoor Unit	24	37	62	62	62	62
Loading Capacity (20/40/40' HC)		76/160/180	36/80/94	23/50/56	23/50/56	23/50/56	19/40/42

Test conditions:

Cooling : Indoor: DB27 °C / WB19 °C Outdoor: DB35 °C / WB24 °C

Heating: Indoor: DB20 °C / WB15 °C Outdoor: DB7 °C / WB 6 °C

Remarks:

- 1.The above design and specifications are subject to change without prior notice for product improvement.
- 2.The values given in the table for noise level reflect the levels in anechoic chamber.

This heat pump air conditioner has been designed for the following temperatures.

Operate the heat pump air conditioner within this range.

	Outdoor Working Temperature(°C)	
	Maximum	Minimum
Cooling Operation	43	-15
Heating Operation	24	-10

Storage condition: Temperature -20~65°C

Humidity 30%~80%

2. SPECIFICATIONS

2.2 Cassette Type

On/Off Unitary Indoor Unit

		AUC-18HR4SUA A	AUC-24HR4SZ GA	AUC-36HR6SA GA	AUC-48HR6SP HA	AUC-60HR6SPHA
Indoor model:		AUC-18HR4SAA	AUC-24HR4SG A	AUC-36HR4SG A	AUC-48HR4SH A	AUC-60HR4SHA
Outdoor model:		AUW-18H4SU	AUW-24H4SZ	AUW-36H6SA	AUW-48H6SP	AUW-60H6SP
Performance						
Cooling Capacity (W)		5000	7450	10000	14000	16000
Heating Capacity (W)		5500	7500	11000	14800	17500
Rated Input (w)	Cooling	1550	2320	3550	4650	5694
	Heating	1550	2080	3225	4853	5814
Air Circulation (m3/h)		800	1100	1800	2000	2000
EER for Cooling (w/w)		3.23	3.21	2.81	3.01	2.81
Energy Class		A	A	C	B	C
COP for Heating (w/w)		3.55	3.61	3.41	3.05	3.01
Energy Class		B	A	B	D	D
ESP (Pa)						
Power Supply						
Volt/Phase/Hz		220-240V~1P/50 Hz	220-240V~1P/5 0Hz	220-240V~1P/5 0Hz	220-240V~1P/5 0Hz	220-240V~1P/50 Hz
Rated Current (A)	Cooling	7.1	10.8	6.0	8.9	10.0
	Heating	7.1	10.0	5.7	9.3	10.3
Noise Level (dB (A))	Indoor Unit H/M/L	46/42/39	43/38/30	50/47/44	50/45/40	50/45/40
Piping						
Diameter(Liquid)	Inch	1/4	3/8	3/8	3/8	3/8
Diameter(Gas)	Inch	1/2	5/8	5/8	3/4	3/4
Max Length	m	20	30	30	50	50
Max Height	m	15	15	20	30	30
System						
Compressor type		Rotary	Rotary	SCROLL	SCROLL	SCROLL
Compressor Model No.		PA190M2CS-4K TL	PA290G2CS-4 MUL1	C-SBN303H8D	C-SBN373H8D	C-SBN453H8D
Compressor MFG		GMCC	GMCC	SANYO	SANYO	SANYO
Expansion Device		capillary	capillary	capillary	CAPILLARY	CAPILLARY
Evaporator		Copper tube and Aluminum Fin	Copper tube and Aluminum Fin	Copper tube and Aluminum Fin	Copper tube and Aluminum Fin	Copper tube and Aluminum Fin

2. SPECIFICATIONS

		AUC-18HR4SUA A	AUC-24HR4SZ GA	AUC-36HR6SA GA	AUC-48HR6SP HA	AUC-60HR6SPHA
Indoor model:		AUC-18HR4SAA	AUC-24HR4SG A	AUC-36HR4SG A	AUC-48HR4SH A	AUC-60HR4SHA
Outdoor model:		AUW-18H4SU	AUW-24H4SZ	AUW-36H6SA	AUW-48H6SP	AUW-60H6SP
Condenser		Copper tube and Aluminum Fin	Copper tube and Aluminum Fin	Copper tube and Aluminum Fin	Copper tube and Aluminum Fin	Copper tube and Aluminum Fin
Other						
Dimensions WxHxD (mm)	Panel	650x30x650	950x37x950	950x37x950	950x37x950	950x37x950
	Indoor Unit	650x270x570	840x248x840	840x248x840	840x298x840	840x298x840
Net Weight (Kg)	Panel	2.4	6	6	6	6
	Indoor Unit	20	28	30	33	33
Packing Dimensions WxHxD (mm)	Panel	730x130x730	990x115x1010	990x115x1010	1010x115x990	1010x115x990
	Indoor Unit	770x310x750	930x290x930	930x290x930	930x340x930	930x340x930
Gross Weight (Kg)	Panel	5	7.5	7.5	7.5	7.5
	Indoor Unit	27	34	36	39	39
Loading Capacity (20/40/140' HC)		56/115/130	43/90/104	32/66/77	23/48/53	23/48/53

Test conditions:

Cooling : Indoor: DB27°C / WB19°C Outdoor: DB35°C / WB24°C

Heating: Indoor: DB20°C / WB15°C Outdoor: DB7°C / WB 6°C

Remarks:

- 1.The above design and specifications are subject to change without prior notice for product improvement.
- 2.The values given in the table for noise level reflect the levels in anechoic chamber.

This heat pump air conditioner has been designed for the following temperatures.
Operate the heat pump air conditioner within this range.

	Outdoor Working Temperature(°C)	
	Maximum	Minimum
Cooling Operation	43	15
Heating Operation	24	-10

Storage condition: Temperature -20~65°C

Humidity 30%~80%

2. SPECIFICATIONS

On/Off Unitary Indoor Unit(Low Temp.)

	AUC-18HR4SU AA1		AUC-24HR4S ZGA1		AUC-36HR6S AGA1		AUC-36HR6S 1AGA1		AUC-48HR6S EHA1		AUC-60HR6 SPHA1			
Indoor model:	AUC-18HR4SA A		AUC-24HR4S GA		AUC-36HR4S GA		AUC-36HR4S GA		AUC-48HR4S HA		AUC-60HR4 SHA			
Outdoor model:	AUW-18H4SU1		AUW-24H4SZ 1		AUW-36H6SA 1		AUW-36H6S1 A1		AUW-48H6SE 1		AUW-60H6 SP1			
Panel:	PE-BA-B29		PE-CA-B29		PE-CA-B29		PE-CA-B29		PE-CA-B29		PE-CA-B29			
Performance														
Cooling Capacity (W)		5000		7450		10000		10000		14000		16000		
Heating Capacity (W)		5500		7500		11000		11000		14800		17500		
Rated Input (w)	Cooling	1550		2320		3550		3550		4650		5694		
	Heating	1550		2080		3225		3225		4853		5814		
Air Circulation (m3/h)		800		1100		1800		1800		2000		2000		
EER for Cooling (w/w)		3.23		3.21		2.81		2.82		3.01		2.81		
Energy Class		A		A		C		C		B		C		
COP for Heating (w/w)		3.55		3.61		3.41		3.41		3.05		3.01		
Energy Class		B		A		B		B		D		D		
ESP (Pa)														
Power Supply														
Volt/Phase/Hz		220-240V~1P/5 0Hz		220-240V~1P /50Hz		220-240V~1P /50Hz		220-240V~1P /50Hz		220-240V~1P /50Hz		220-240V~1 1P/50Hz		
Rated Current (A)	Cooling	7.1		10.8		6.0		6.0		8.9		10.0		
	Heating	7.1		10.0		5.7		5.7		9.3		10.3		
Noise Level (dB (A))	Indoor Unit	H/M/ L	46/42/39		43/38/30		50/47/44		50/47/44		50/45/40		50/45/40	
Piping														
Diameter(Liquid)		Inch	1/4		3/8		3/8		3/8		3/8		3/8	
Diameter(Gas)		Inch	1/2		5/8		5/8		5/8		3/4		3/4	
Max Length		m	20		30		30		30		50		50	
Max Height		m	15		15		20		20		30		30	
System														
Compressor type		Rotary		Rotary		SCROLL		Rotary		Rotary		Rotary		
Compressor MFG		GMCC		GMCC		SANYO		Highly		Highly		Highly		
Expansion Device		capillary		capillary		capillary		CAPILLARY		CAPILLARY		CAPILLARY		
Evaporator		Copper tube and Aluminum Fin		Copper tube and Aluminum Fin		Copper tube and Aluminum Fin		Copper tube and Aluminum Fin		Copper tube and Aluminum Fin		Copper tube and Aluminum Fin		
Condenser		Copper tube and Aluminum Fin		Copper tube and Aluminum		Copper tube and Aluminum		Copper tube and Aluminum		Copper tube and Aluminum		Copper tube and		

2. SPECIFICATIONS

		AUC-18HR4SU AA1	AUC-24HR4S ZGA1	AUC-36HR6S AGA1	AUC-36HR6S 1AGA1	AUC-48HR6S EHA1	AUC-60HR6 SPHA1
Indoor model:		AUC-18HR4SA A	AUC-24HR4S GA	AUC-36HR4S GA	AUC-36HR4S GA	AUC-48HR4S HA	AUC-60HR4 SHA
Outdoor model:		AUW-18H4SU1	AUW-24H4SZ 1	AUW-36H6SA 1	AUW-36H6S1 A1	AUW-48H6SE 1	AUW-60H6 SP1
Panel:		PE-BA-B29	PE-CA-B29	PE-CA-B29	PE-CA-B29	PE-CA-B29	PE-CA-B29
			Fin	Fin	Fin	Fin	Aluminum Fin
Other							
Dimension s WxHxD (mm)	Panel	650x30x650	950x37x950	950x37x950	950x37x950	950x37x950	950x37x950
	Indoor Unit	650x270x570	840x248x840	840x248x840	840x248x840	840x298x840	840x298x840
Net Weight (Kg)	Panel	2.4	6	6	6	6	6
	Indoor Unit	20	28	30	30	33	33
Packing Dimension s WxHxD (mm)	Panel	730x130x730	990x115x1010	990x115x1010	990x115x1010	1010x115x990	1010x115x990
	Indoor Unit	770x310x750	930x290x930	930x290x930	930x290x930	930x340x930	930x340x930
Gross Weight (Kg)	Panel	5	10	10	10	10	10
	Indoor Unit	27	34	36	36	39	39

Test conditions:

Cooling : Indoor: DB27°C / WB19°C Outdoor: DB35°C / WB24°C

Heating : Indoor: DB20°C / WB15°C Outdoor: DB7°C / WB 6°C

Remarks:

1.The above design and specifications are subject to change without prior notice for product improvement.

2.The values given in the table for noise level reflect the levels in anechoic chamber.

This heat pump air conditioner has been designed for the following temperatures.

Operate the heat pump air conditioner within this range.

ON/OFF Unitary (Low Ambient Temperature Type)

	outdoor working temperature(°C)	
	maximum	minimum
Cooling Operation	43	-15
Heating Operation	24	-10

Storage condition: Temperature -20~65°C

Humidity 30%~80%

2. SPECIFICATIONS

2.3 Ceiling&Floor type

On/Off Unitary Indoor Unit

		AUV-18HR4SU A	AUV-24HR4S ZA	AUV-36HR6S AB	AUV-48HR6SP C	AUV-60HR6S PC
Indoor model:		AUV-18HR4SA	AUV-24HR4S A	AUV-36HR4S B	AUV-48HR4SC	AUV-60HR4S C
Outdoor model:		AUW-18H4SU	AUW-24H4SZ	AUW-36H6SA	AUW-48H6SP	AUW-60H6SP
Performance						
Cooling Capacity (W)		5000	7700	10200	14000	16000
Heating Capacity (W)		5500	7900	12000	16000	18000
Rated Input (w)	Cooling	1550	2400	3625	4651	5694
	Heating	1520	2190	3510	4532	5814
Air Circulation (m3/h)		800	1100	1800	2000	2000
EER for Cooling (w/w)		3.23	3.21	2.81	3.01	2.81
Energy Class		A	A	C	B	C
COP for Heating (w/w)		3.62	3.61	3.42	3.53	3.10
Energy Class		A	A	B	B	D
Power Supply						
Volt/Phase/Hz		220-240V~/1P/5 0Hz	220-240V~/1P /50Hz	220-240V~/1P /50Hz	220-240V~/1P/5 0Hz	220-240V~/1P /50Hz
Rated Current (A)	Cooling	7.1	11.2	6.7	8.8	10.0
	Heating	7.0	11.0	6.5	8.6	10.3
Noise Level (dB (A))	Indoor Unit	H/M/ L	41/38/35	52/48/45	53/52/50	53/52/50
Piping						
Diameter(Liquid)	Inch	1/4	3/8	3/8	3/8	3/8
Diameter(Gas)	Inch	1/2	5/8	5/8	3/4	3/4
Max Length	m	20	30	30	50	50
Max Height	m	15	15	20	30	30
System						
Compressor type		Rotary	Rotary	SCROLL	SCROLL	SCROLL
Compressor MFG		GMCC	GMCC	SANYO	SANYO	SANYO
Expansion Device		capillary	capillary	capillary	CAPILLARY	CAPILLARY
Evaporator		Copper tube and Aluminum Fin	Copper tube and Aluminum Fin	Copper tube and Aluminum Fin	Copper tube and Aluminum Fin	Copper tube and Aluminum Fin
Condenser		Copper tube and Aluminum Fin	Copper tube and Aluminum Fin	Copper tube and Aluminum Fin	Copper tube and Aluminum Fin	Copper tube and Aluminum Fin
Other						

2. SPECIFICATIONS

		AUV-18HR4SU A	AUV-24HR4S ZA	AUV-36HR6S AB	AUV-48HR6SP C	AUV-60HR6S PC
Indoor model:		AUV-18HR4SA	AUV-24HR4S A	AUV-36HR4S B	AUV-48HR4SC	AUV-60HR4S C
Outdoor model:		AUW-18H4SU	AUW-24H4SZ	AUW-36H6SA	AUW-48H6SP	AUW-60H6SP
Dimensions WxHxD (mm)	Indoor Unit	990x680x230	990x680x230	1285x680x230	1580x680x230	1580x680x230
Net Weight (Kg)	Indoor Unit	27	28	37	46	46
Packing Dimensions WxHxD (mm)	Indoor Unit	1100x820x350	1100x820x350	1400x820x350	1690x820x350	1690x820x350
Gross Weight (Kg)	Indoor Unit	33	34	44	54	54
Loading Capacity (20/40/140' HC)		55/116/122	45/99/105	33/67/74	22/47/50	22/47/50

Test conditions:

Cooling : Indoor: DB27°C/ WB19°C Outdoor: DB35°C/ WB24°C

Heating: Indoor: DB20°C/ WB15°C Outdoor: DB7°C/ WB 6°C

Remarks:

- 1.The above design and specifications are subject to change without prior notice for product improvement.
- 2.The values given in the table for noise level reflect the levels in anechoic chamber.

This heat pump air conditioner has been designed for the following temperatures.

Operate the heat pump air conditioner within this range.

	Outdoor Working Temperature(°C)	
	Maximum	Minimum
Cooling Operation	43	15
Heating Operation	24	-10

Storage condition: Temperature -20~65°C

Humidity 30%~80%

2. SPECIFICATIONS

On/Off Unitary Indoor Unit(Low Temp.)

		AUV-18HR4S UA1	AUV-24HR4S ZA1	AUV-36HR6S AB1	AUV-36HR6S 1AB1	AUV-48HR6S EC1	AUV-60HR6S PC1
Indoor model:		AUV-18HR4S A	AUV-24HR4S A	AUV-36HR4S B	AUV-36HR4S B	AUV-48HR4S C	AUV-60HR4S C
Outdoor model:		AUW-18H4SU 1	AUW-24H4SZ 1	AUW-36H6SA 1	AUW-36H6S1 A1	AUW-48H6SE 1	AUW-60H6SP 1
Performance							
Cooling Capacity (W)		5000	7700	10200	10200	14000	16000
Heating Capacity (W)		5500	7900	12000	12000	16000	18000
Rated Input (w)	Cooling	1550	2400	3625	3625	4651	5694
	Heating	1520	2190	3510	3510	4532	5814
Air Circulation (m3/h)		800	1100	1800	1800	2000	2000
EER for Cooling (w/w)		3.23	3.21	2.81	2.81	3.01	2.81
Energy Class		A	A	C	C	B	C
COP for Heating (w/w)		3.62	3.61	3.42	3.42	3.53	3.10
Energy Class		A	A	B	B	B	D
Power Supply							
Volt/Phase/Hz		220-240V~/1P /50Hz	220-240V~/1P /50Hz	220-240V~/1P /50Hz	220-240V~/1P /50Hz	220-240V~/1P /50Hz	220-240V~/1P /50Hz
Rated Current (A)	Cooling	7.1	11.2	6.7	6.7	8.8	10.0
	Heating	7.0	11.0	6.5	6.5	8.6	10.3
Noise Level (dB (A))	Indoor Unit	H/M/L 41/38/35	52/48/45	53/52/50	53/52/50	53/52/50	53/52/50
Piping							
Diameter(Liquid)	Inch	1/4	3/8	3/8	3/8	3/8	3/8
Diameter(Gas)	Inch	1/2	5/8	5/8	5/8	3/4	3/4
Max Length	m	20	30	30	30	50	50
Max Height	m	15	15	20	20	30	30
System							
Compressor type		Rotary	Rotary	SCROLL	Rotary	Rotary	Rotary
Compressor MFG		GMCC	GMCC	SANYO	Highly	Highly	Highly
Expansion Device		capillary	capillary	capillary	CAPILLARY	CAPILLARY	CAPILLARY
Evaporator		Copper tube and Aluminum Fin	Copper tube and Aluminum Fin	Copper tube and Aluminum Fin	Copper tube and Aluminum Fin	Copper tube and Aluminum Fin	Copper tube and Aluminum Fin
Condenser		Copper tube and Aluminum Fin	Copper tube and Aluminum Fin	Copper tube and Aluminum Fin	Copper tube and Aluminum Fin	Copper tube and Aluminum Fin	Copper tube and Aluminum Fin
Other							

2. SPECIFICATIONS

		AUV-18HR4S UA1	AUV-24HR4S ZA1	AUV-36HR6S AB1	AUV-36HR6S 1AB1	AUV-48HR6S EC1	AUV-60HR6S PC1
Indoor model:		AUV-18HR4S A	AUV-24HR4S A	AUV-36HR4S B	AUV-36HR4S B	AUV-48HR4S C	AUV-60HR4S C
Outdoor model:		AUW-18H4SU 1	AUW-24H4SZ 1	AUW-36H6SA 1	AUW-36H6S1 A1	AUW-48H6SE 1	AUW-60H6SP 1
Dimensions WxHxD (mm)	Indoor Unit	990x680x230	990x680x230	1285x680x230	1285x680x230	1580x680x230	1580x680x230
Net Weight (Kg)	Indoor Unit	27	28	37	37	46	46
Packing Dimensions WxHxD (mm)	Indoor Unit	1100x820x350	1100x820x350	1400x820x350	1400x820x350	1690x820x350	1690x820x350
Gross Weight (Kg)	Indoor Unit	33	34	44	44	54	54

Test conditions:

Cooling : Indoor: DB27 °C / WB19 °C Outdoor: DB35 °C / WB24 °C

Heating: Indoor: DB20 °C / WB15 °C Outdoor: DB7 °C / WB 6 °C

Remarks:

1.The above design and specifications are subject to change without prior notice for product improvement.

2.The values given in the table for noise level reflect the levels in anechoic chamber.

This heat pump air conditioner has been designed for the following temperatures.

Operate the heat pump air conditioner within this range.

ON/OFF Unitary (Low Ambient Temperature Type)

	outdoor working temperature(°C)	
	maximum	minimum
Cooling Operation	43	-15
Heating Operation	24	-10

Storage condition: Temperature -20~65°C

Humidity 30%~80%

2. SPECIFICATIONS

2.5 On/Off Unitary Universal Outdoor Unit

Outdoor Unit:		AUW-18H4S U	AUW-24H4SZ	AUW-36H6 SA	AUW-48H6SP	AUW-60H6SP
Performance						
Power Supply						
Volt/Phase/Hz		220-240V~/1P /50Hz	220-240V~/1P /50Hz	380~415V~/ 3Ph/50Hz	380~415V~/3 Ph/50Hz	380~415V~/3Ph/50 Hz
Rated Input (w)	Cooling	RFT IDU LABEL	RFT IDU LABEL	RFT IDU LABEL	RFT IDU LABEL	RFT IDU LABEL
	Heating	RFT IDU LABEL	RFT IDU LABEL	RFT IDU LABEL	RFT IDU LABEL	RFT IDU LABEL
Rated Current (A)	Cooling	RFT IDU LABEL	RFT IDU LABEL	RFT IDU LABEL	RFT IDU LABEL	RFT IDU LABEL
	Heating	RFT IDU LABEL	RFT IDU LABEL	RFT IDU LABEL	RFT IDU LABEL	RFT IDU LABEL
Air Circulation (m ³ Max)		2700	3200	3500	6000	6000
Noise Level (dB (A))		52	56	57	57	55
Piping						
Diameter(Liquid)	Inch	1/4	3/8	3/8	3/8	3/8
Diameter(Gas)	Inch	1/2	5/8	5/8	3/4	3/4
Max Length	m	20	30	30	50	50
Max Height	m	15	15	20	30	30
Refrigerant charge volume	g	1200	1650	2100	3100	3400
Dimensions WxHxD (mm)						
Net Dimensions WxHxD (mm)	Outdoor Unit	800×550×260	900×640×300	950×840×340	950×1386×340	950×1386×340
Net Weight (Kg)	Outdoor Unit	37	54	83	114	114
Packing Dimensions WxHxD (mm)	Outdoor Unit	930×620×360	1050×700×400	1110×980×460	1110×1530×460	1110×1530×460
Gross Weight (Kg)	Outdoor Unit	40	60	91	124	124

2. SPECIFICATIONS

Outdoor Unit:		AUW-18H4SU1	AUW-24H4SZ1	AUW-36H6S1A1	AUW-48H 6SE1	AUW-60H6SP 1
Performance						
Power Supply						
Volt/Phase/Hz		220-240V~/1P/5 0Hz	220-240V~/1P/5 0Hz	380~415V~/3Ph/5 0Hz	380-415V ~/3Ph/50H z	380-415V~/3P h/50Hz
Rated Input (w)	Cooling	RFT IDU LABEL	RFT IDU LABEL	RFT IDU LABEL	RFT IDU LABEL	RFT IDU LABEL
	Heating	RFT IDU LABEL	RFT IDU LABEL	RFT IDU LABEL	RFT IDU LABEL	RFT IDU LABEL
Rated Current (A)	Cooling	RFT IDU LABEL	RFT IDU LABEL	RFT IDU LABEL	RFT IDU LABEL	RFT IDU LABEL
	Heating	RFT IDU LABEL	RFT IDU LABEL	RFT IDU LABEL	RFT IDU LABEL	RFT IDU LABEL
Air Circulation (m ³ Max)		2700	3200	3500	5000	6000
Noise Level (dB (A))		52	56	59	55	58
Piping						
Diameter(Liquid)	Inch	1/4	3/8	3/8	3/8	3/8
Diameter(Gas)	Inch	1/2	5/8	5/8	3/4	3/4
Max Length	m	20	30	30	50	50
Max Height	m	15	15	20	30	30
Refrigerant charge volume	g	1200	1650	2300	2400	3100
Dimensions WxHxD (mm)						
Net Dimensions WxHxD (mm)	Outdoor Unit	800×550×260	900×640×300	950×840×340	950×1050 ×340	950×1386×340
Net Weight (Kg)	Outdoor Unit	37	54	68	96	106
Packing Dimensions WxHxD (mm)	Outdoor Unit	930×620×360	1050×700×400	1110×980×460	1110×120 0×460	1110×1530×46 0
Gross Weight (Kg)	Outdoor Unit	40	60	76	103	116

3. OUTLINES AND DIMENSIONS

3.1 INDOOR UNIT

Duct Type

18K

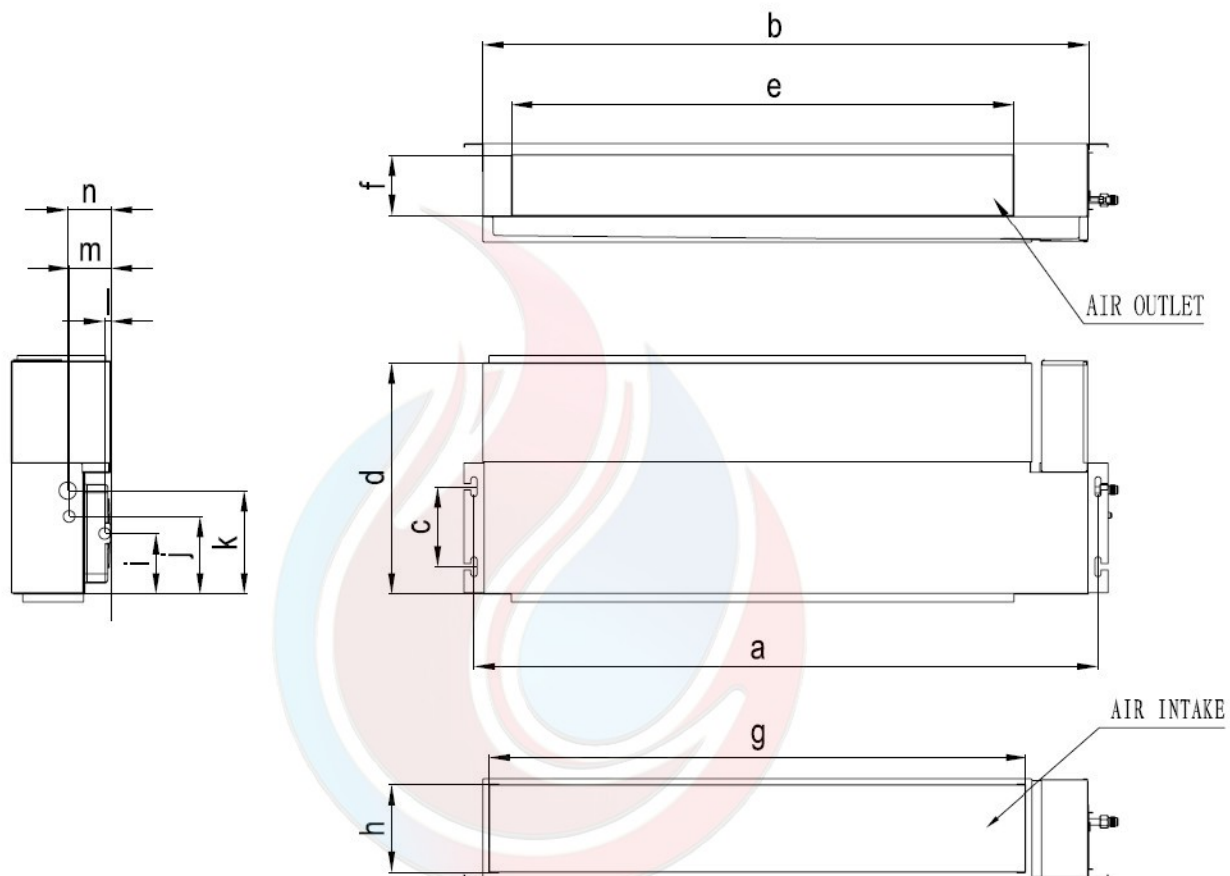

a	b	c	d	e	f	g	h	i	j	k	l	m	n
937	900	154	447	701	120	769	170	117	150	199	13	81	84

3. OUTLINES AND DIMENSIONS

24K/36K/48K/60K

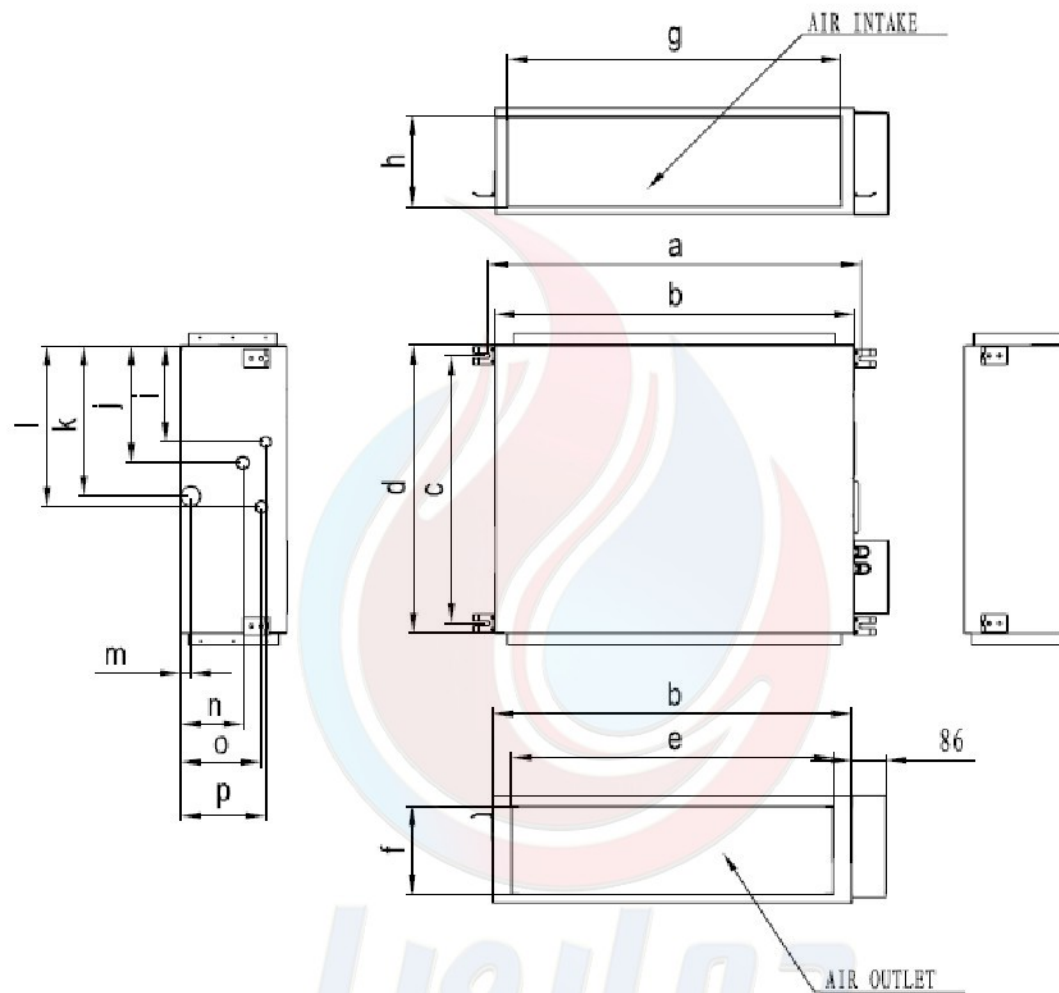

	a	b	c	d	e	f	g	h	i	j	k	l	m	n	o	p	q
24k	934	900	669	720	805	222	835	228	242	294	378	405	25	156	202	214	270
36K																	
/48k	1334	1295	740	796	1205	222	1235	308	237	312	375	405	25	204	203	242	350
/60k																	

3. OUTLINES AND DIMENSIONS

Cassette Type

18k

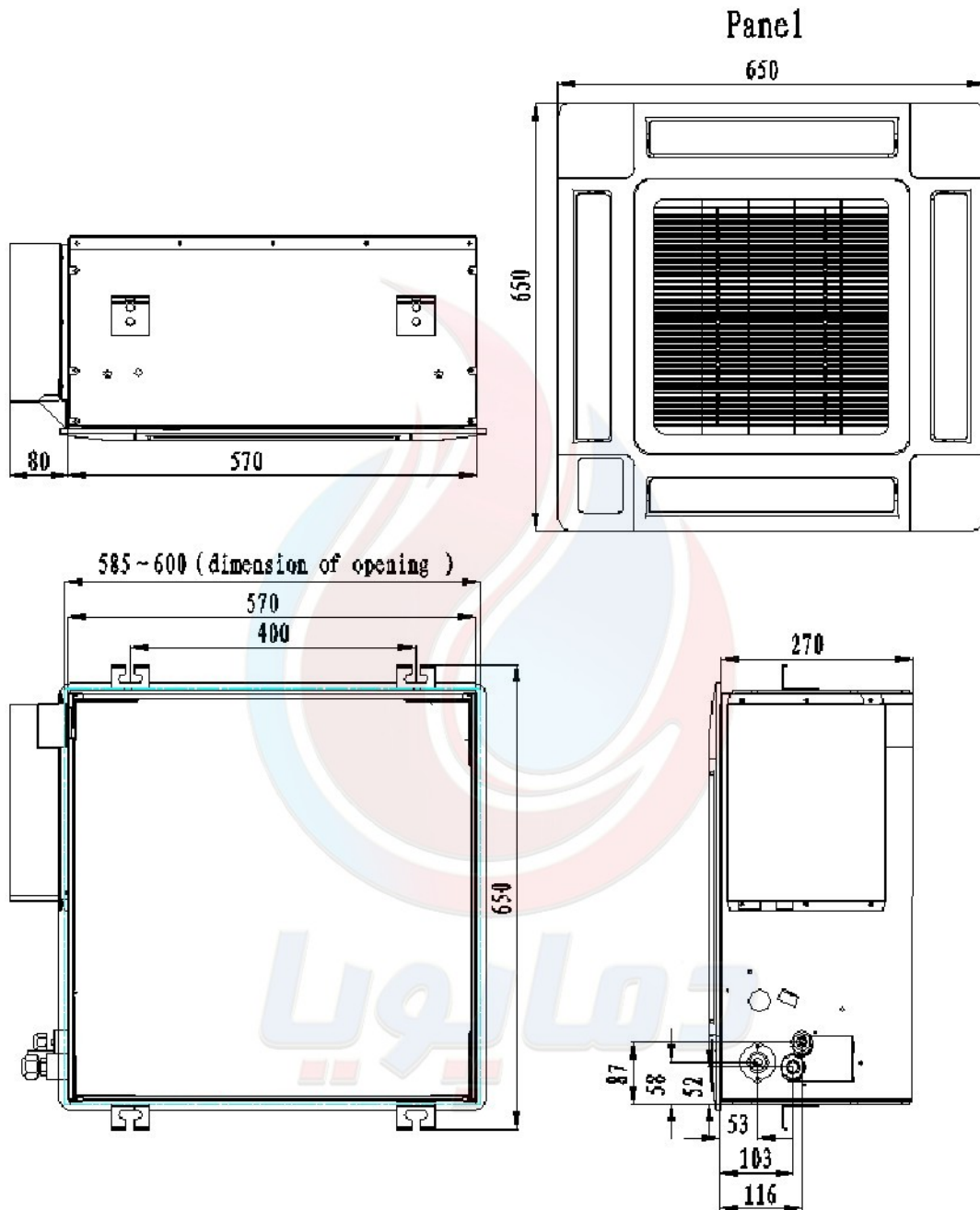

3. OUTLINES AND DIMENSIONS

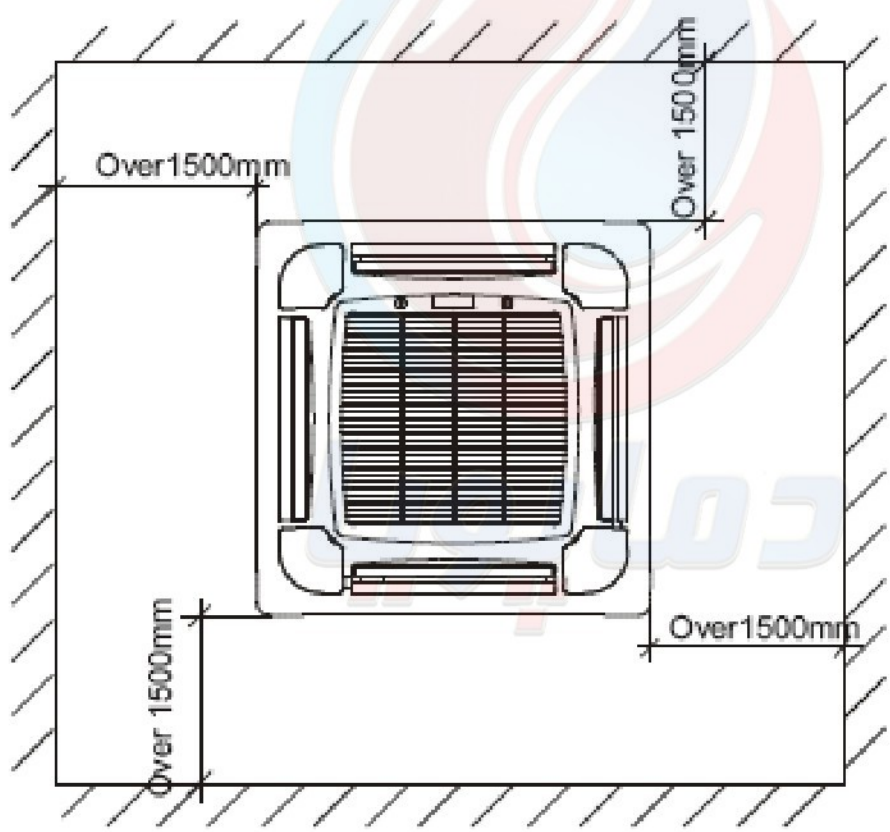
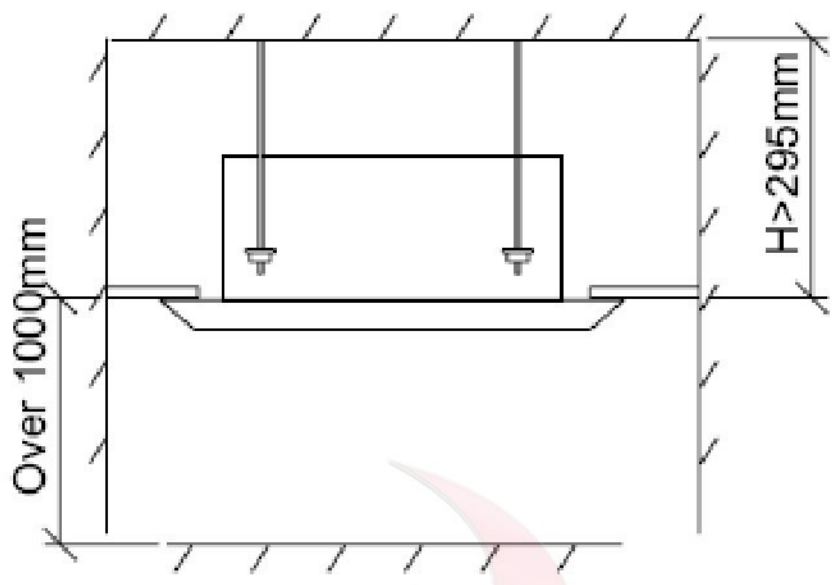

3. OUTLINES AND DIMENSIONS

24K,36K,48K,60K

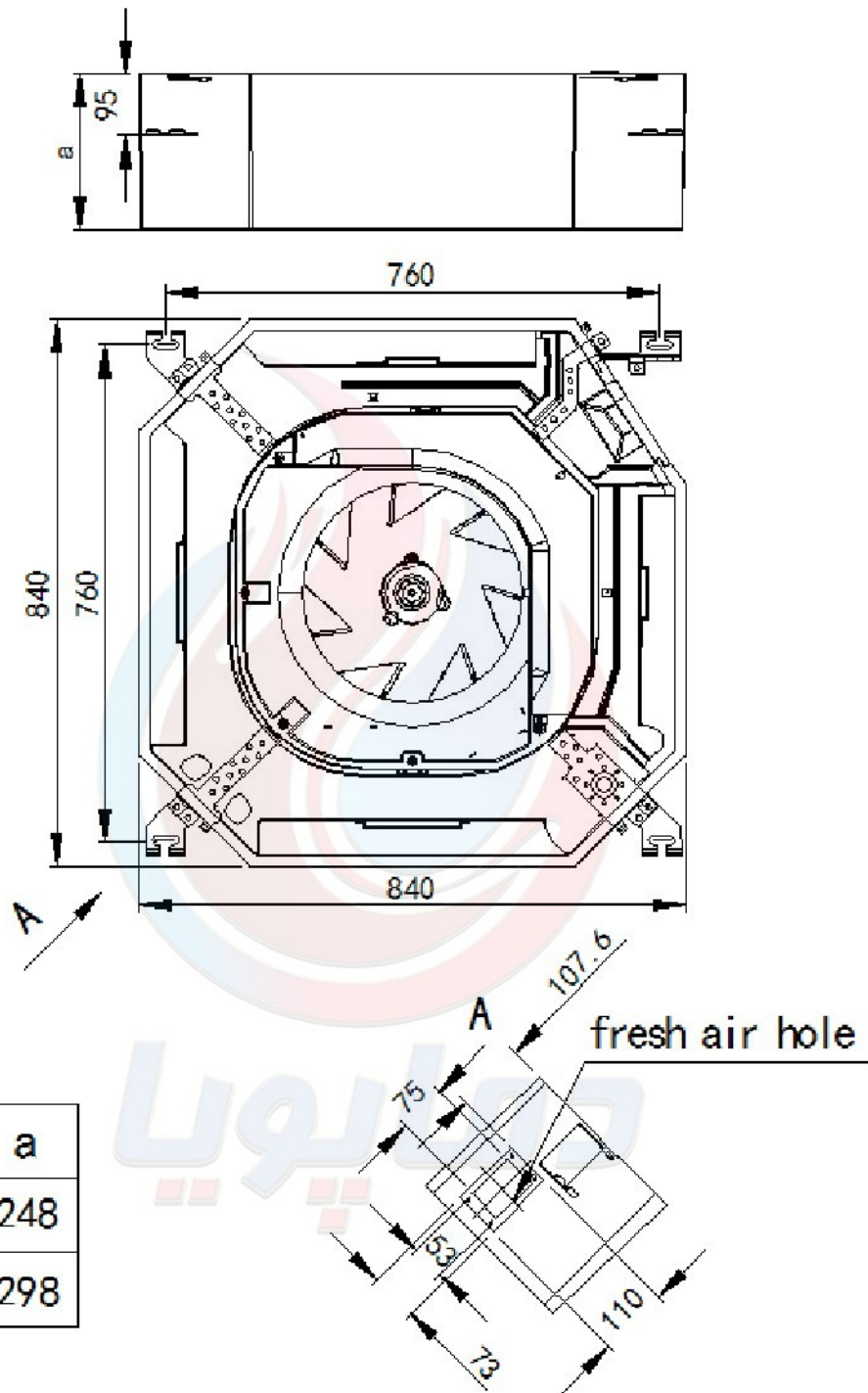

3. OUTLINES AND DIMENSIONS

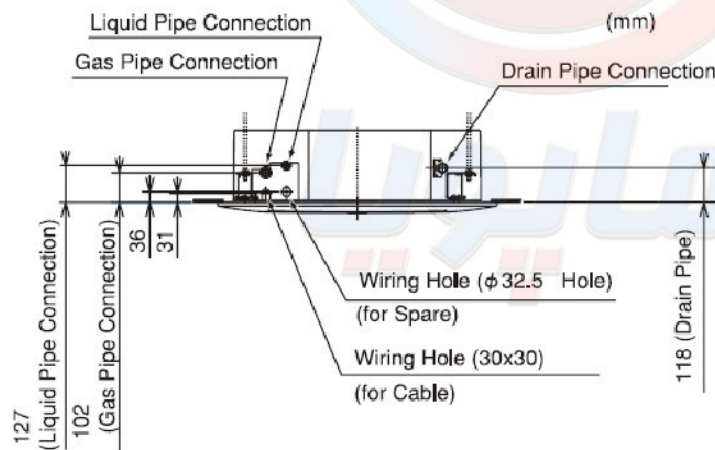
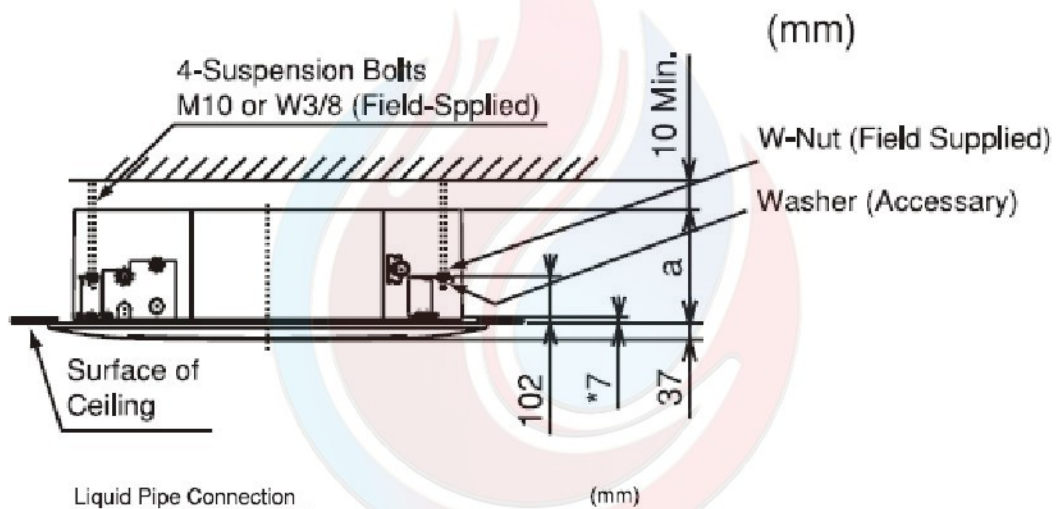
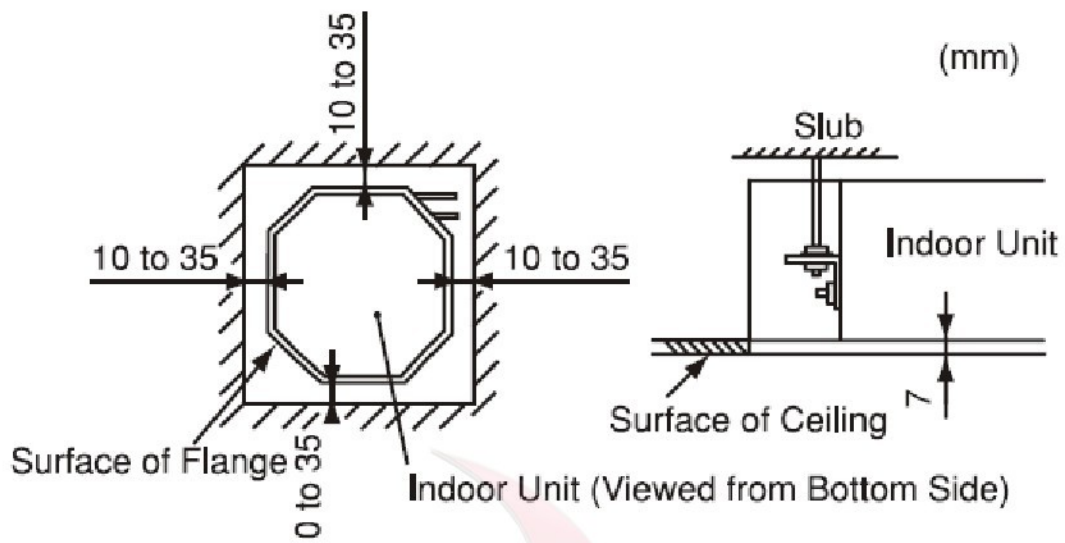

3. OUTLINES AND DIMENSIONS

Ceiling&Floor Type

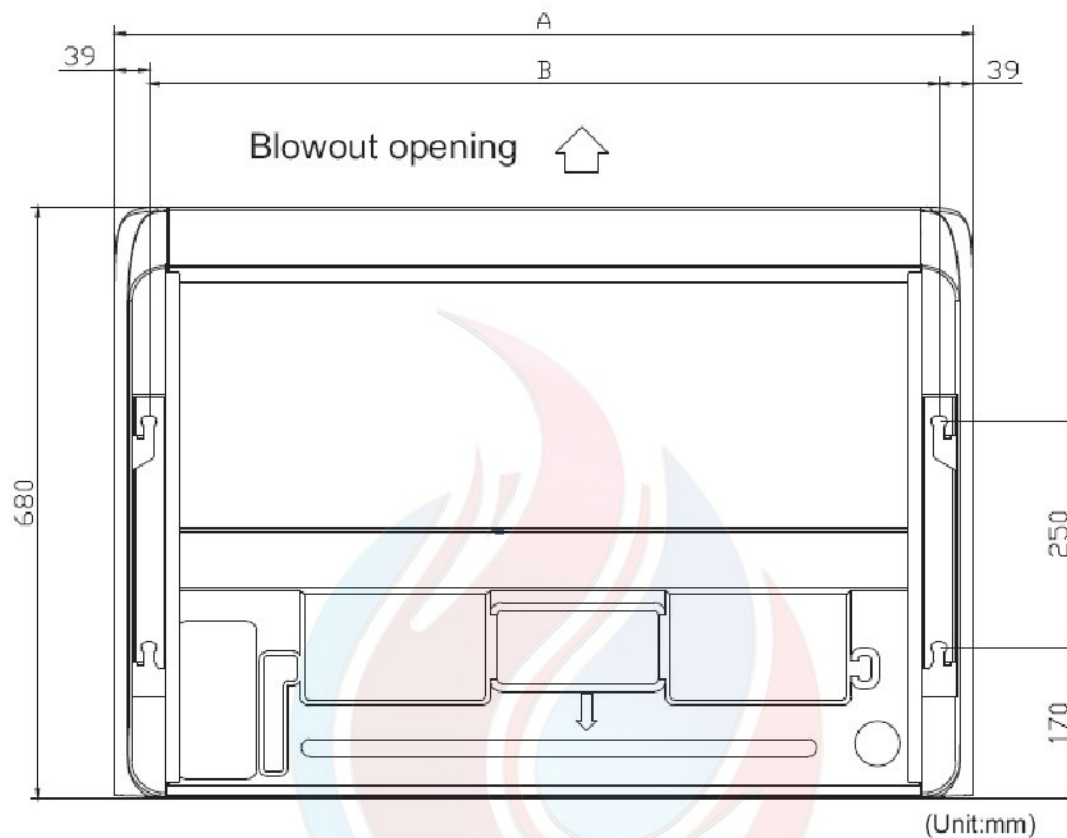

Capacity(Btu/h)	A	B
18K, 24K	990	912
36K	1285	1207
48K, 60K	1580	1502

3. OUTLINES AND DIMENSIONS

3-2.OUTDOOR

18K

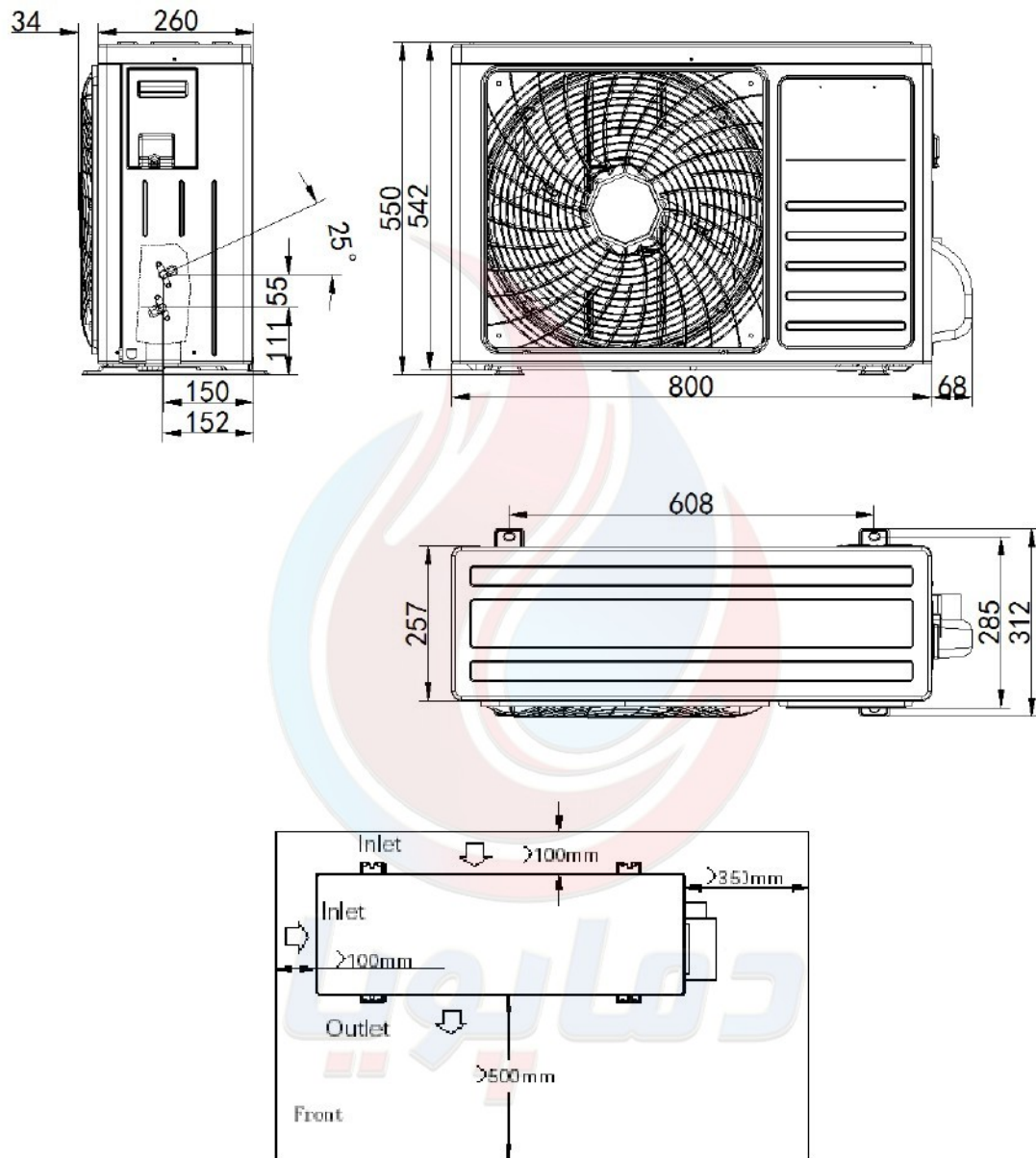

3. OUTLINES AND DIMENSIONS

24K

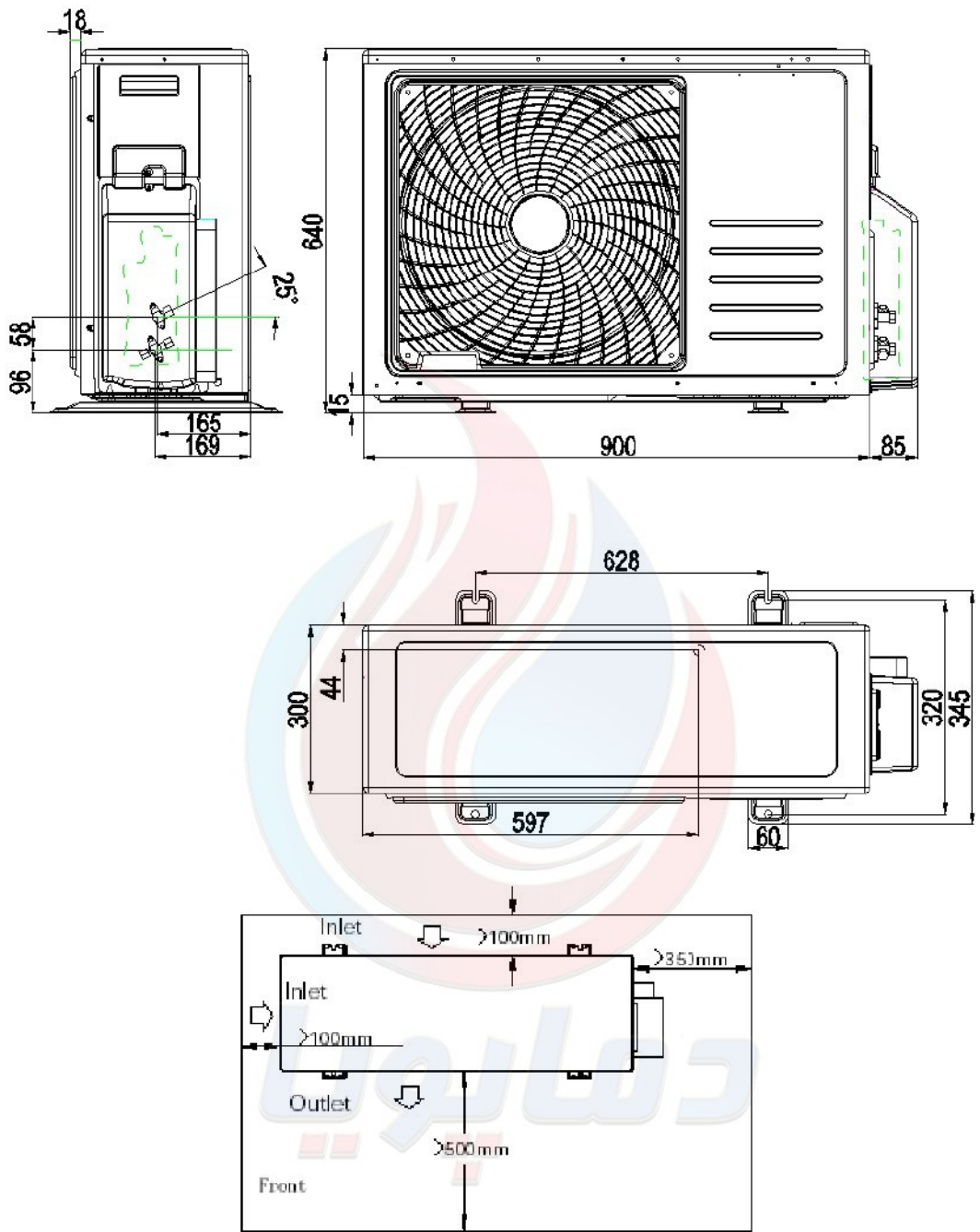

3. OUTLINES AND DIMENSIONS

36K

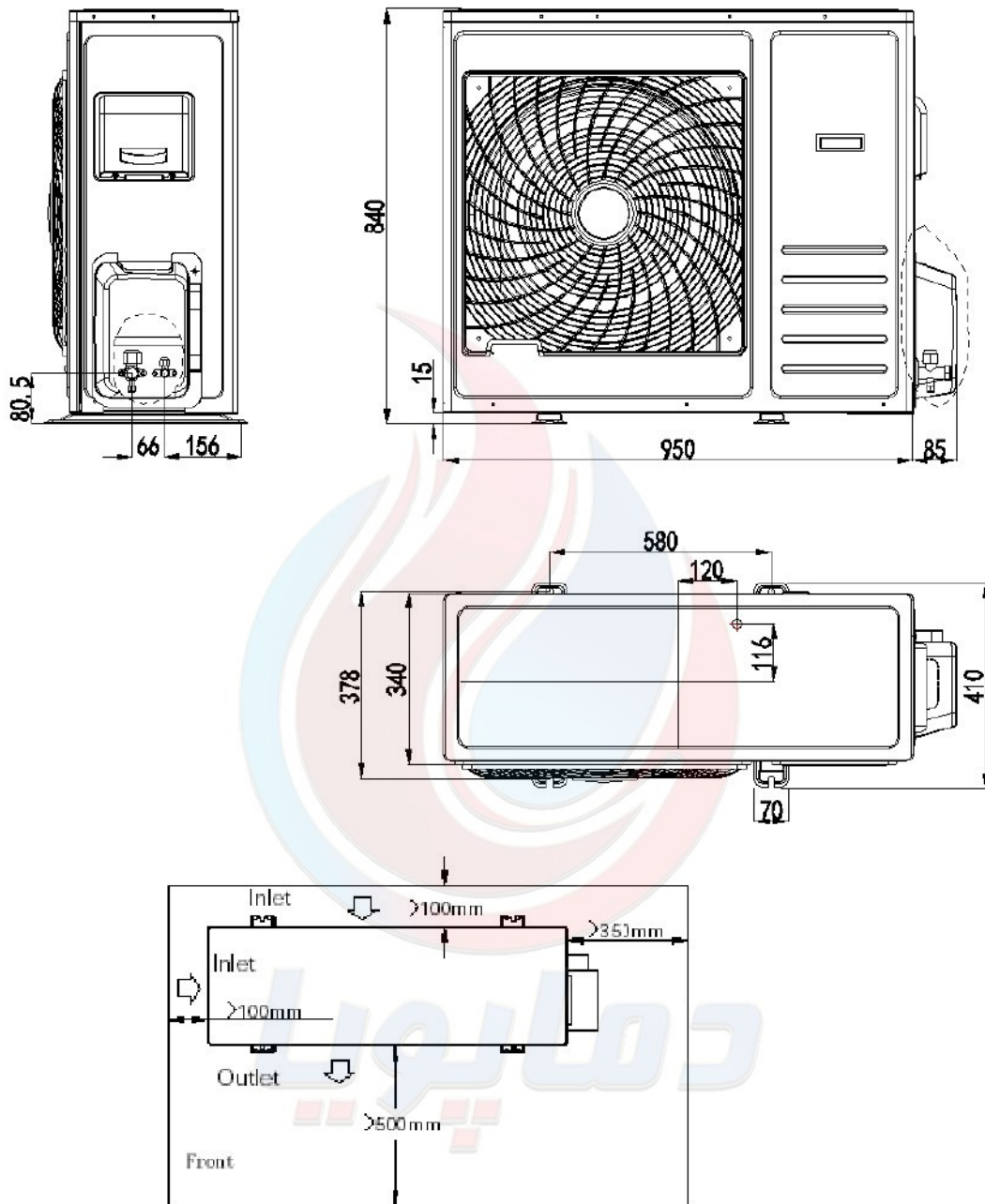

3. OUTLINES AND DIMENSIONS

48K

(Low Ambient Temperature Type)

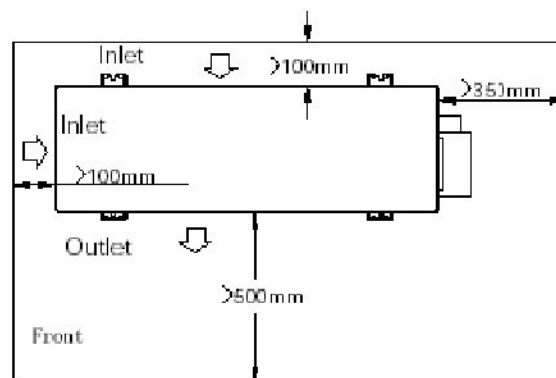
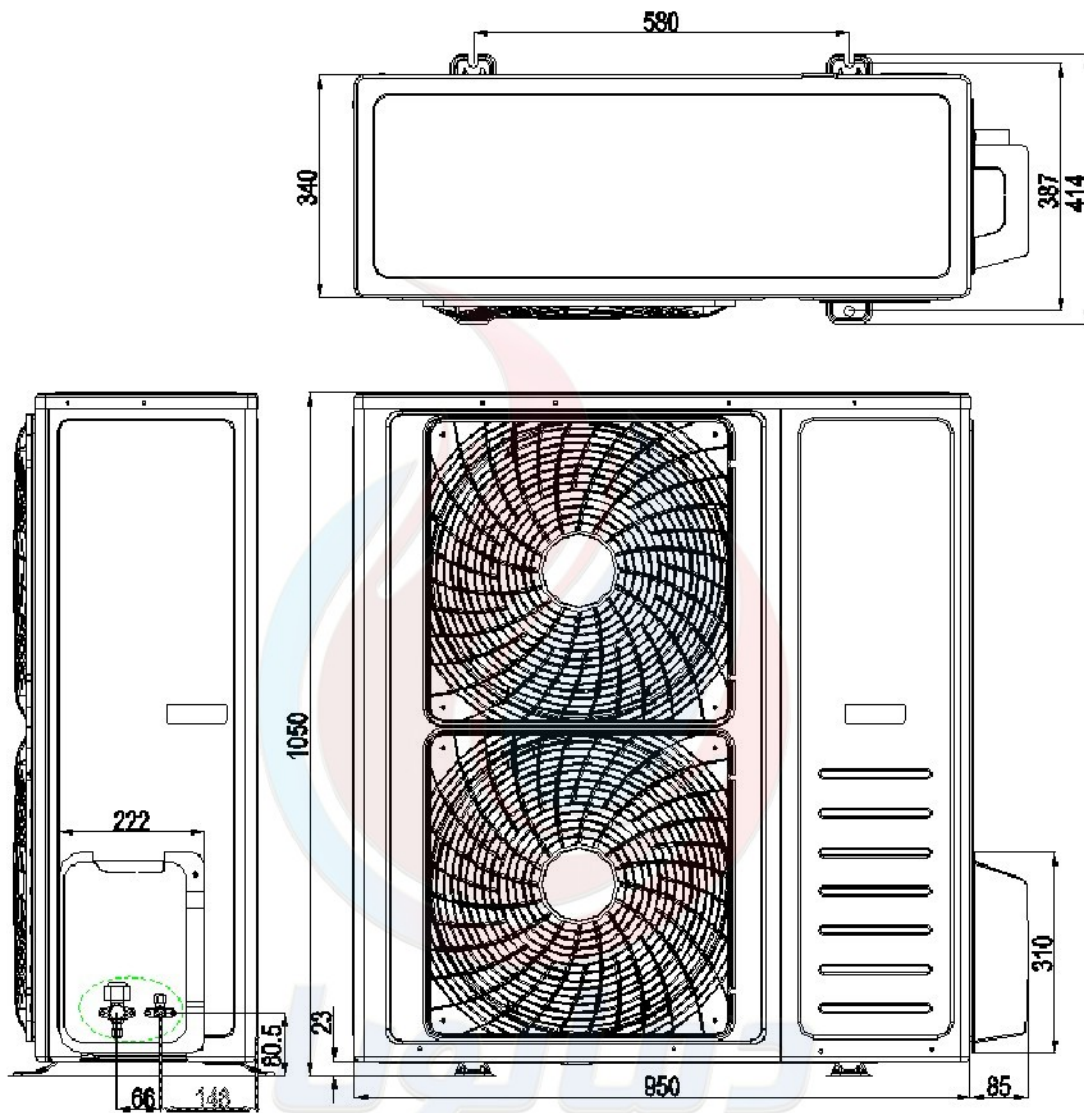

3. OUTLINES AND DIMENSIONS

60K

48K(Ordinary Type)

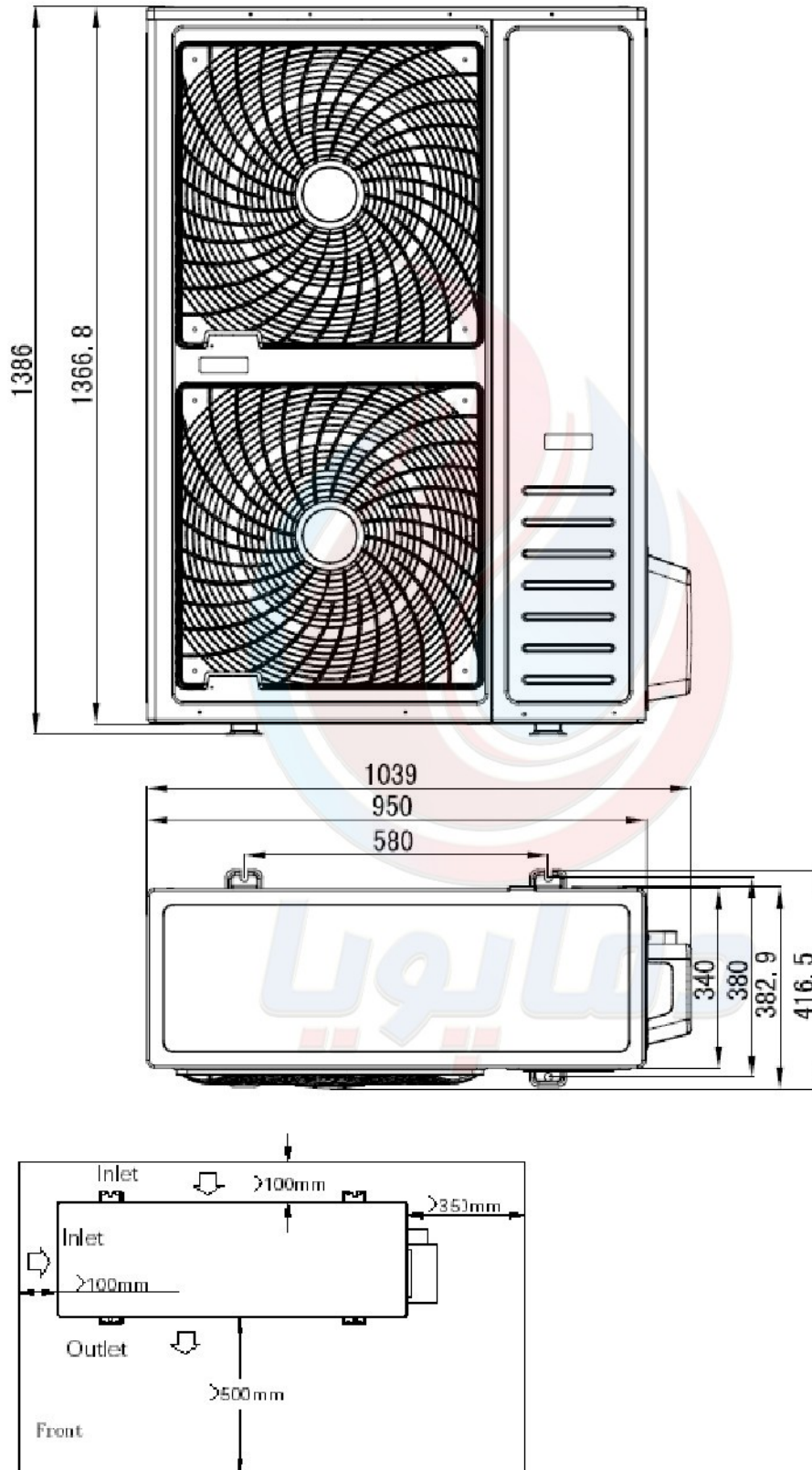

4.Piping Diagrams& Data

4.1 Piping Diagrams

18K

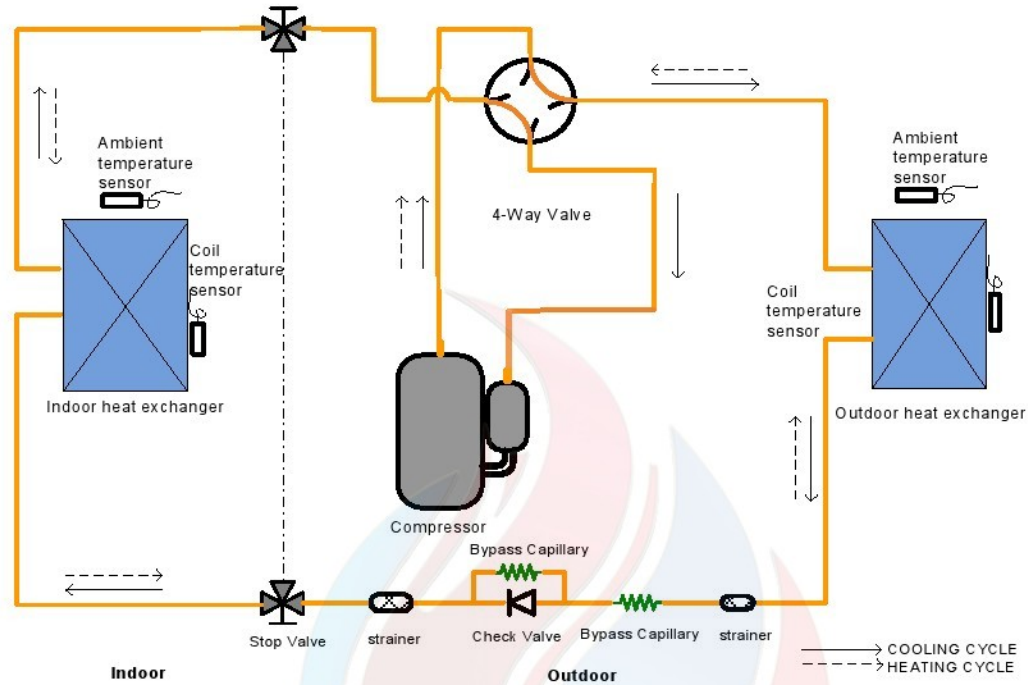

24K

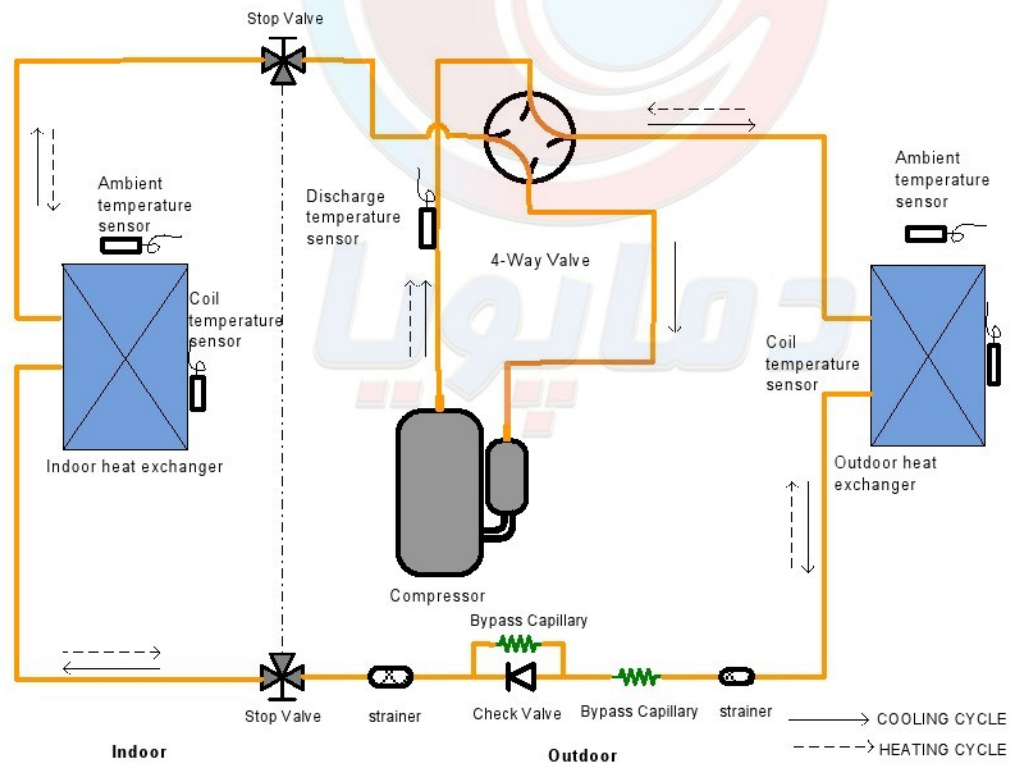

4. DIAGRAM&DATA

36K

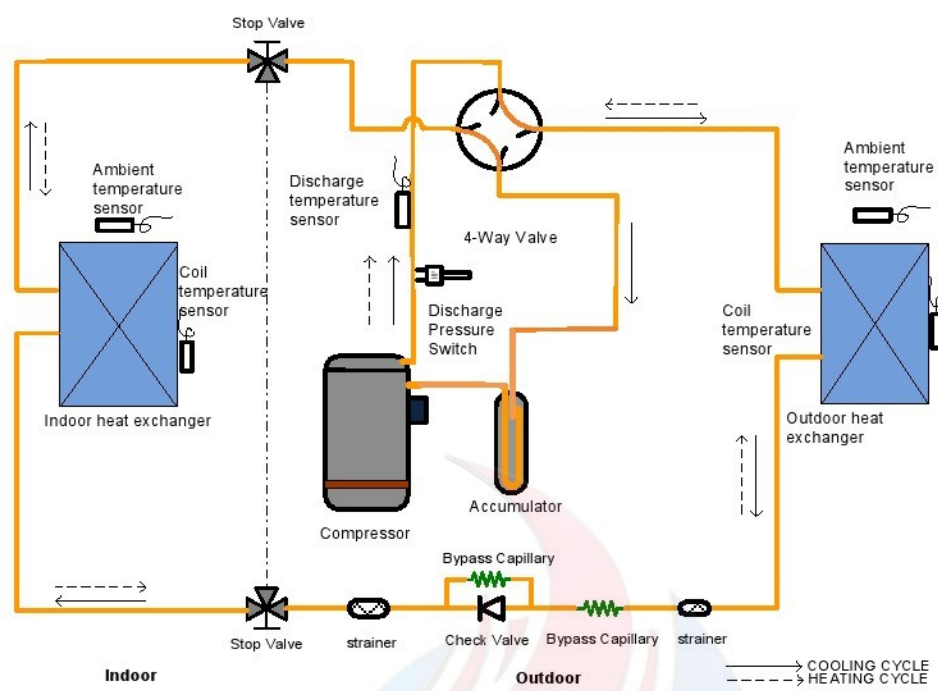

48K(Low Ambient Temperature Type)

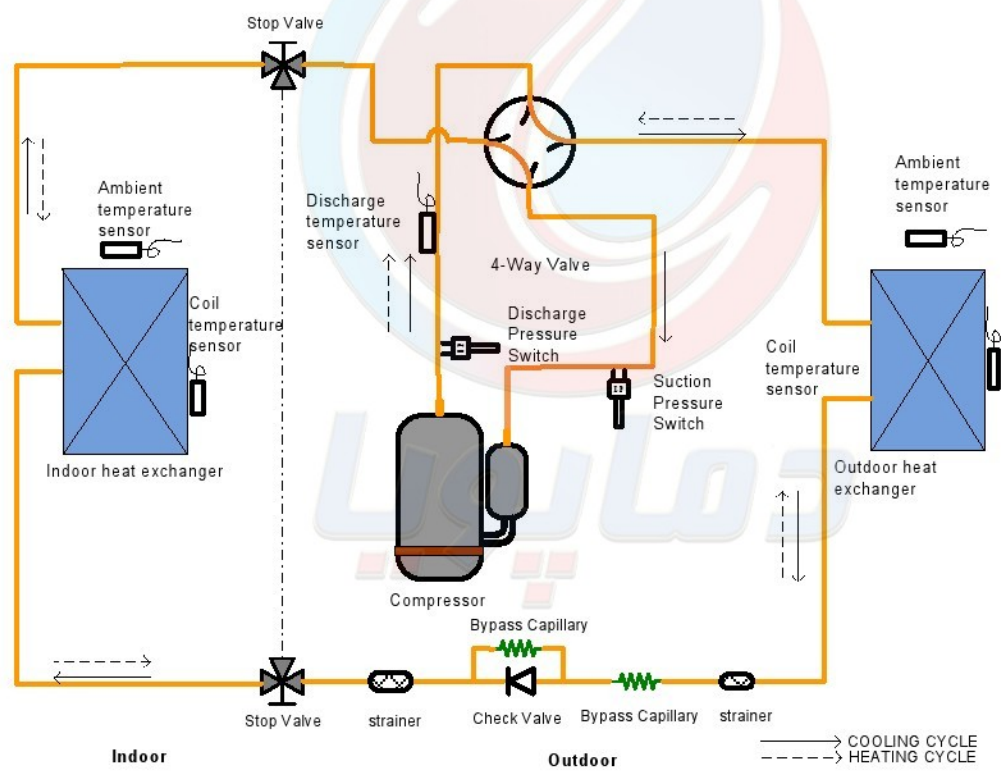

4. DIAGRAM&DATA

60k
(Low Ambient Temperature Type)

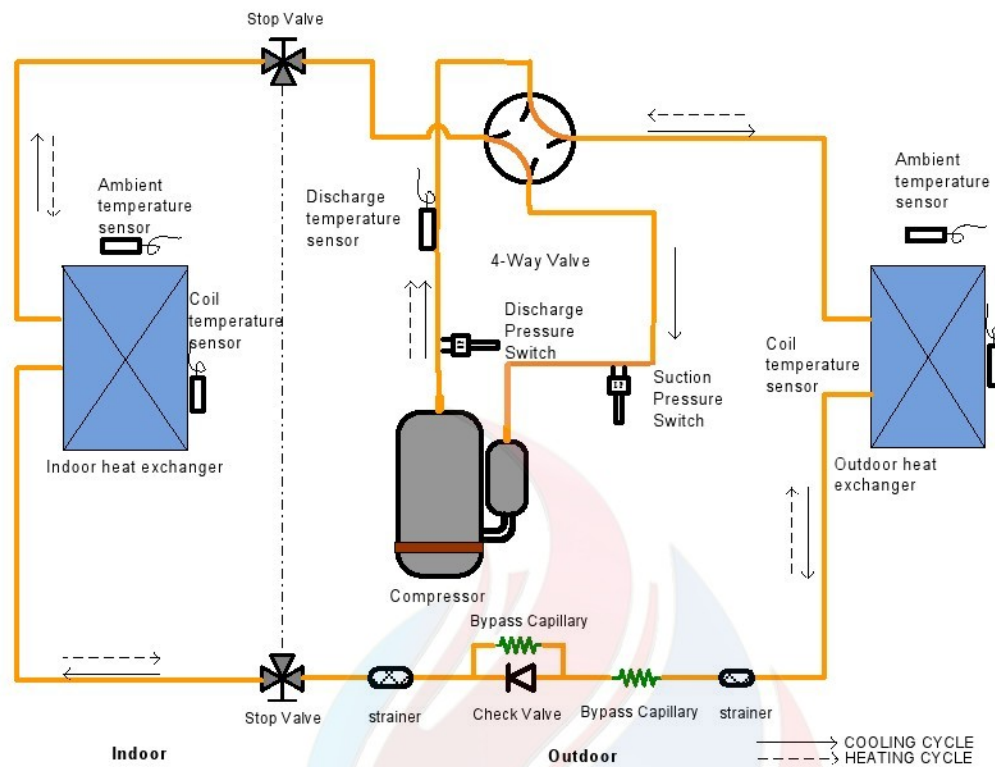

48K、60k(Ordinary Temperature Type)

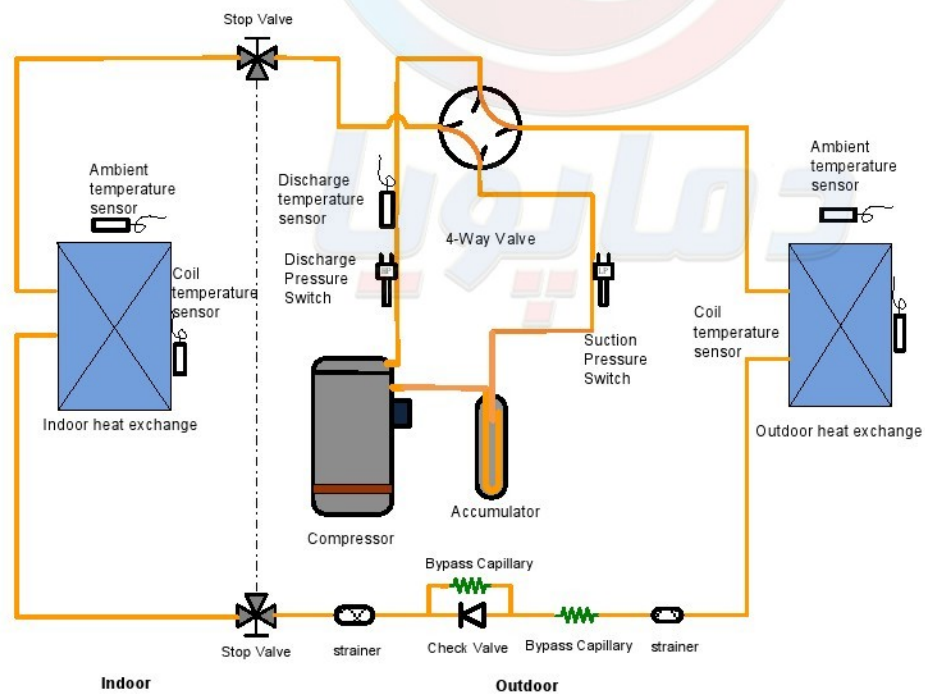

4. DIAGRAM&DATA

4.2MAX. Refrigerant pipe length and height difference:

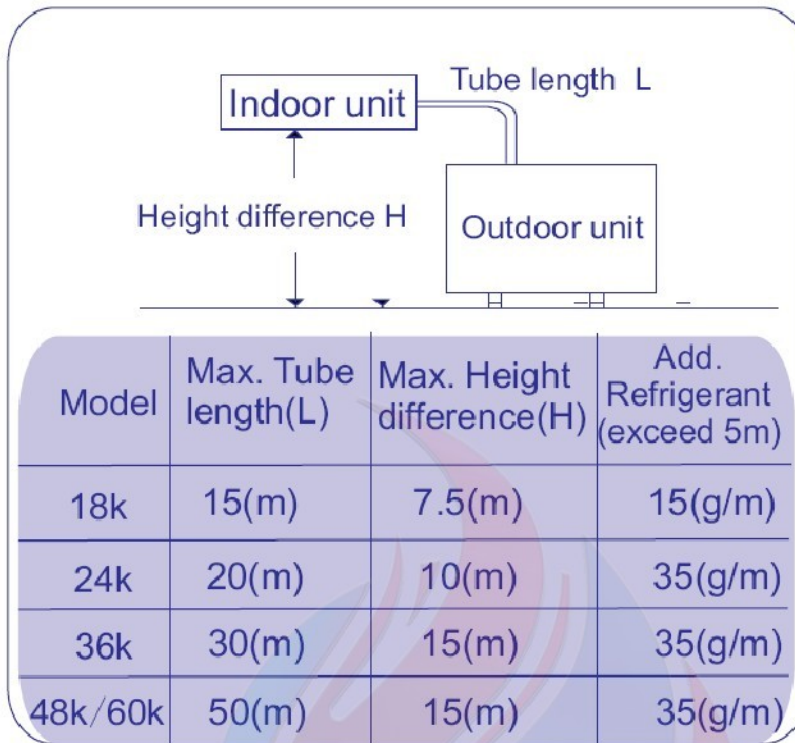

*Do your best to reduce the pipe length. Long pipe may cause capacity of the indoor unit incline.

Outdoor unit precharged		Total refrigerant pipe length	
		0m~5m	Exceed 5m
AUW-18H4SU	1200g	0g	$Xg = 15g / m \times (\text{Total pipe length}(m) - 5)$ $Xg = 35g / m \times (\text{Total pipe length}(m) - 5)$
AUW-24H4SZ	1650g	0g	
AUW-36H6SA	2300g	0g	
AUW-48H6SP	3100g	0g	
AUW-60H6SP	3300g	0g	

Outdoor unit precharged		Total refrigerant pipe length	
		0m~5m	Exceed 5m
AUW-18H4SU1	1200g	0g	$Xg = 15g / m \times (\text{Total pipe length}(m) - 5)$ $Xg = 35g / m \times (\text{Total pipe length}(m) - 5)$
AUW-24H4SZ1	1650g	0g	
AUD-36H6SA1	2300g	0g	
AUD-36H6S1A1	2300g	0g	
AUW-48H6SE1	2400g	0g	
AUW-60H6SP1	3100g	0g	

4. DIAGRAM&DATA

4.3ELECTRIC Diagrams

18K

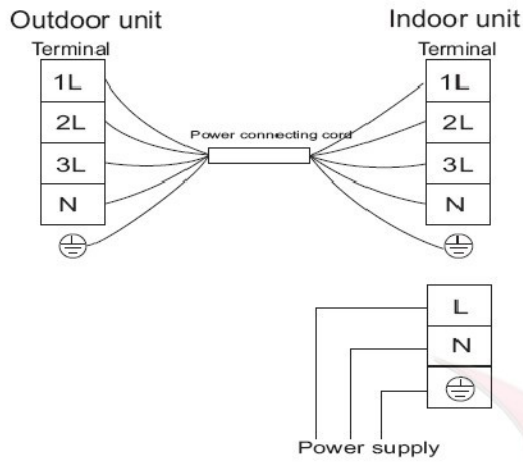

24K

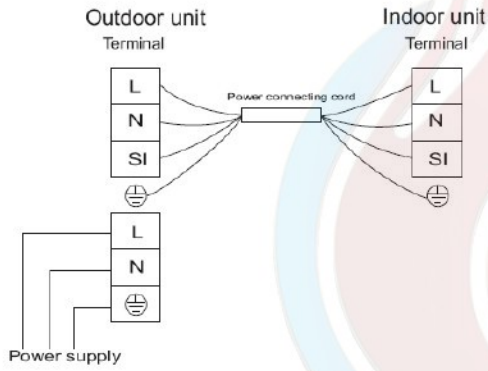

36K/48K/60K

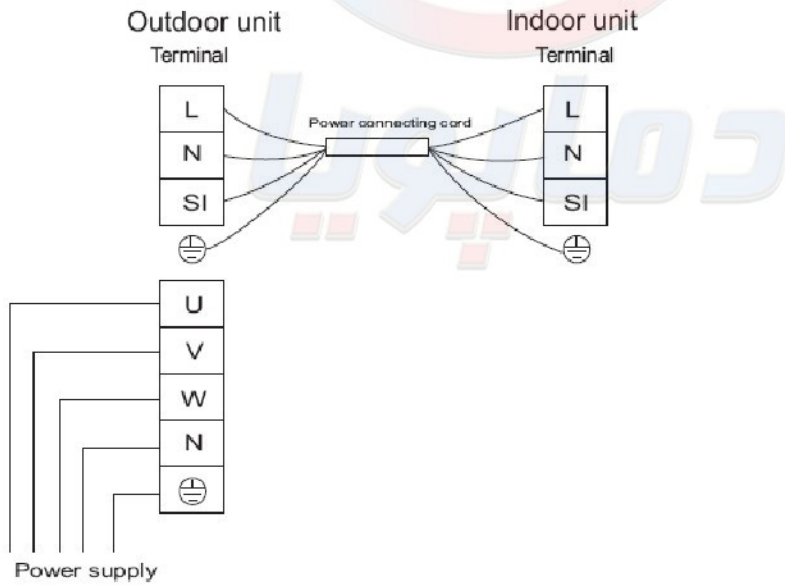

4. DIAGRAM&DATA

Recommend Wire Size

Model Capacity (Btu/h)	POWER SUPPLY	Power Source Cable Size (mm ²)	Transmitting Cable Size (mm ²)
18K	220-240V ~,50Hz	3×1.5	5×1.5
24K	220-240V ~,50Hz	3×2.5	4×1.5
36K	380-415V ~,3N~,50Hz	5×1.5	4×1.5
48K/60K	380-415V ~,3N~,50Hz	5×2.5	4×1.5

- Use an ELB (Electric Leakage Breaker). If not used, it will cause an electric shock or a fire.

- Do not operate the system until all the check points have been cleared.

(A) Check to ensure that the insulation resistance is more than 1 megohm, by measuring the

resistance between ground and the terminal of the electrical parts. If not, do not operate the system until the electrical leakage is found and repaired.

(B) Check to ensure that the stop valves of the outdoor unit are fully opened and then start the system.

- Pay attention to the following items while the system is running.

(A) Do not touch any of the parts by hand at the discharge gas side, since the compressor chamber and the pipes at the discharge side are heated higher than 90°C.

(B) DO NOT PUSH THE BUTTON OF THE MAGNETIC SWITCH(ES). It will cause a serious Accident.

NOTES:

1) Follow local codes and regulations when selecting field wires.

2) The wire sizes marked in the table are selected at the maxim current of the unit according to the European Standard ,En60 335-1. Use the wires which are not lighter than the ordinary tough rubber sheathed flexible cord (code designation H05RN-F) or ordinary polychloroprene sheathed flexible

4. DIAGRAM&DATA

cord (code designation H05RN-F) .

3) Use a shielded cable for the transmitting circuit and connect it to ground .

4) In the case that power cables are connected in series, add each unit maximum current and select wires below.

Selection According to EN60 335-1

Current i (A)	Wire Size (mm ²)
$i \leq 6$	0.75
$6 < i \leq 10$	1
$10 < i \leq 16$	1.5
$16 < i \leq 25$	2.5
$25 < i \leq 32$	4
$32 < i \leq 40$	6
$40 < i \leq 63$	10
$63 < i$	*3

* in the case that current exceeds 63A, do not connect cables in series.

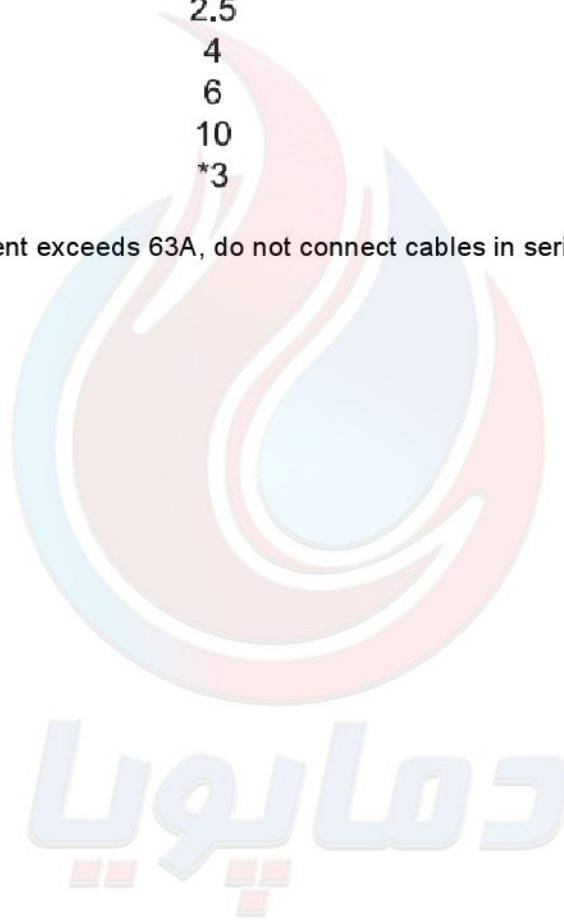

4-4 Air flow and ESP Chart Diagrams(for duct type)

18K

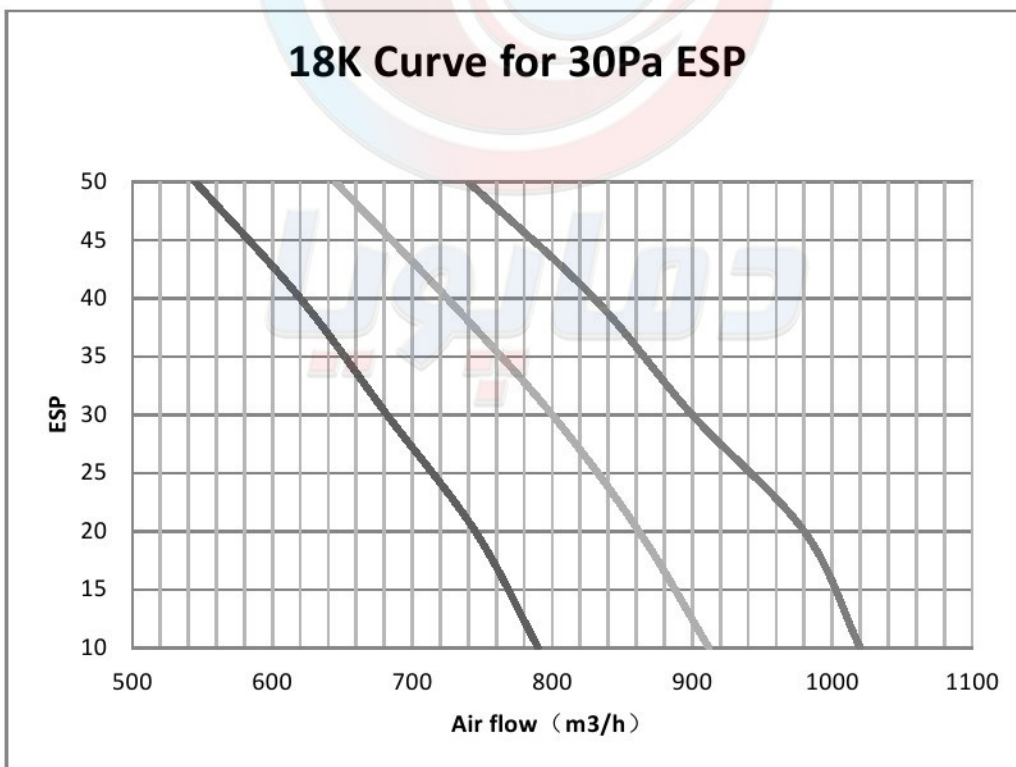
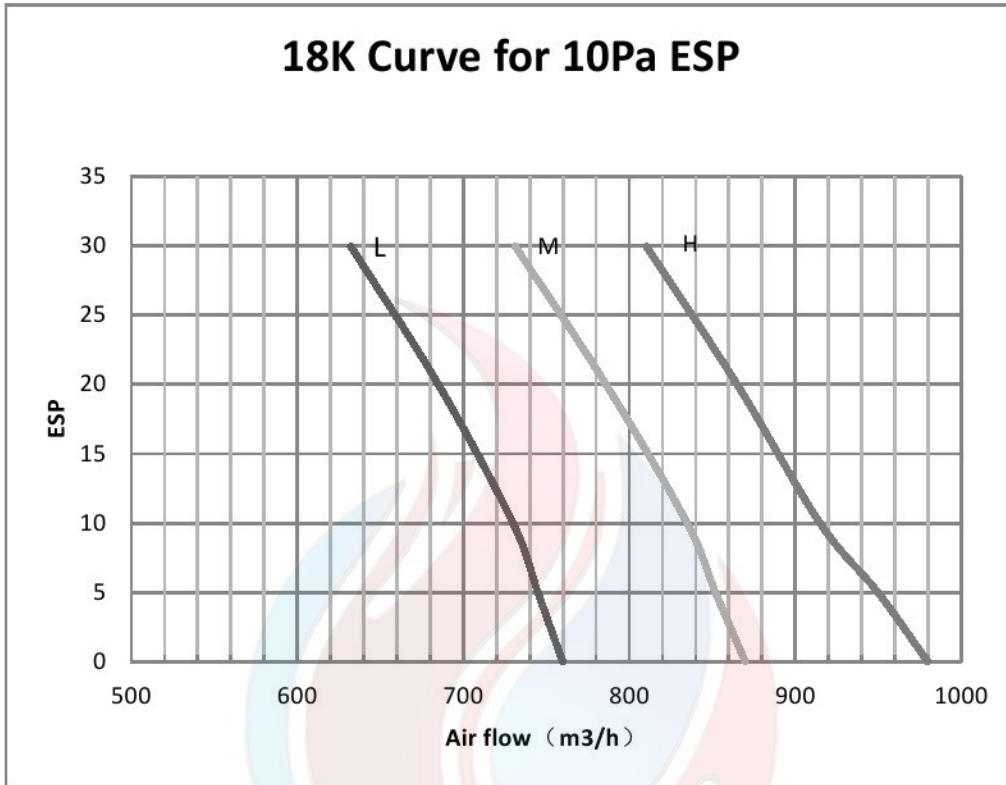

24K

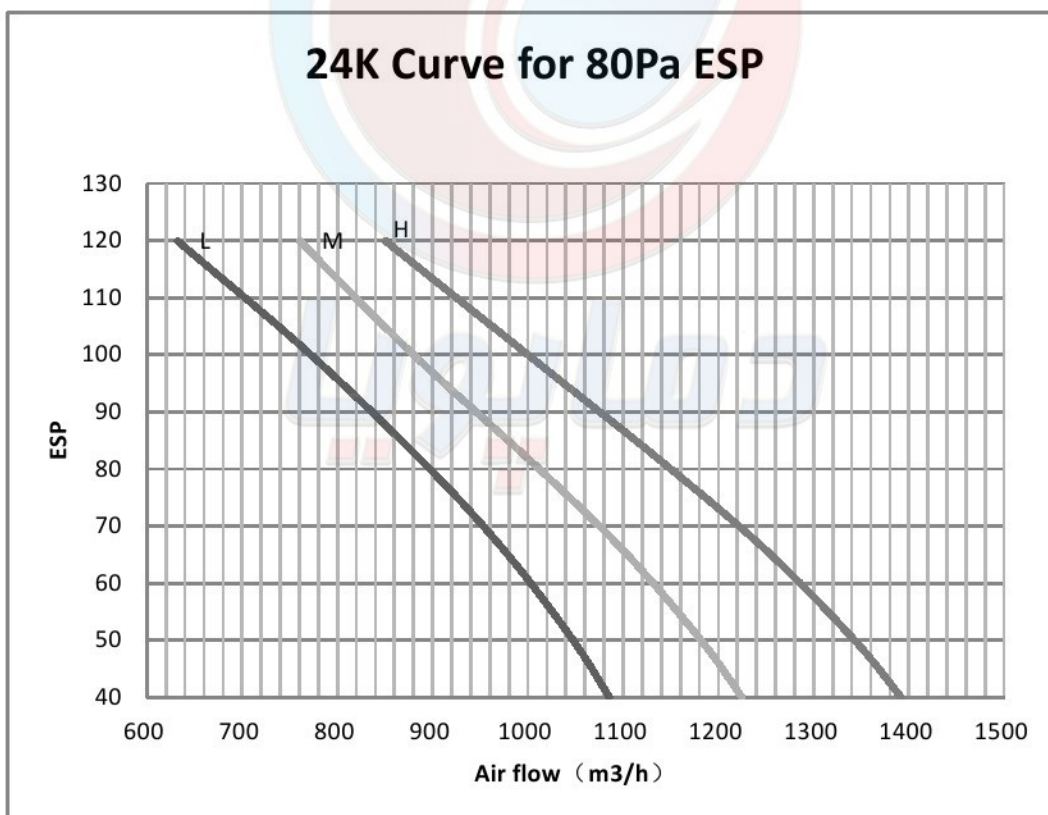
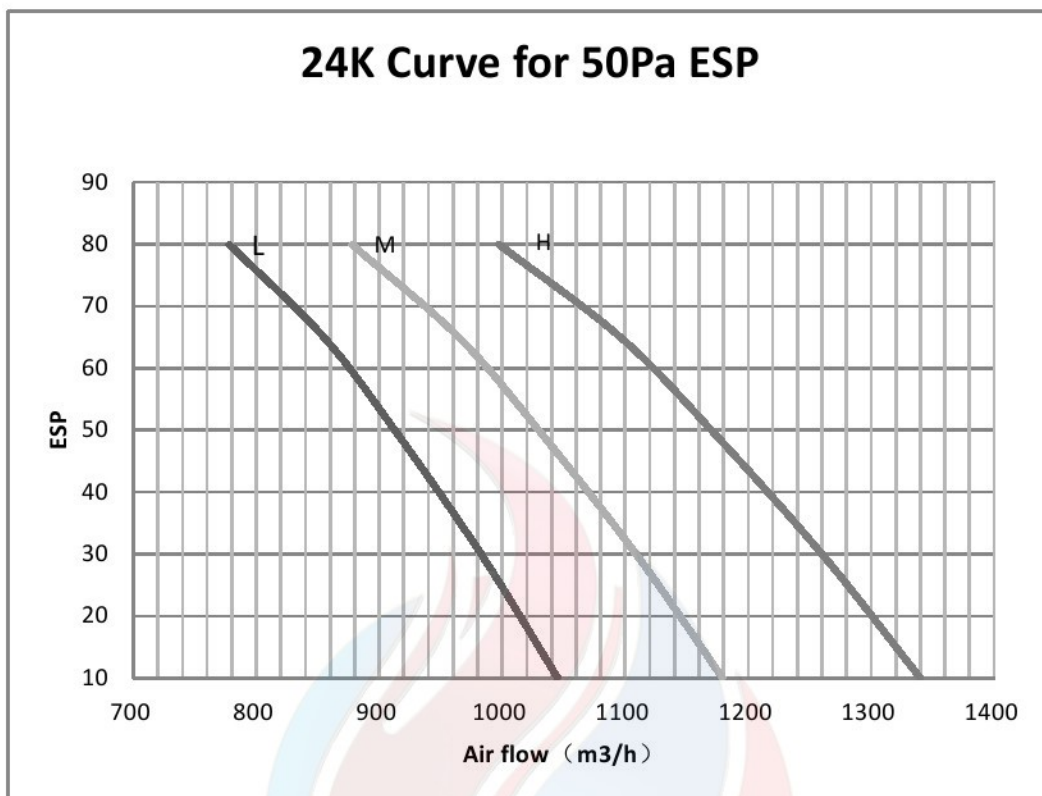

36K

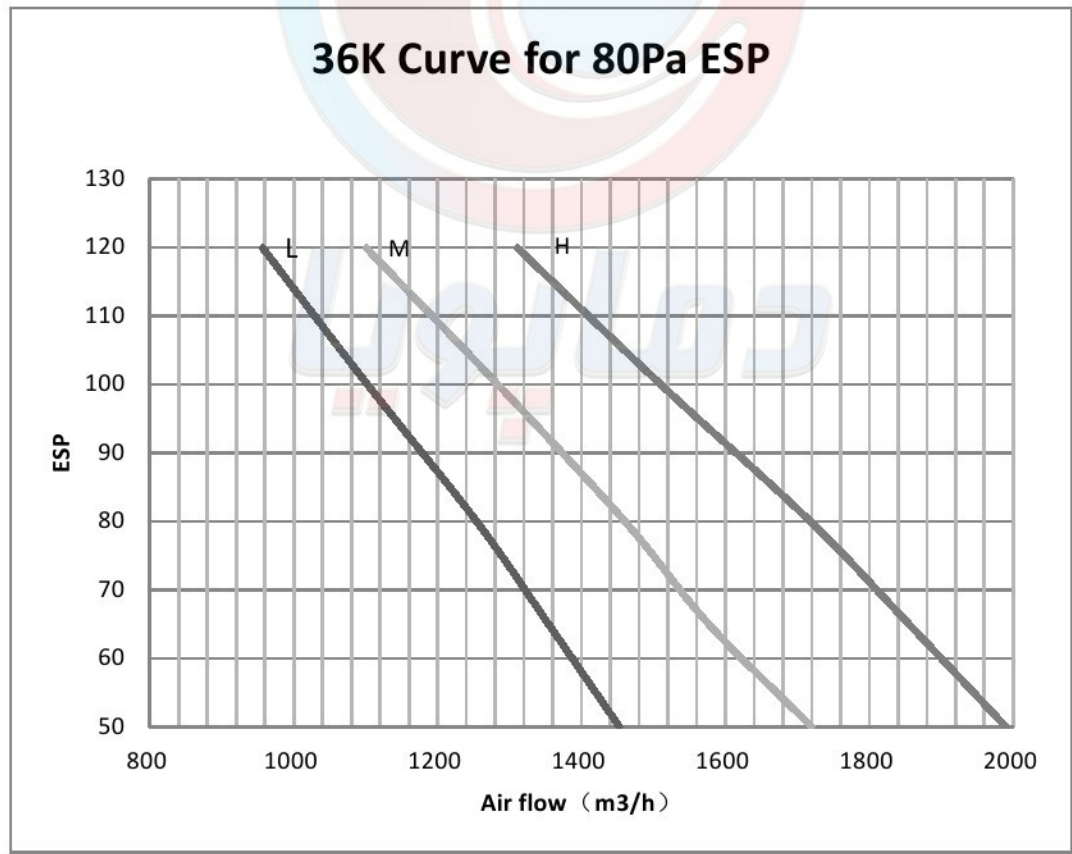
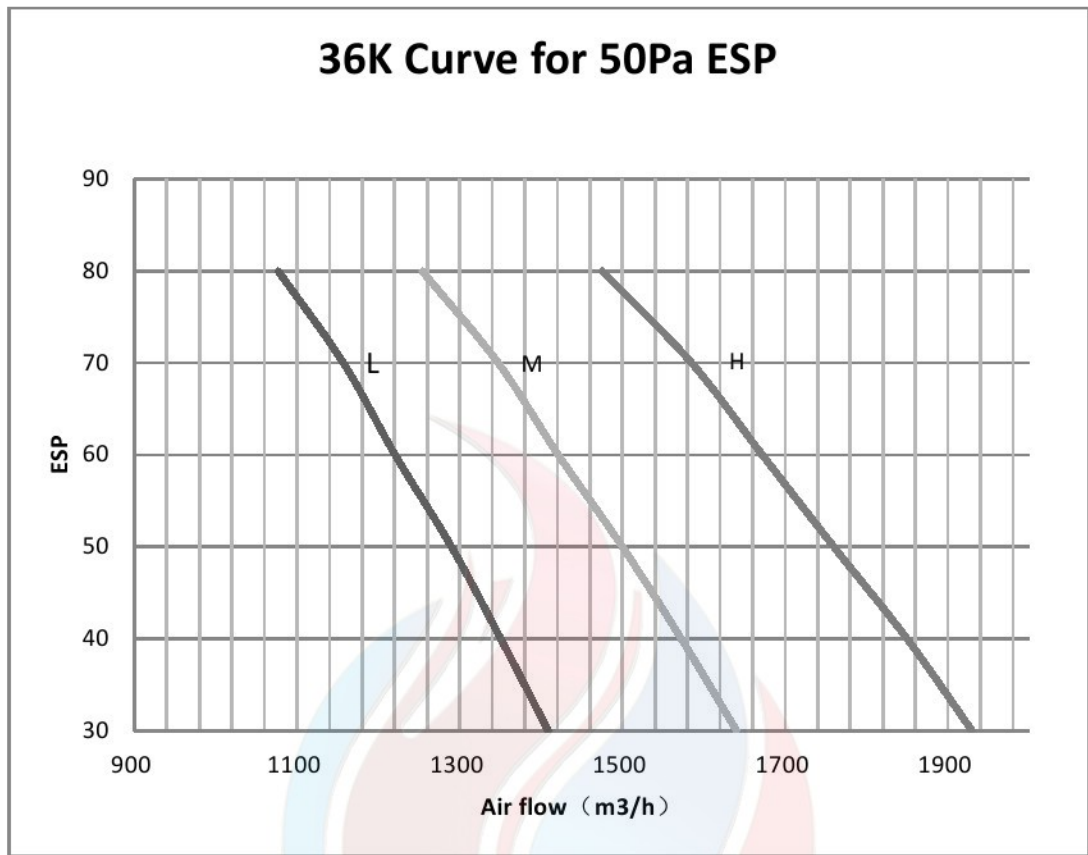

48K

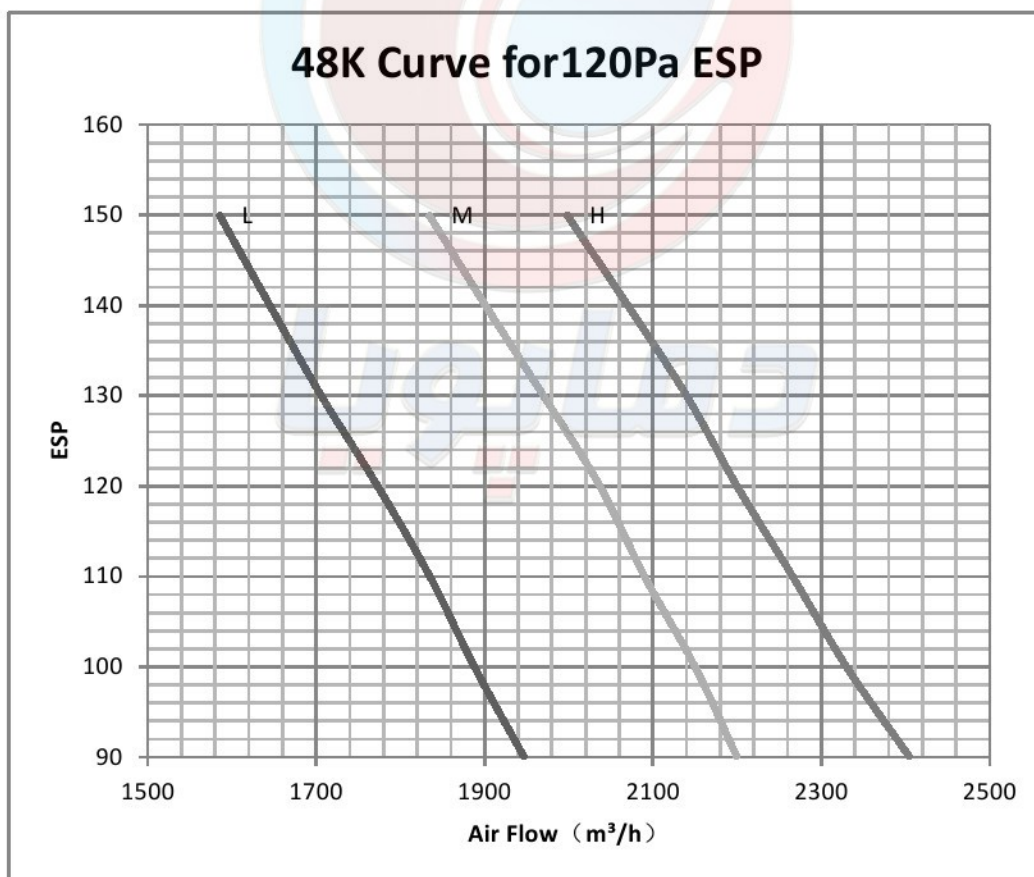
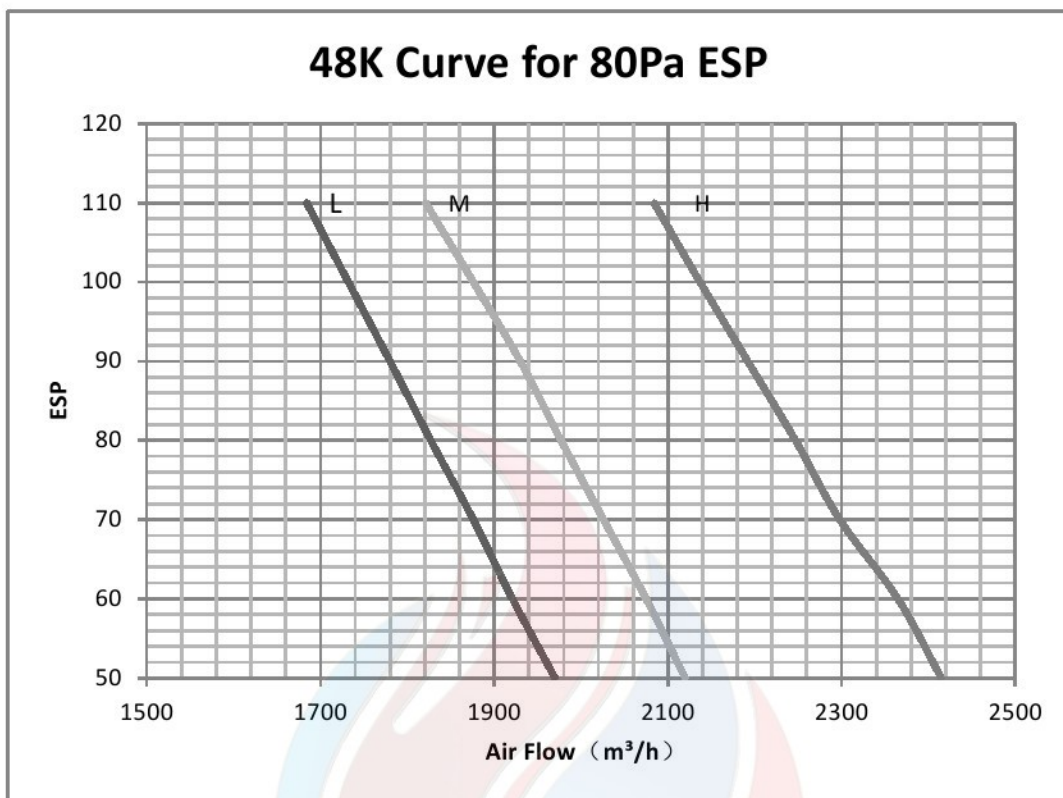

60K

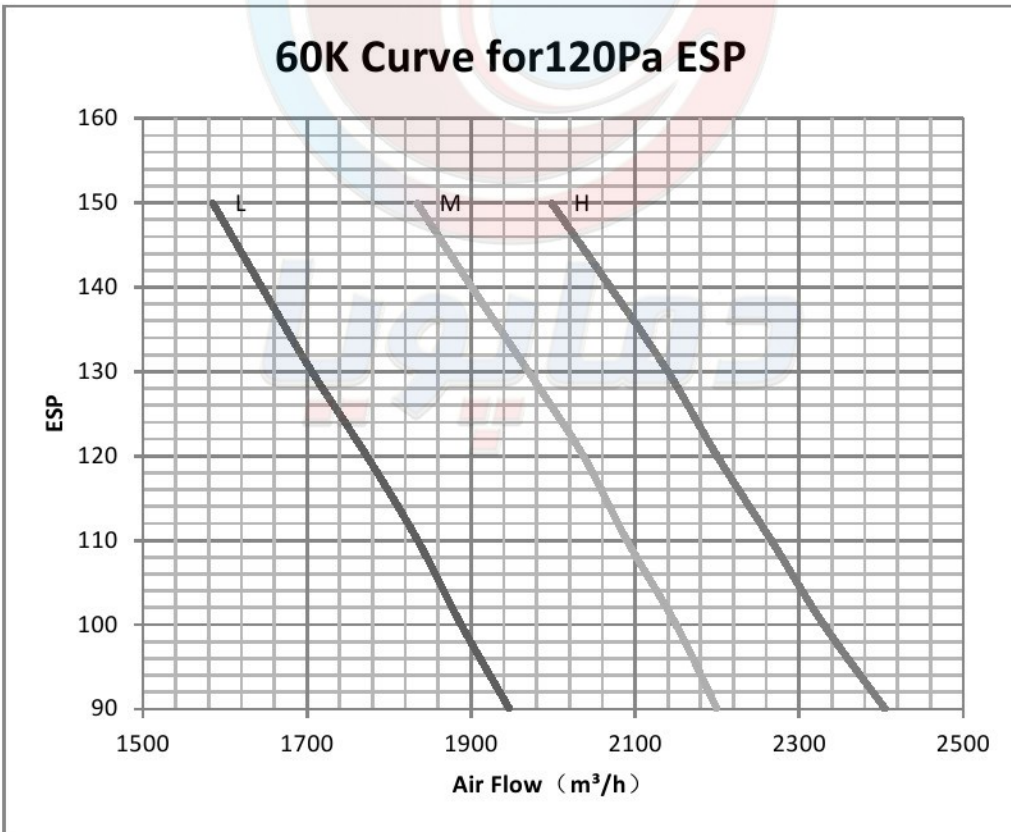
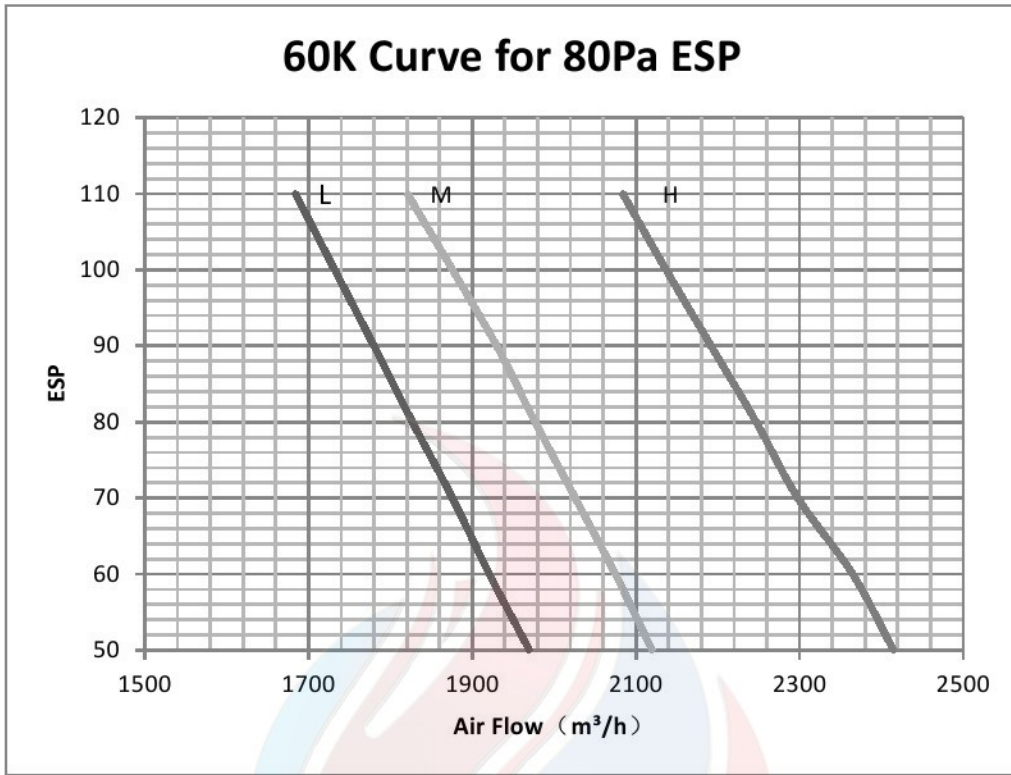

4. DIAGRAM&DATA

4-5 Performance curve

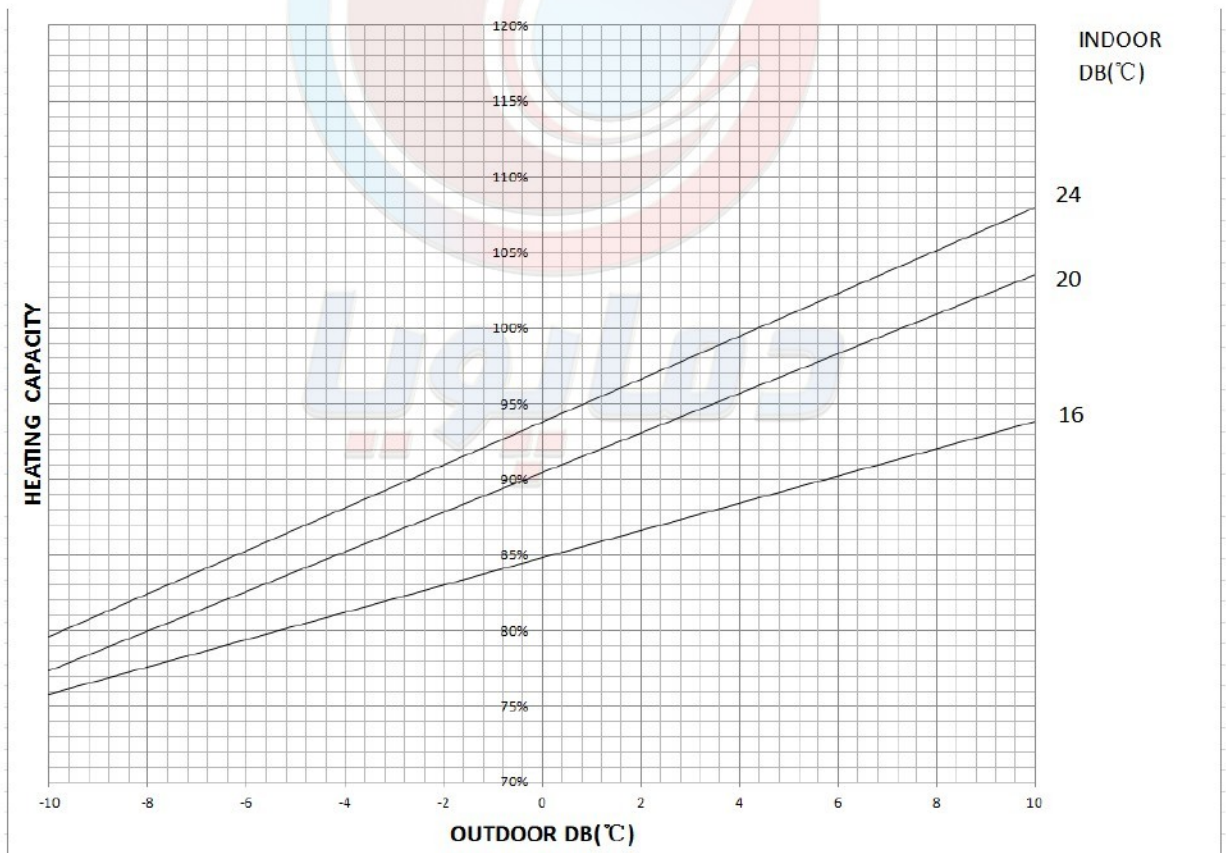
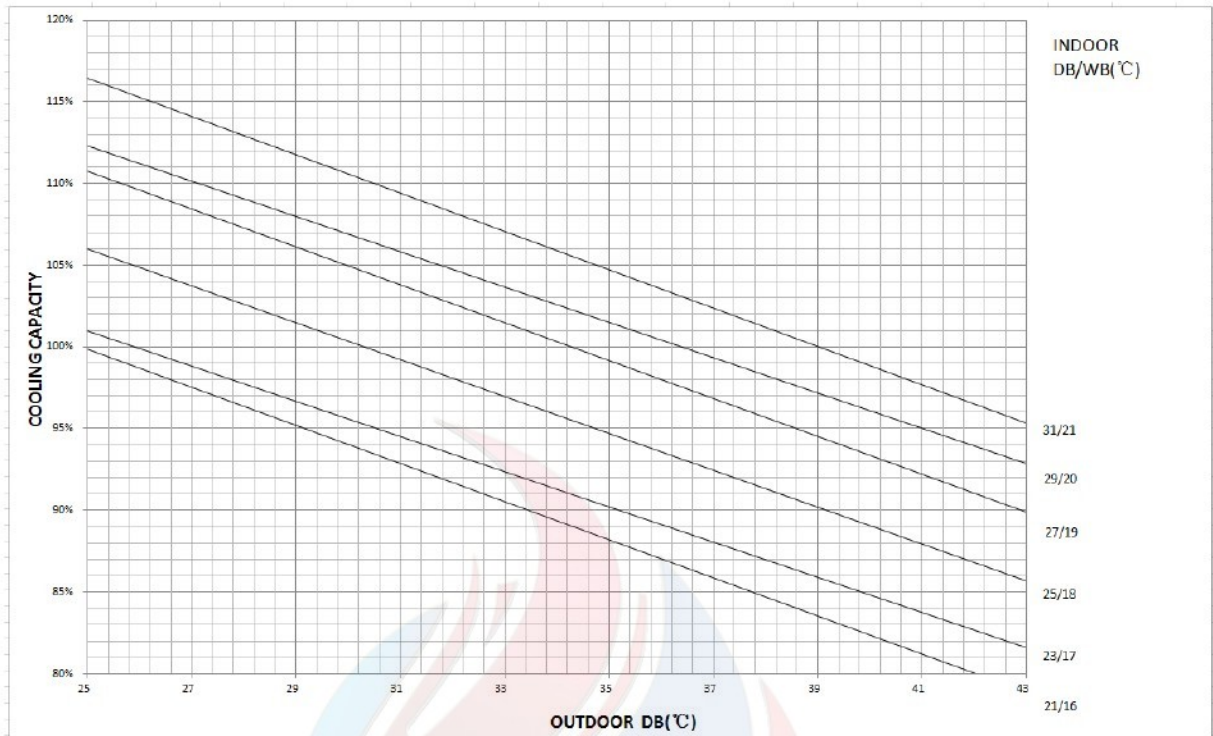

5. ELECTRICAL DATA

5-1. Electrical wiring diagrams

INDOOR UNIT: DUCT TYPE

18K

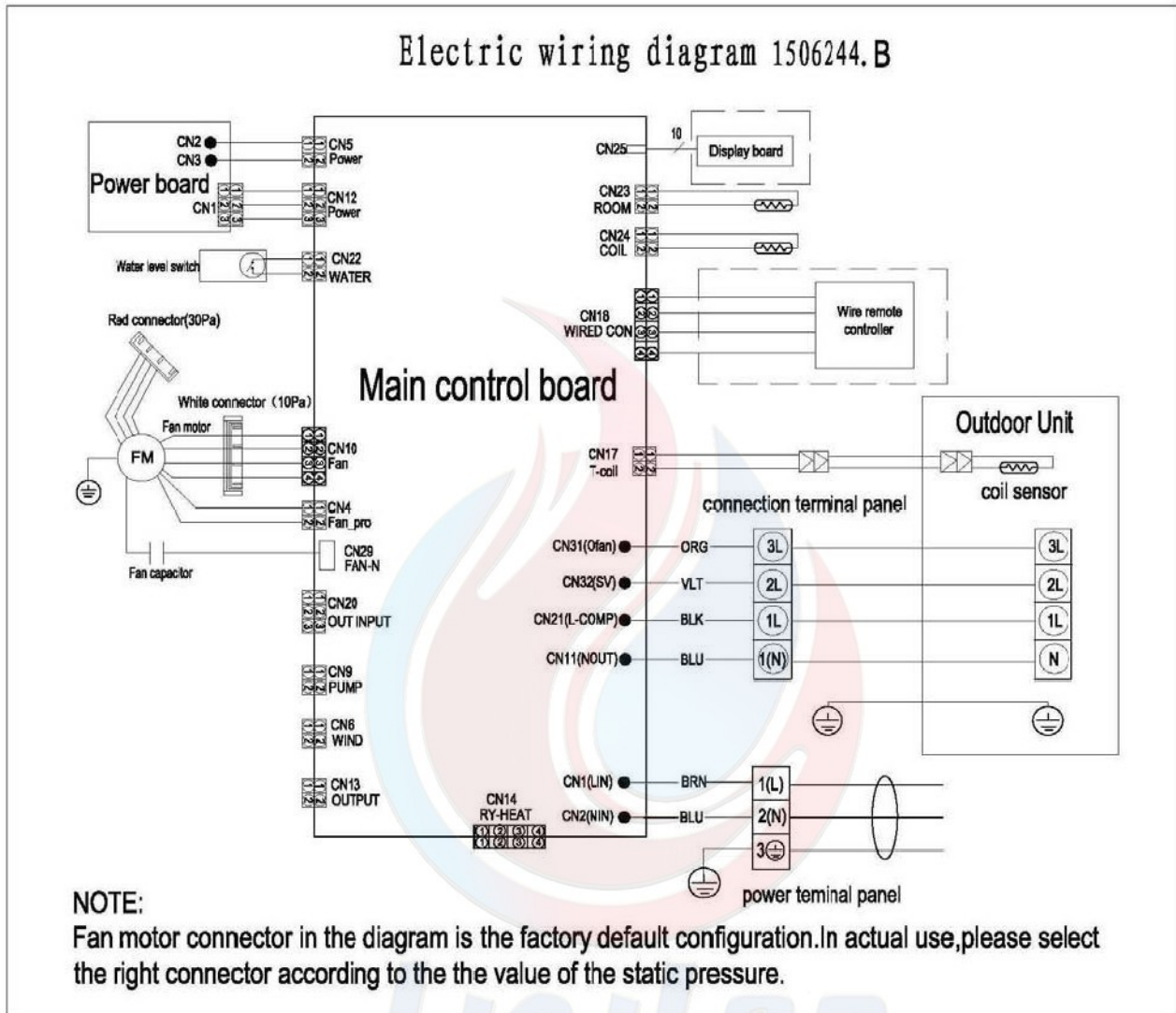

Electric wiring diagram 1820991. A

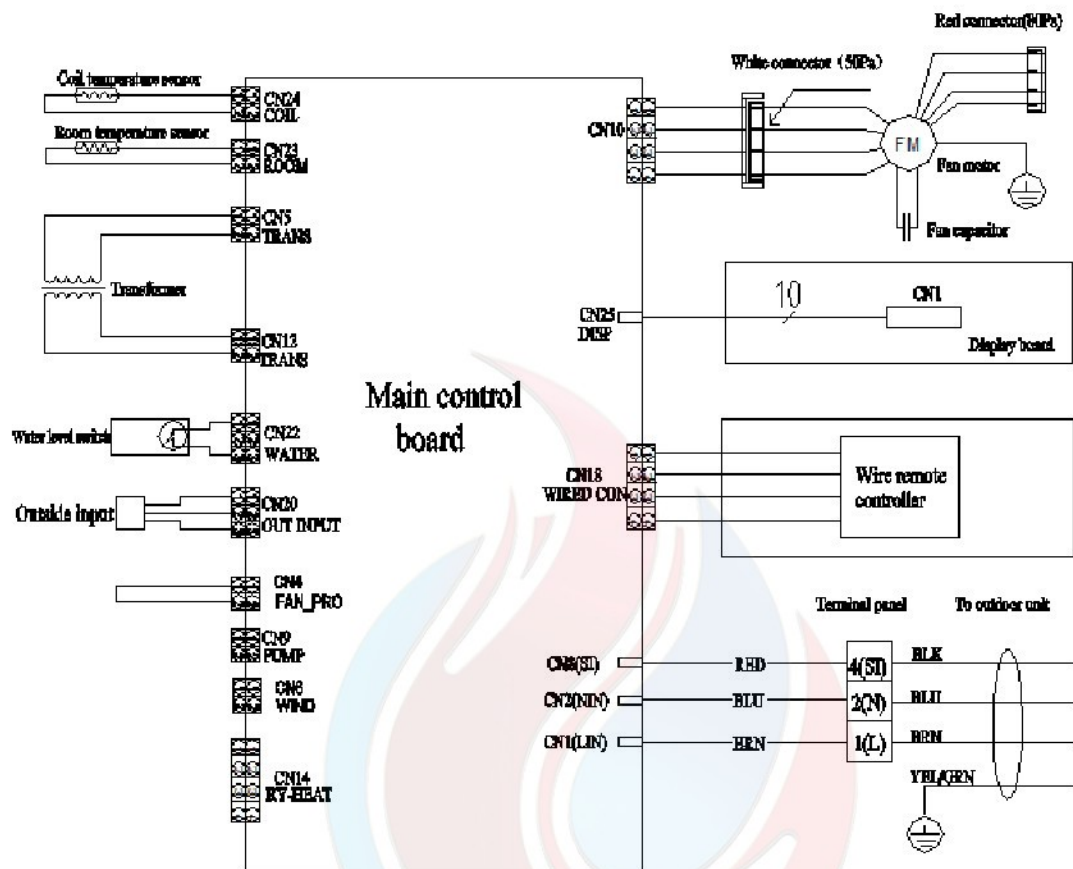

NOTE:

Fan motor connector in the diagram is the factory default configuration.

In actual use, please select the right connector according to the value of the static pressure.

Electric wiring diagram 1820993. A

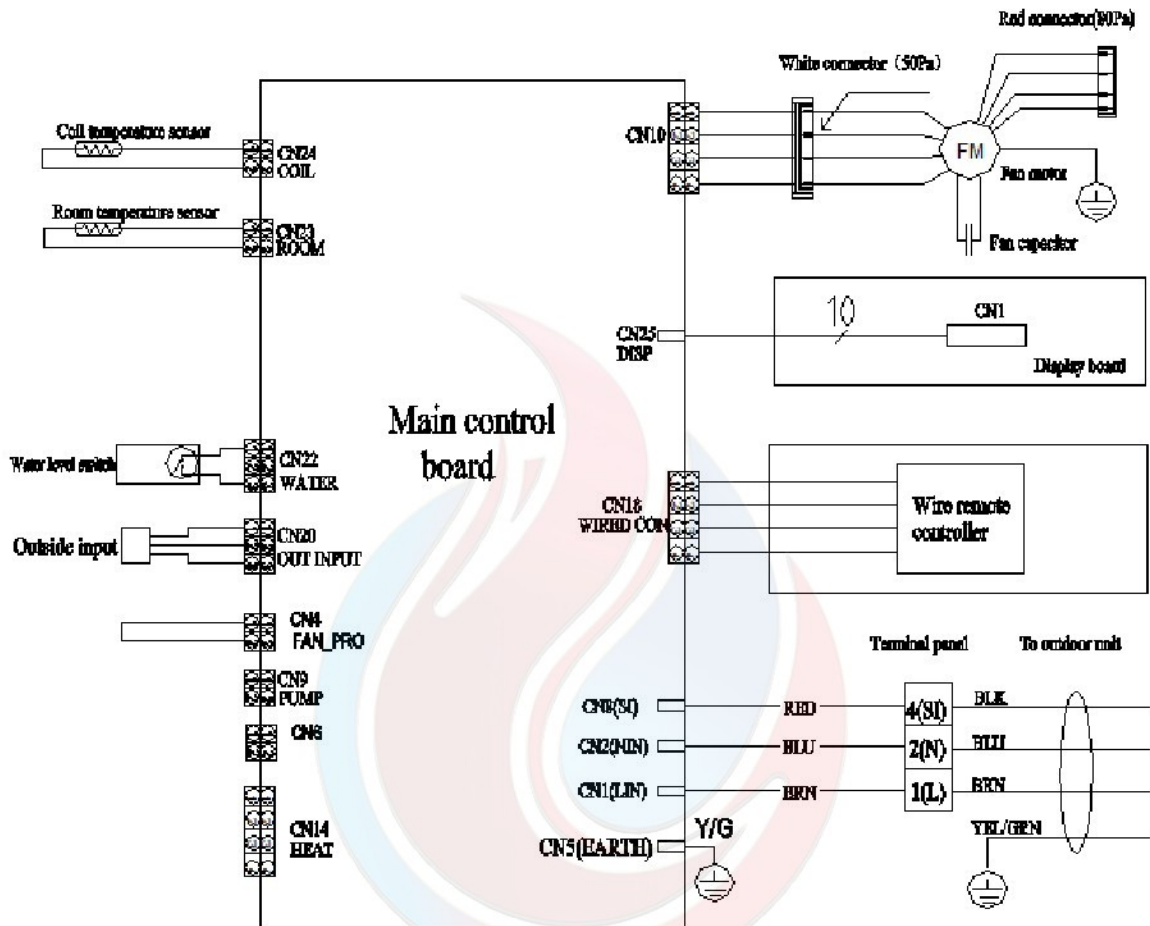

NOTE:

Fan motor connector in the diagram is the factory default configuration.

In actual use, please select the right connector according to the the value of the static pressure.

Electric wiring diagram 1821847. A

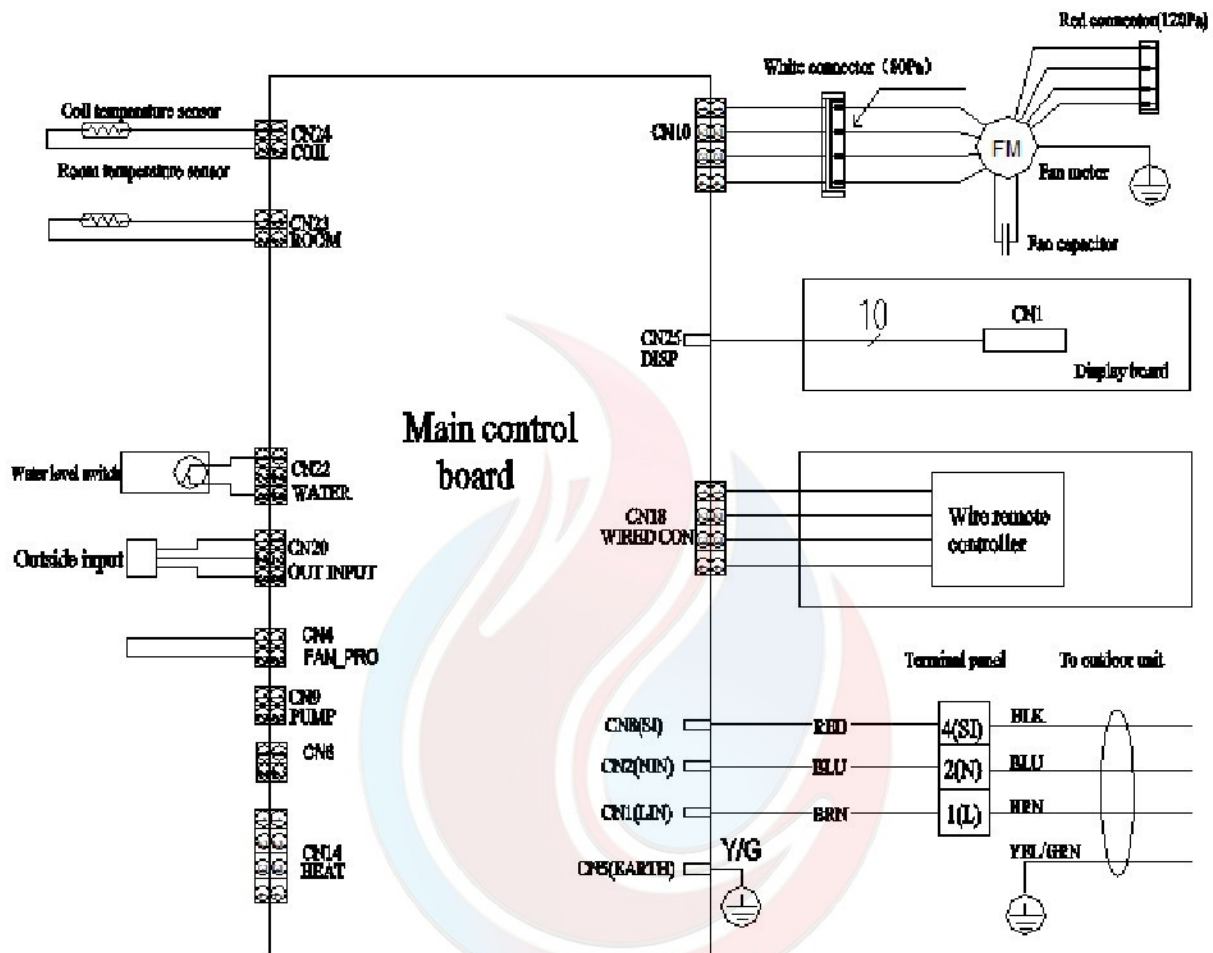

NOTE:

Fan motor connector in the diagram is the factory default configuration.

In actual use, please select the right connector according to the the value of the static pressure.

5. ELECTRICAL DATA

CASSETTE TYPE

18K

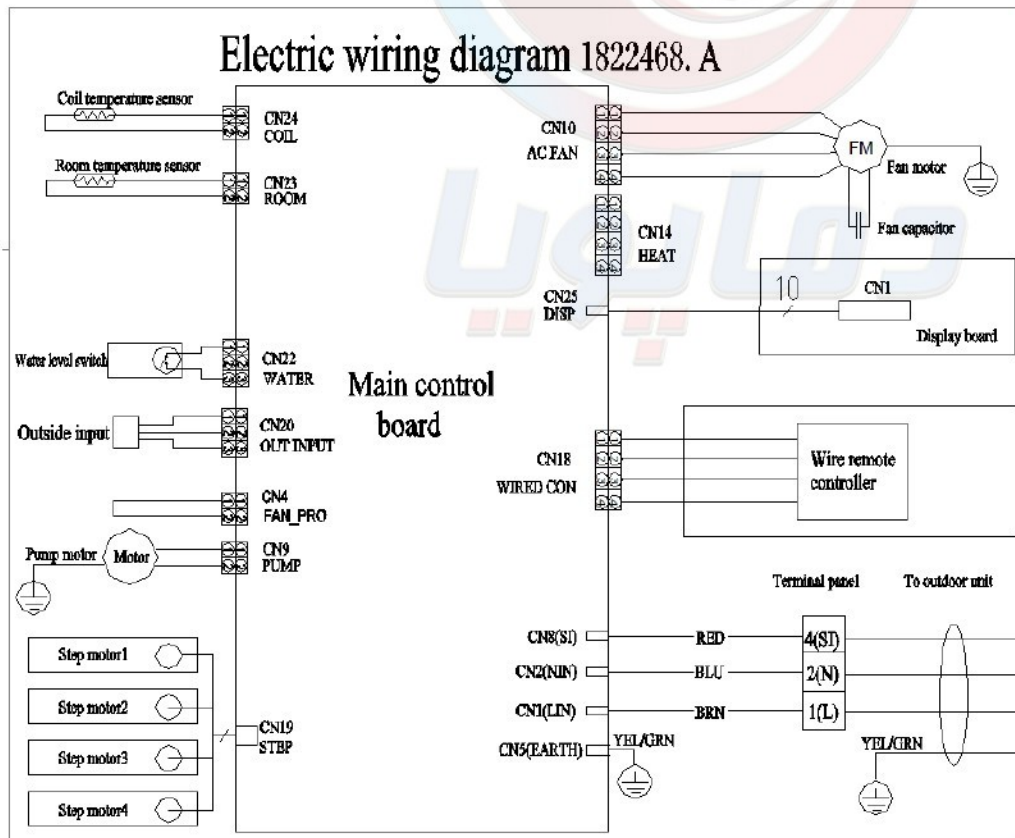
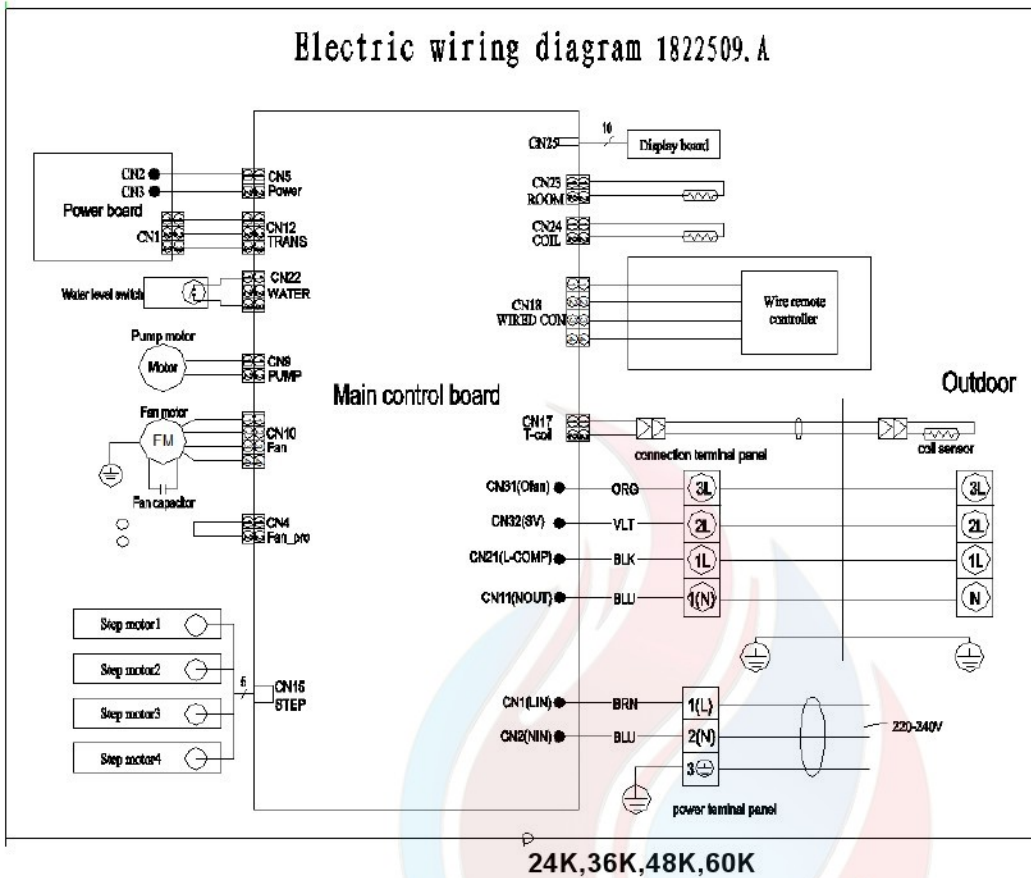

5. ELECTRICAL DATA

CEILING&FLOOR TYPE

18K

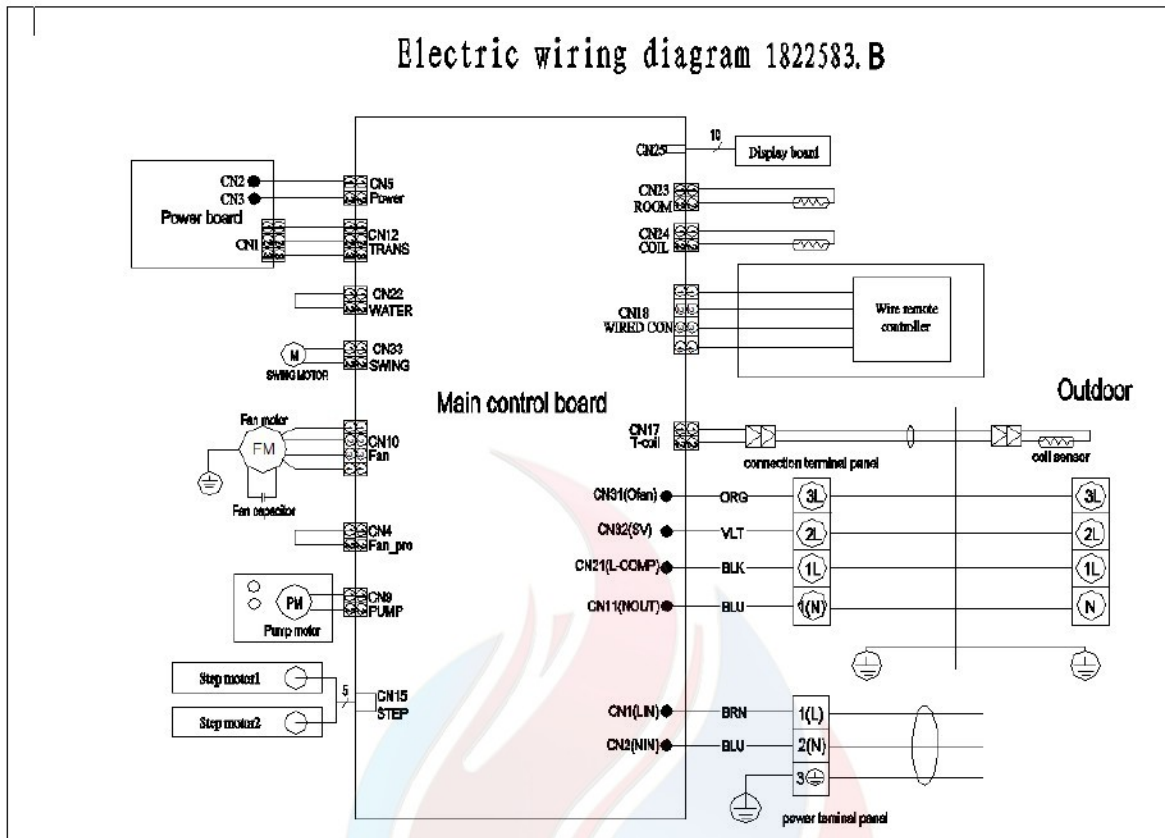

24K/36K/48K/60K

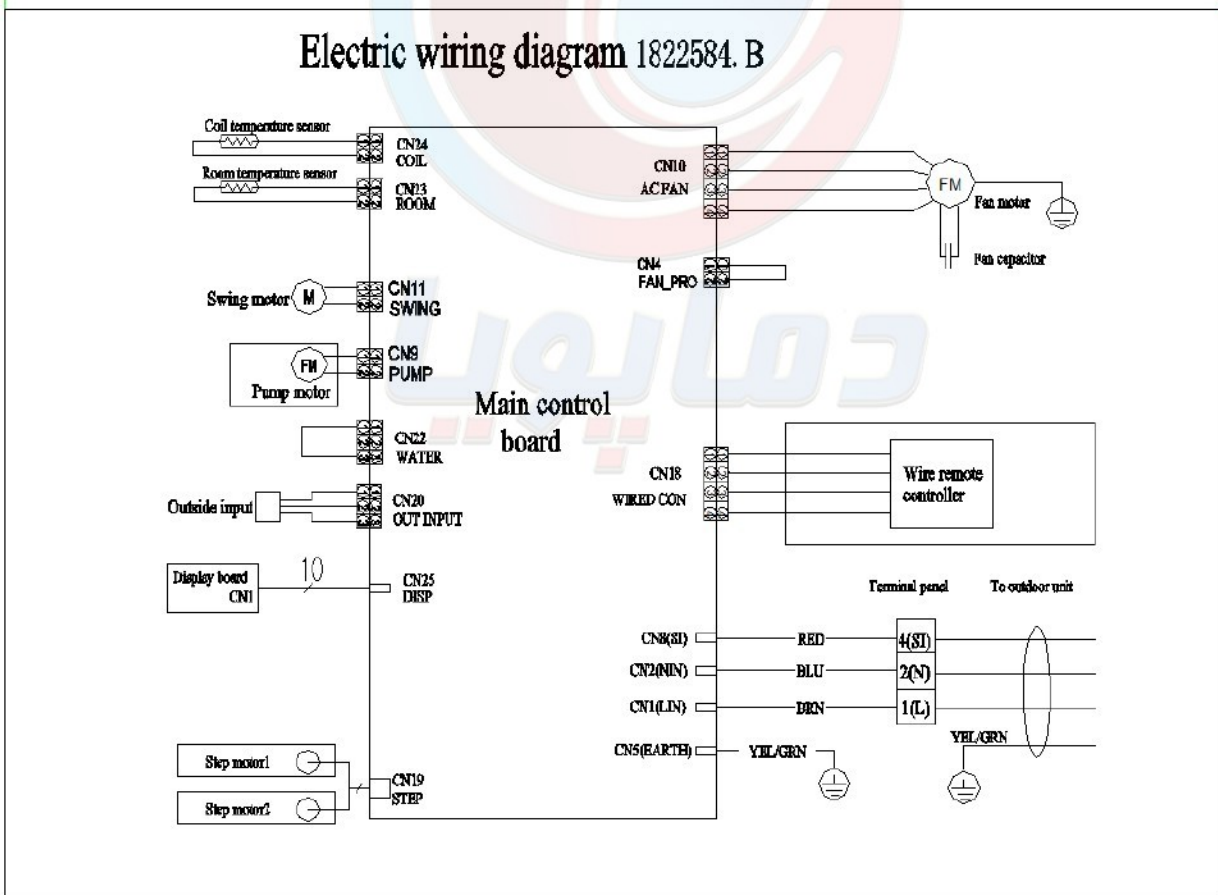

5. ELECTRICAL DATA

OUTDOOR UNIT

Low-Ambient Temperature Type

18K

Electric wiring diagram (1839132.B)

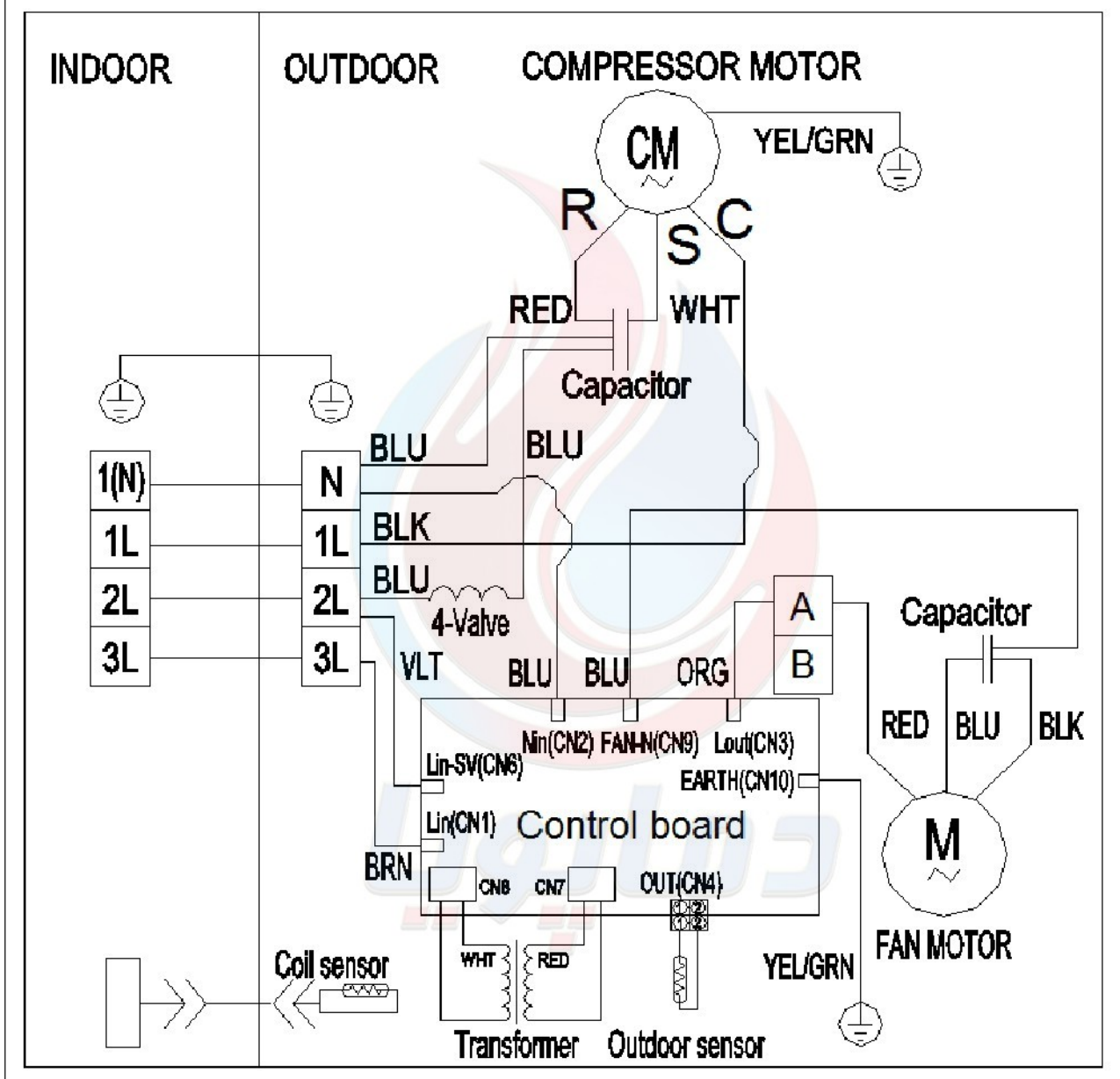

5. ELECTRICAL DATA

24K

Electric wiring diagram 1836788.A

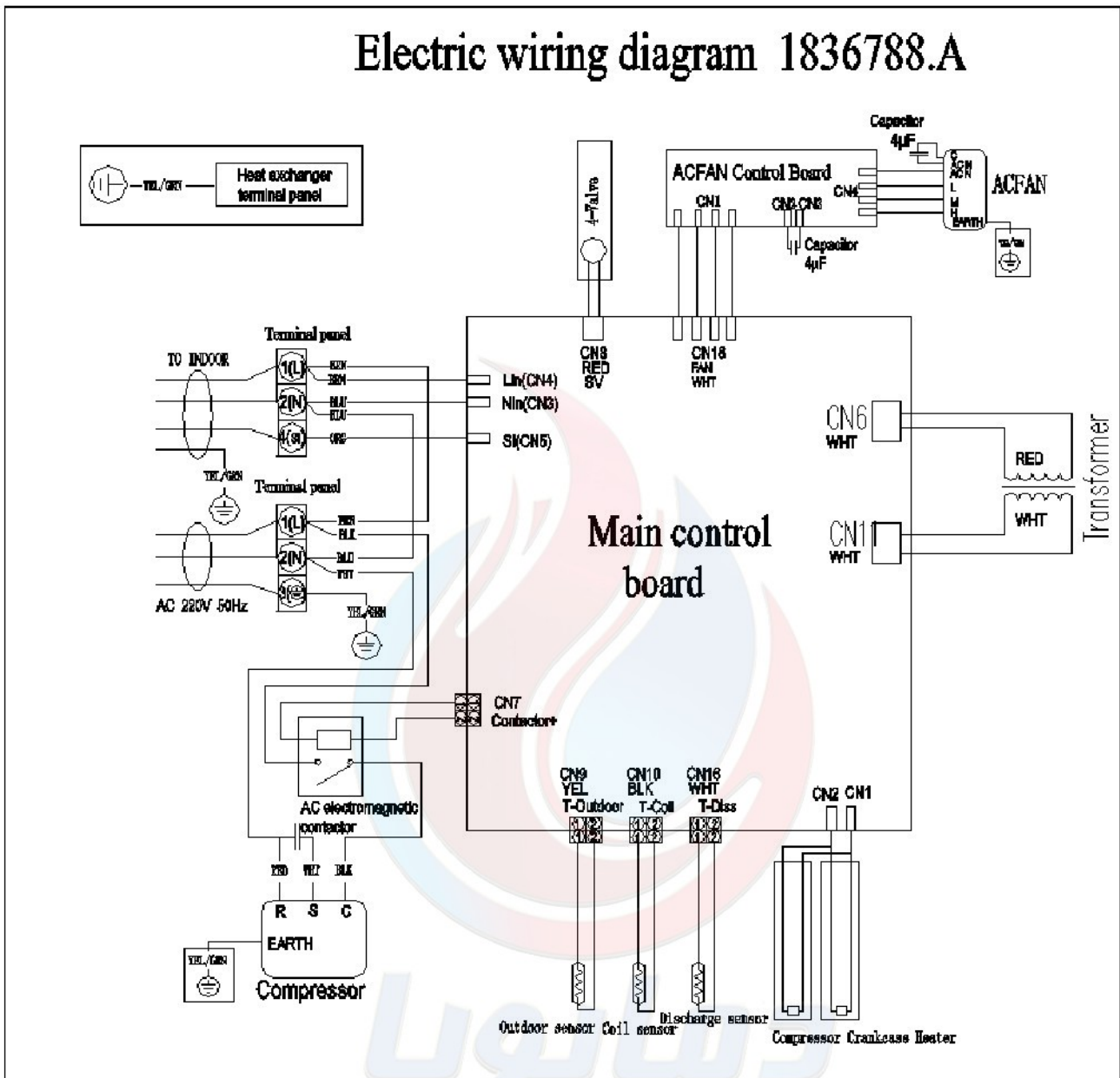

Electric wiring diagram 1836772.B

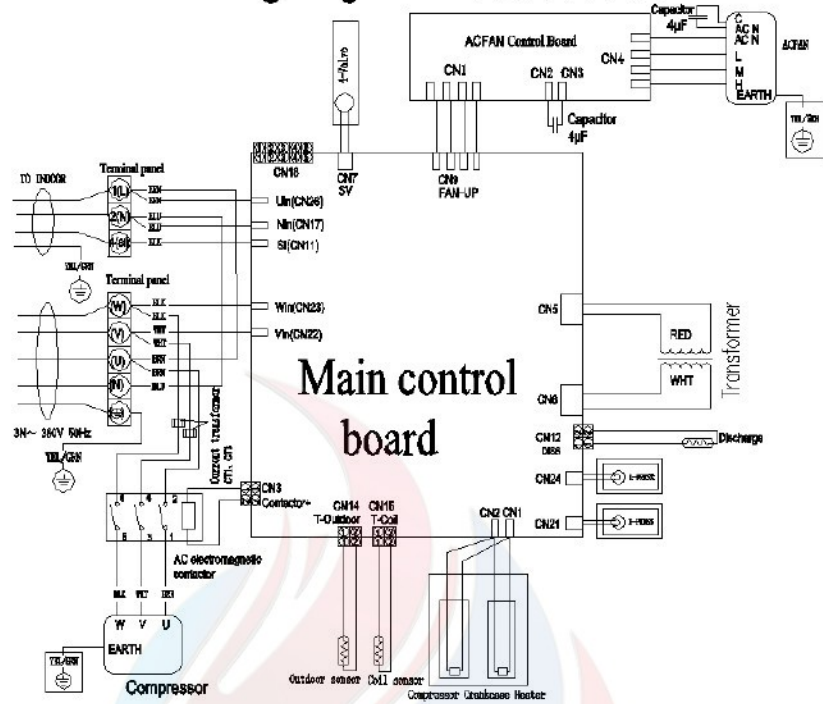

دما پویا

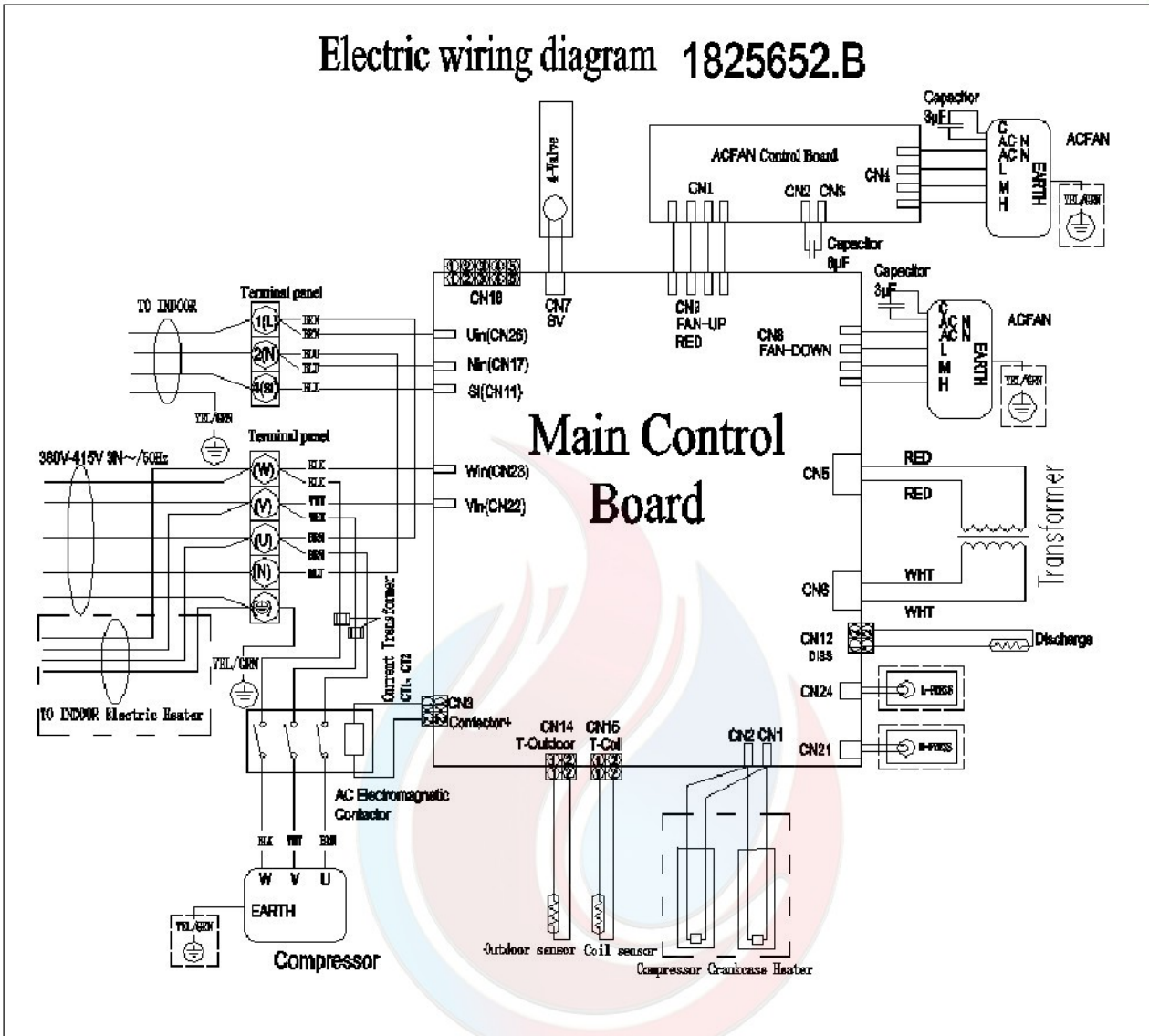

5. ELECTRICAL DATA

60K

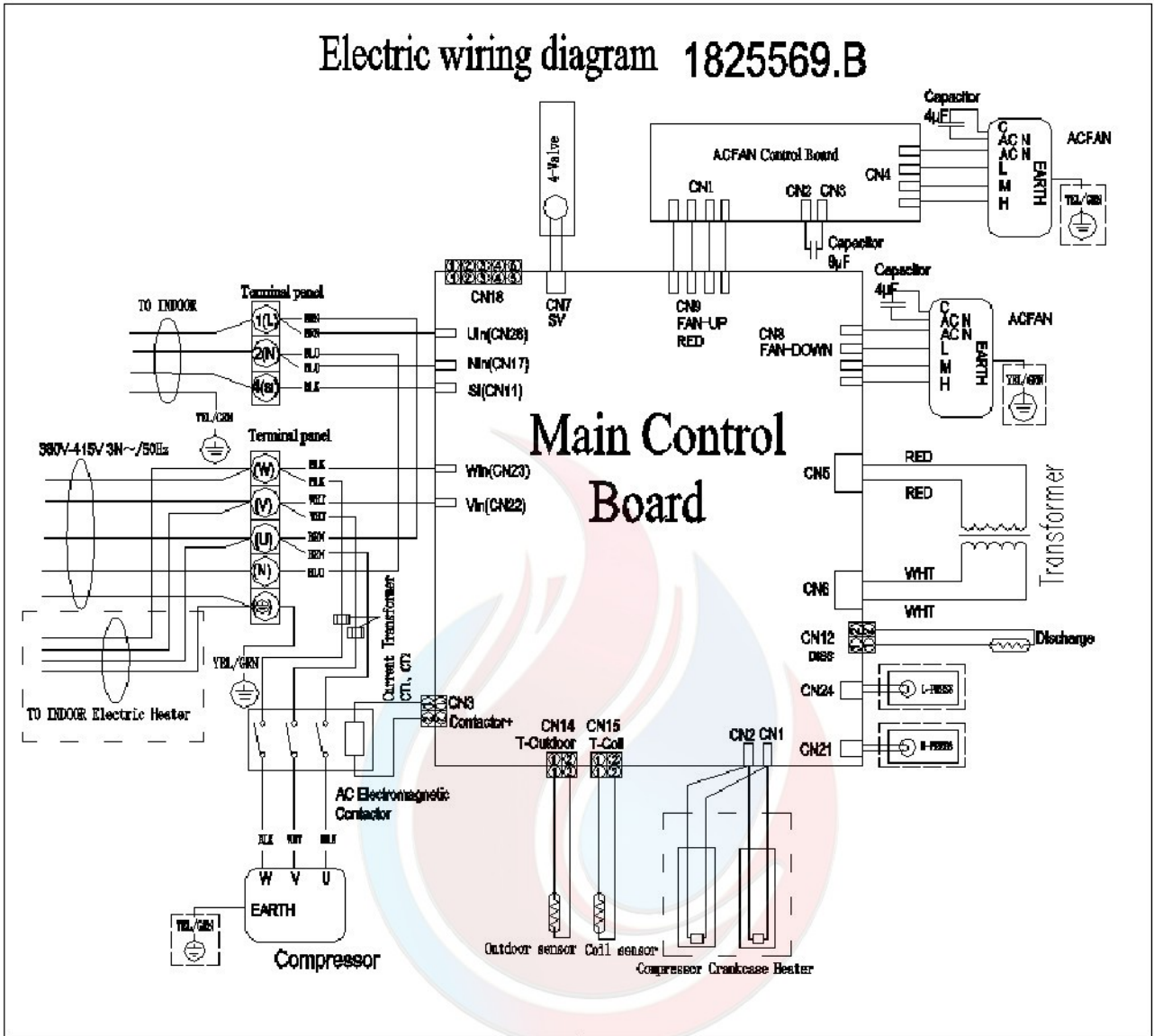

5. ELECTRICAL DATA

Ordinary Temperature Type

18K

CIRCUIT DIAGRAM (1506242, A)

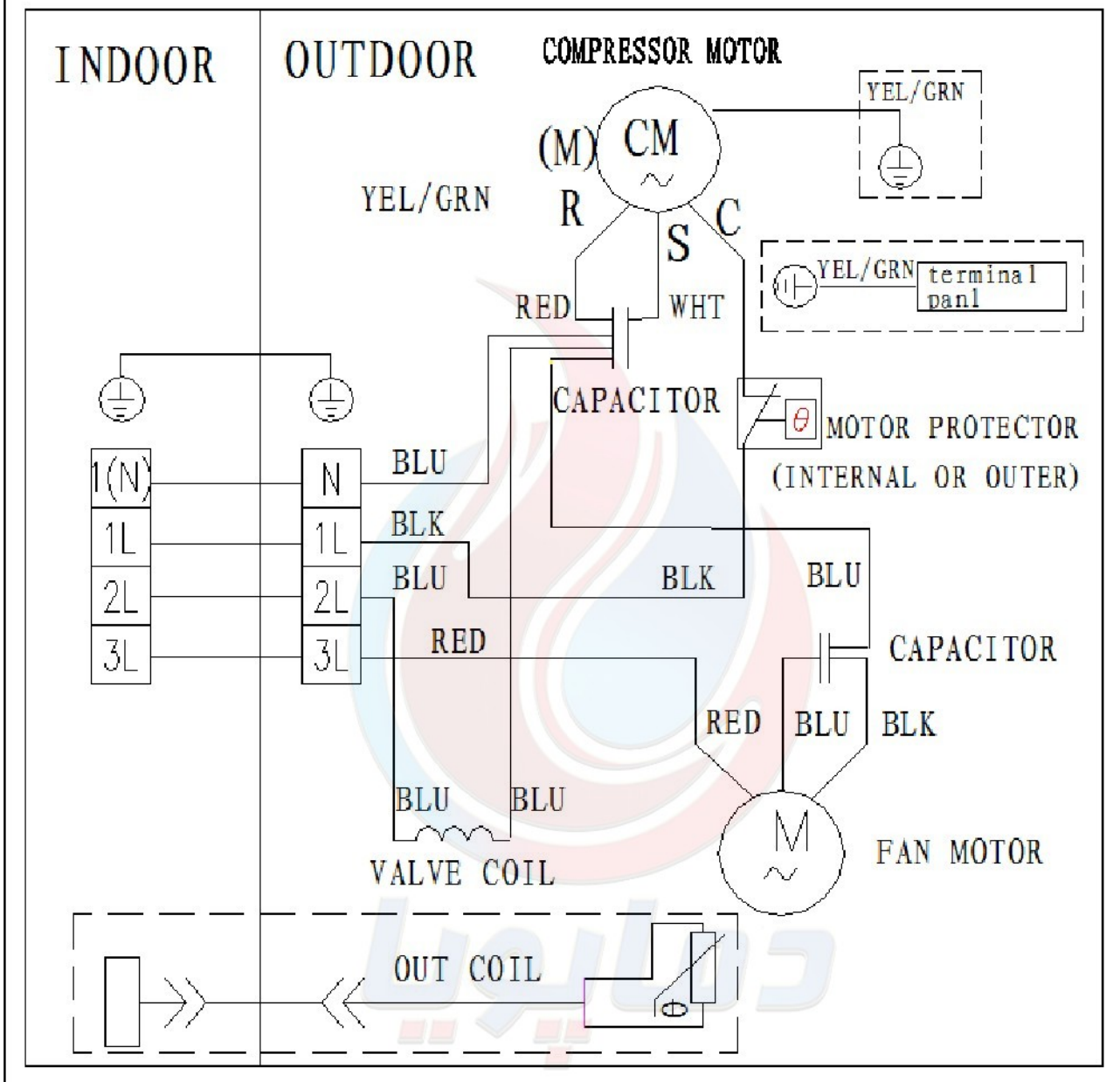

5. ELECTRICAL DATA

24K

Ordinary Temperature Type

Electric wiring diagram 1812202.A

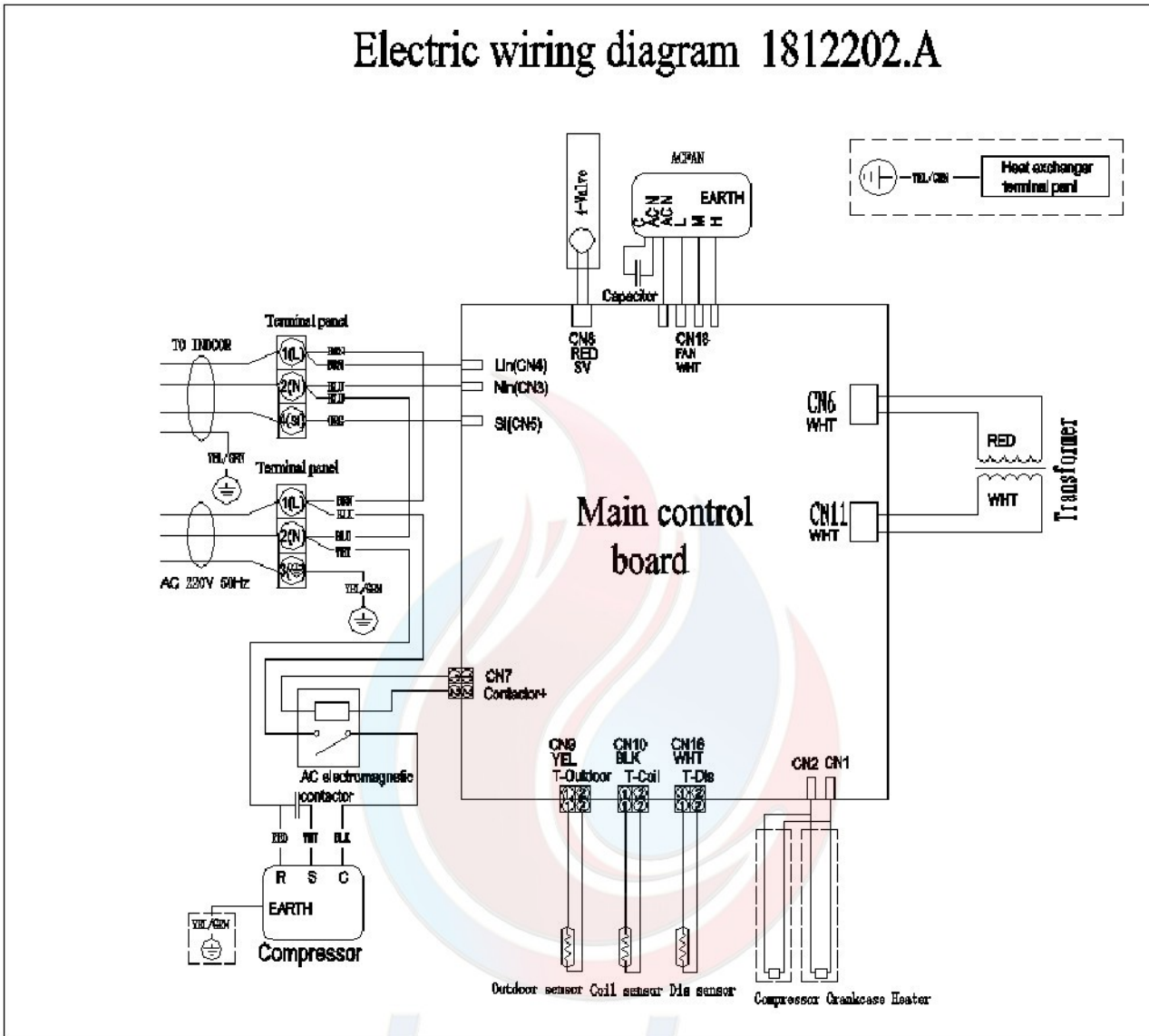

Electric wiring diagram 1817916.A

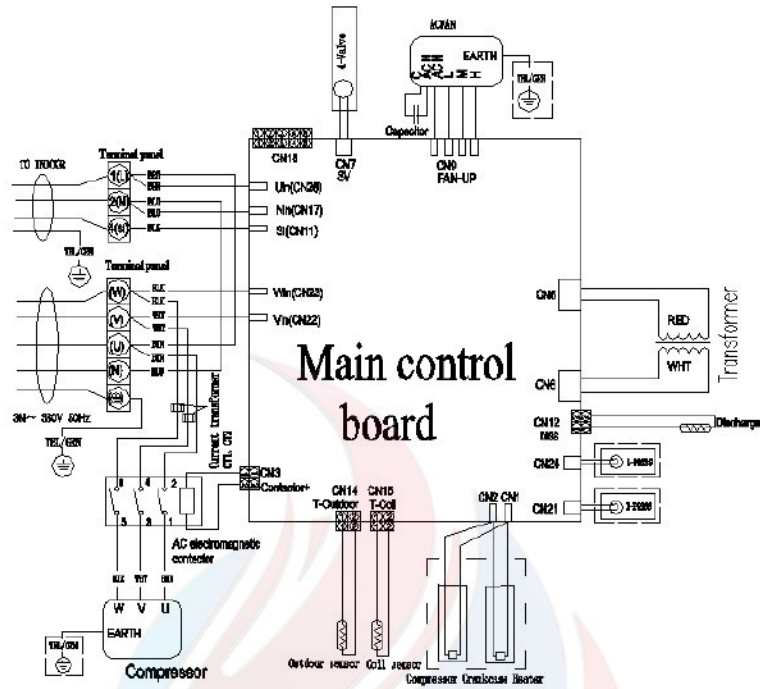

دما پویا

Electric wiring diagram 1817881.B

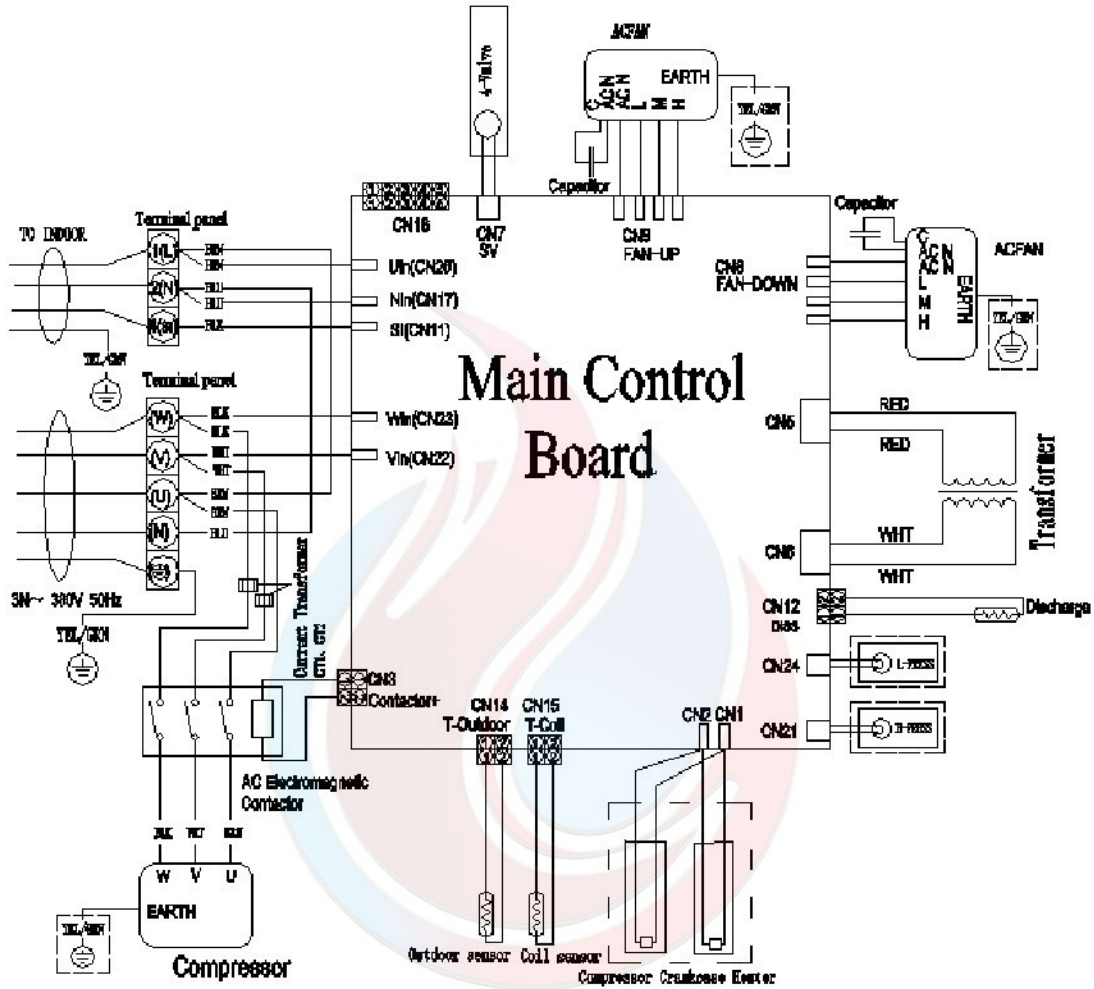

Electric wiring diagram 1817881.B

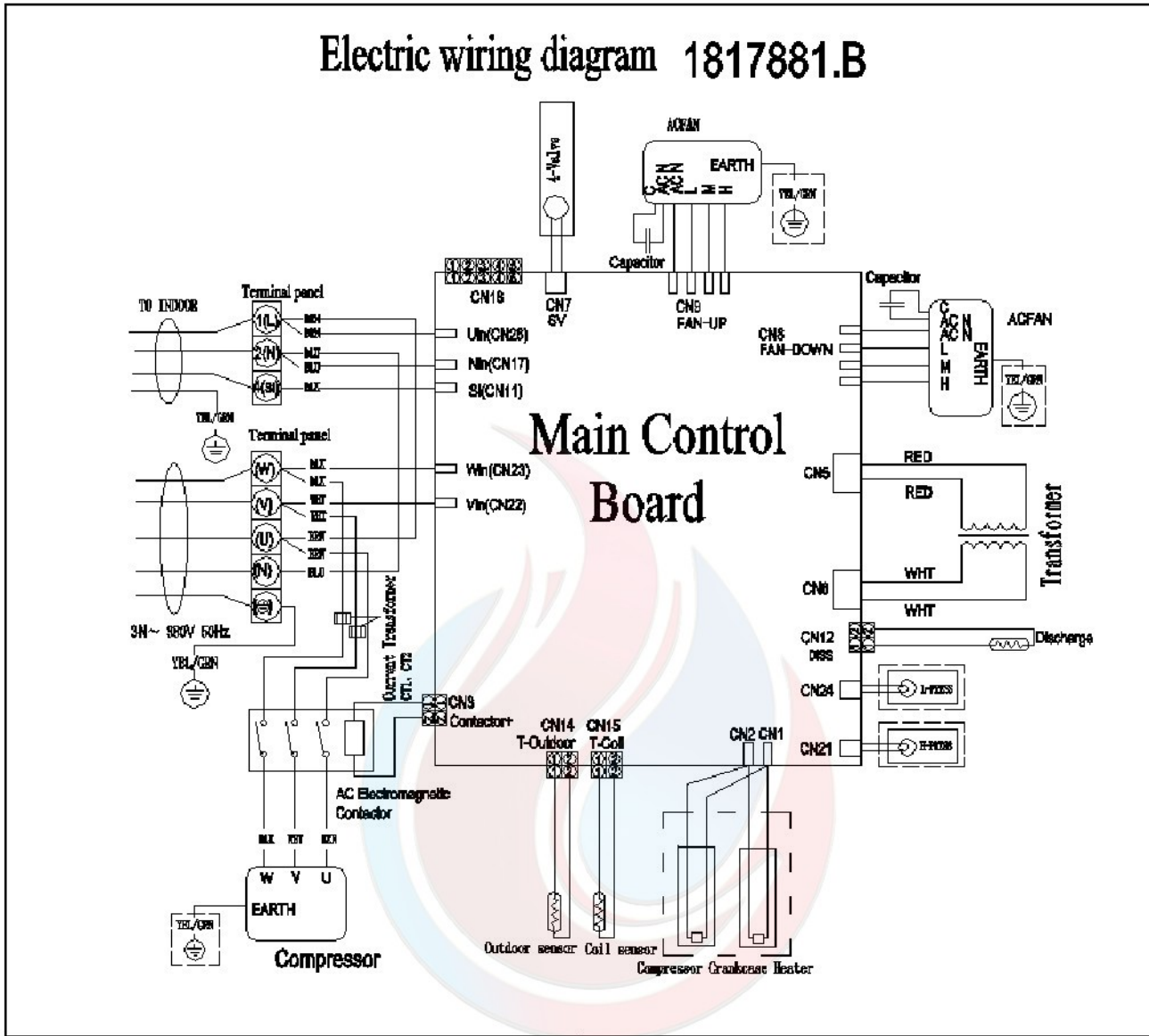

5. ELECTRICAL DATA

5-2. CONTROL BOARD

INDOOR UNIT:

18k

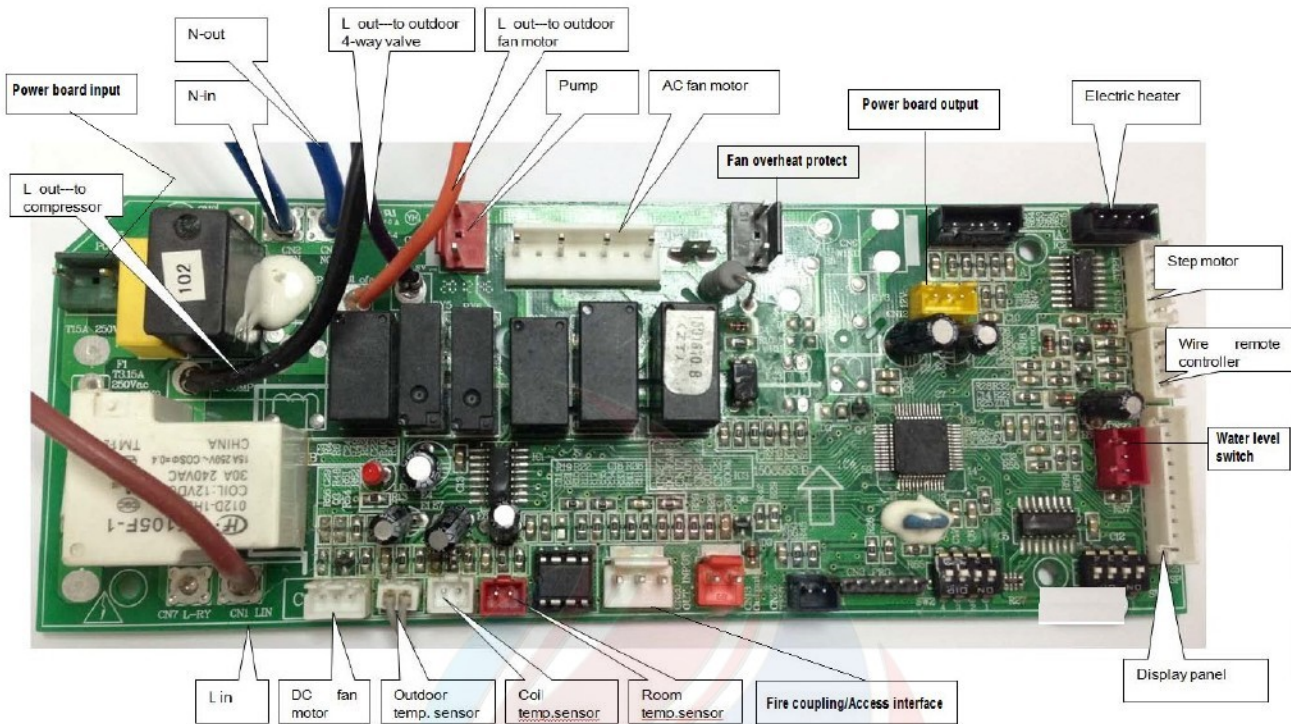

24k,36k,48k,60k

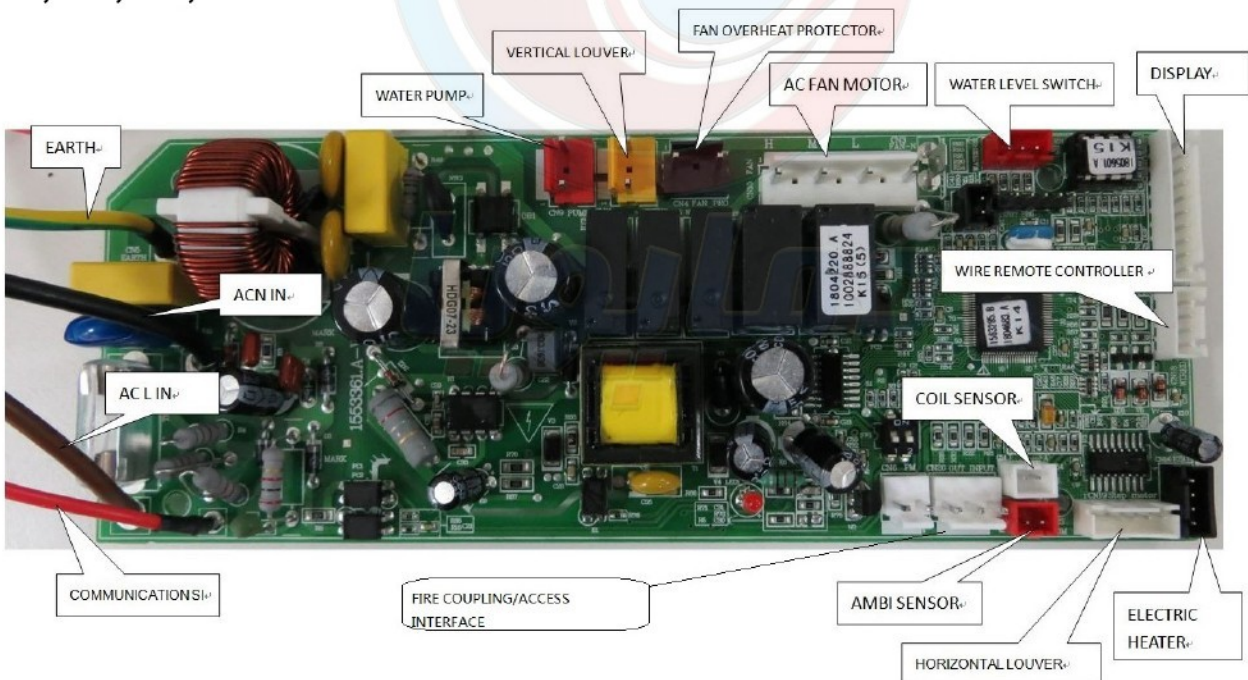

5. ELECTRICAL DATA

OUTDOOR UNIT

18K----no control board

24K

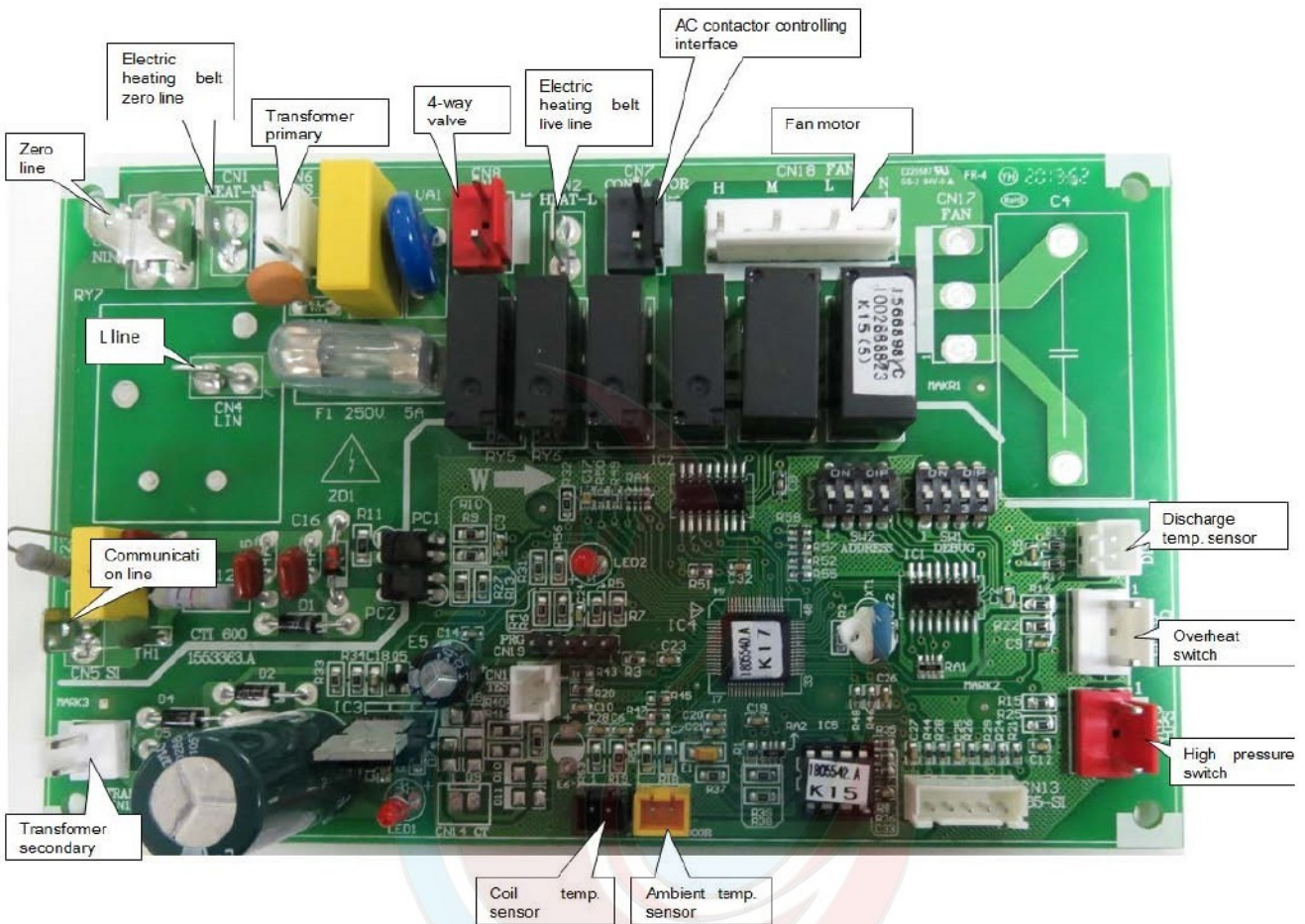

5. ELECTRICAL DATA

36K,48K,60K

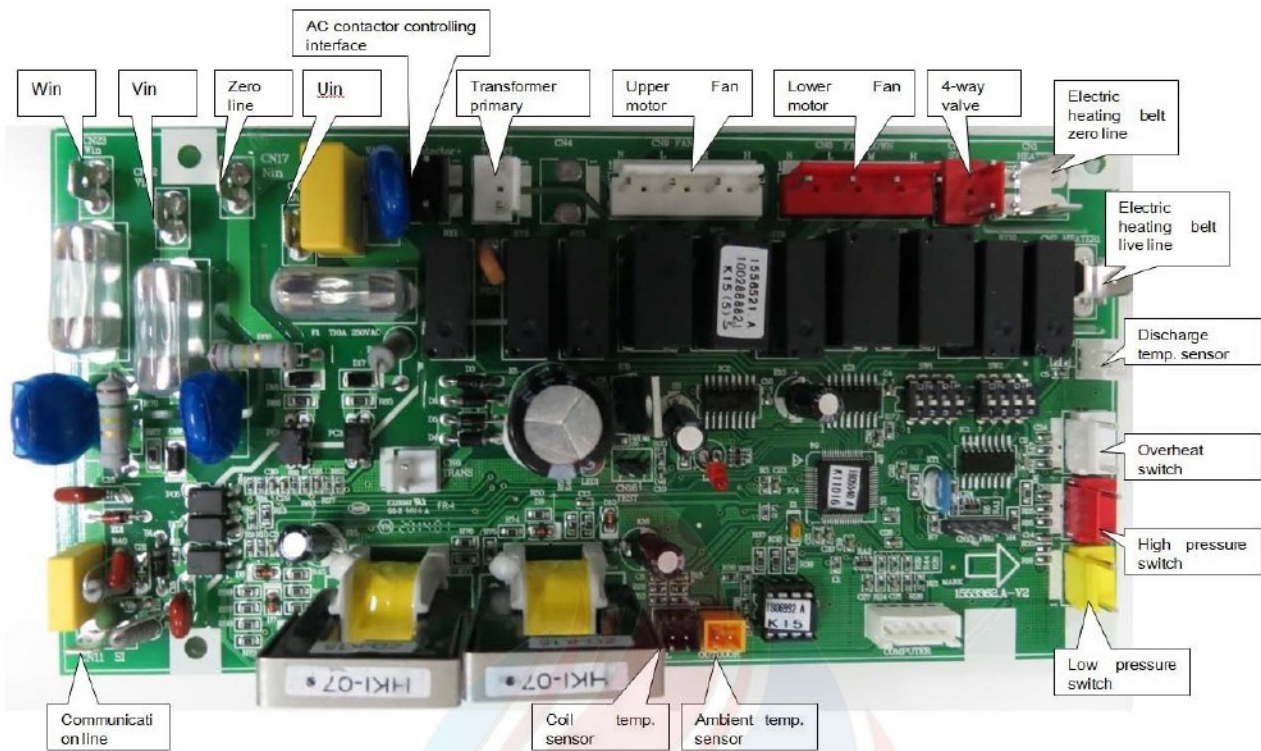

دما پویا

5. ELECTRICAL DATA

5-3. Dip Switch Setting

18K(INDOOR)

Dip Switch Setting 1506250.B

Mark of "■" indicates the position of dip switches.

Setting before Shipment	ON <input type="checkbox"/> <input type="checkbox"/> <input type="checkbox"/> <input type="checkbox"/> OFF <input checked="" type="checkbox"/> <input checked="" type="checkbox"/> <input checked="" type="checkbox"/> <input checked="" type="checkbox"/>
	1 2 3 4
SW1	

SW1	Optional Function Setting				
Setting is required, when optional functions are required.					
Function	Normal defrosting model	Forced defrosting model	Function	Normal model	Forced cooling
Setting Position	ON <input type="checkbox"/> <input type="checkbox"/> <input type="checkbox"/> <input type="checkbox"/> OFF <input checked="" type="checkbox"/> <input type="checkbox"/> <input type="checkbox"/> <input type="checkbox"/>	ON <input checked="" type="checkbox"/> <input type="checkbox"/> <input type="checkbox"/> <input type="checkbox"/> OFF <input type="checkbox"/> <input type="checkbox"/> <input type="checkbox"/> <input type="checkbox"/>	Setting Position	ON <input type="checkbox"/> <input checked="" type="checkbox"/> <input type="checkbox"/> <input type="checkbox"/> OFF <input type="checkbox"/> <input type="checkbox"/> <input type="checkbox"/> <input type="checkbox"/>	ON <input type="checkbox"/> <input checked="" type="checkbox"/> <input type="checkbox"/> <input type="checkbox"/> OFF <input type="checkbox"/> <input type="checkbox"/> <input type="checkbox"/> <input type="checkbox"/>

24K,36K,48K,60K(OUTDOOR)

Dip Switch Setting of Outdoor Unit 1483595 .A

TURN OFF all power sources before setting.
Without turning OFF, the switches do not work and the contents of the setting are invalid, but except the 3th of dip switches ,it must be turned on when the power is on.
Mark of "■" indicates the position of dip switches.

SW1	Optional Function Setting				
Setting is required, when optional functions are required.					
Function	Automatic defrosting	Manual defrosting	Function	Refrigerant recovery start	
Setting Position	ON <input type="checkbox"/> <input type="checkbox"/> <input type="checkbox"/> <input type="checkbox"/> OFF <input checked="" type="checkbox"/> <input type="checkbox"/> <input type="checkbox"/> <input type="checkbox"/>	ON <input checked="" type="checkbox"/> <input type="checkbox"/> <input type="checkbox"/> <input type="checkbox"/> OFF <input type="checkbox"/> <input type="checkbox"/> <input type="checkbox"/> <input type="checkbox"/>	Setting Position	ON <input type="checkbox"/> <input type="checkbox"/> <input checked="" type="checkbox"/> <input type="checkbox"/> → ON <input type="checkbox"/> <input type="checkbox"/> <input checked="" type="checkbox"/> <input type="checkbox"/> OFF <input type="checkbox"/> <input type="checkbox"/> <input type="checkbox"/> <input type="checkbox"/> OFF <input type="checkbox"/> <input type="checkbox"/> <input type="checkbox"/> <input type="checkbox"/>	
Function	Silence mode unavailable	Silence mode available	Function	Normal cooling	Forced cooling
Setting Position	ON <input type="checkbox"/> <input type="checkbox"/> <input type="checkbox"/> <input type="checkbox"/> OFF <input type="checkbox"/> <input checked="" type="checkbox"/> <input type="checkbox"/> <input type="checkbox"/>	ON <input type="checkbox"/> <input checked="" type="checkbox"/> <input type="checkbox"/> <input type="checkbox"/> OFF <input type="checkbox"/> <input type="checkbox"/> <input type="checkbox"/> <input type="checkbox"/>	Setting Position	ON <input type="checkbox"/> <input type="checkbox"/> <input type="checkbox"/> <input checked="" type="checkbox"/> OFF <input type="checkbox"/> <input type="checkbox"/> <input type="checkbox"/> <input type="checkbox"/>	ON <input type="checkbox"/> <input type="checkbox"/> <input type="checkbox"/> <input checked="" type="checkbox"/> OFF <input type="checkbox"/> <input type="checkbox"/> <input type="checkbox"/> <input type="checkbox"/>

5. ELECTRICAL DATA

5-4 Static Pressure Setting(only for duct type)

CHANGE OF STATIC PRESSURE

The static pressure outside the indoor unit can be chosen .

You can change the static pressure by changing the fan motor terminal which refer to following Fig.below :

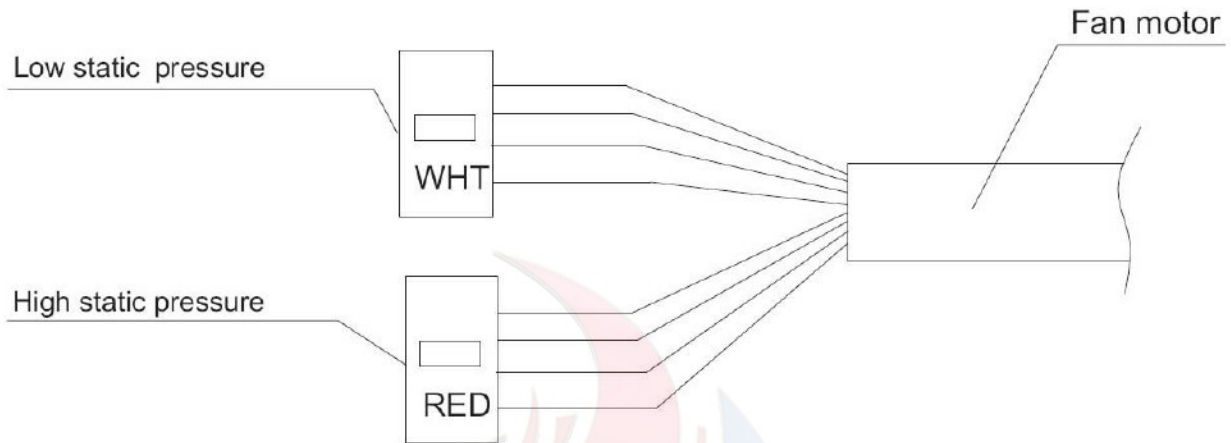

Model	Low static pressure	High static pressure
18K	10Pa	30Pa
24K, 36K	50Pa	80Pa
48K, 60K	80Pa	120Pa

Note: Default Settings is low static pressure by factory.

The noise under high static pressure is higher than static pressure .

دما پویا

5. ELECTRICAL DATA

5-5. System Parameter Adjustment

Internal control parameter adjustment can be performed.

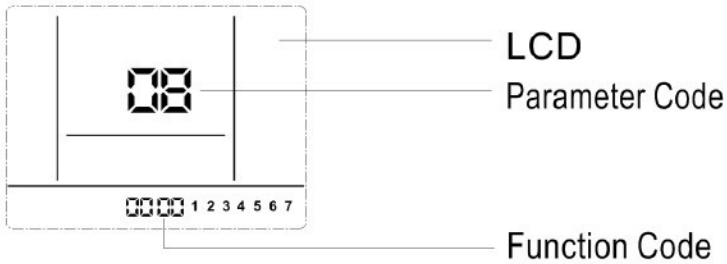

OPERATION:

① Hold down both "MODE" button and "ADD.FUNC." button for 3 seconds, symbol  and parameter number blinking at the same time.

② Press "▲" "▼" button to adjust parameter number until display "17".

And press "ENTER" button to entering system parameter adaption state, symbol  stop blinking.

③ Select desired parameter code by pressing ▲/▼ button following the table below.

Press the "ENTER" button to rewrite the parameter values using "▲/▼" buttons.

PARAMETER CODE	PARAMETER DESCRIPTION	PARAMETER VALUE&REPRESENTATION		NOTE
		DATA TYPE	REPRESENTATION(FUNCTION CODE)	
1	Self Recovery of Power Break	Integer	0: Cancel Self Recovery of Power Break function; 1: Self Recovery of Power Break; others: invalid	
2	Temperature Type	Integer	0: Centigrade Temperature; 1: Fahrenheit Temperature; others: invalid	
3	Temperature Display Type	Integer	0: Default display set temperature; 1: Default display room temperature; others: invalid	
4	Ratio of ambient temperature sensed by indoor temperature sensor(cooling mode)	Integer	0~10valid, more than 10 default is 10 0: 0%; 1: 10%; ...; 10: 100%	0- entirely use temperature sensed by remote controller; 1- entirely use temperature sensed by indoor unit
5	Filter Clean Indicate	Integer	0: Cancel Filter Clean Indicate function; 1: Set Filter Clean Indicate function; others: invalid	
6	Filter Clean Time Set	Integer	0~32, more than 32 default is 32*1000h	
7	Installation Height	Integer	0~10m, more than 10m default is 10	
8	Cooling Temperature Compensation (indoor unit temperature sensor)	Integer	0: 0℃; 1: -0.5℃; 2: -1℃; 3: -1.5℃; 4: -2℃; 5: -2.5℃; 6: -3℃; 7: -3.5℃; 8: -4℃; 9: -4.5℃; 10: -5℃; (the wired controller displays integer with the symbol)	
9	Heating Temperature Compensation (indoor unit temperature sensor)	Integer	0: 0℃; 1: -0.5℃; 2: -1℃; 3: -1.5℃; 4: -2℃; 5: -2.5℃; 6: -3℃; 7: -3.5℃; 8: -4℃; 9: -4.5℃; 10: -5℃; (the wired controller displays integer with the symbol)	
10	Static Pressure Set	Integer	1~240, function code=static pressure more than the limit static pressure default the limit static pressure, Default is 0(default static pressure, related to models)	DUCT TYPE(DC MOTOR)
12	Ratio of temperature sensed by indoor temperature sensor(Heating mode)	Integer	0~10valid, more than 10 default is 10 0: 0%; 1: 10%; ...; 10: 100%	
13	Temperature Adjustment-Cooling	Character	-10~10℃ (Single Character with symbol)	0- entirely use temperature sensed by remote controller; 1-entirely use temperature sensed by indoor unit
14	Temperature Adjustment-Heating	Character	-10~10℃ (Single Character with symbol)	
18	Cooling/Heating Temperature Limit	Integer	=0, Cooling/Heating Temperature Limit are all Invalid	

5. ELECTRICAL DATA

PARAMETER CODE	PARAMETER DESCRIPTION	PARAMETER VALUE&REPRESENTATION		NOTE
		DATA TYPE	REPRESENTATION(FUNCTION CODE)	
			=1. Cooling Temperature Limit is valid, Heating Temperature Limit is invalid =2. Cooling Temperature Limit is invalid, Heating Temperature Limit is valid =3. Cooling/Heating Temperature Limit are all valid	
19	The Lowest Set Temperature in Cooling Mode	Integer	SET VALUE=Actual temperature (16 °C-32 °C)	
20	The Highest Set Temperature in Heating Mode	Integer	SET VALUE=Actual temperature (16 °C-32 °C)	



Parameter code will not display if the indoor unit is not equipped with this function. Please refer to indoor unit manual to check whether this function is effective.

EXIT:

Press "ON/OFF" button to exit, or no operation within 30 seconds automatically exit.

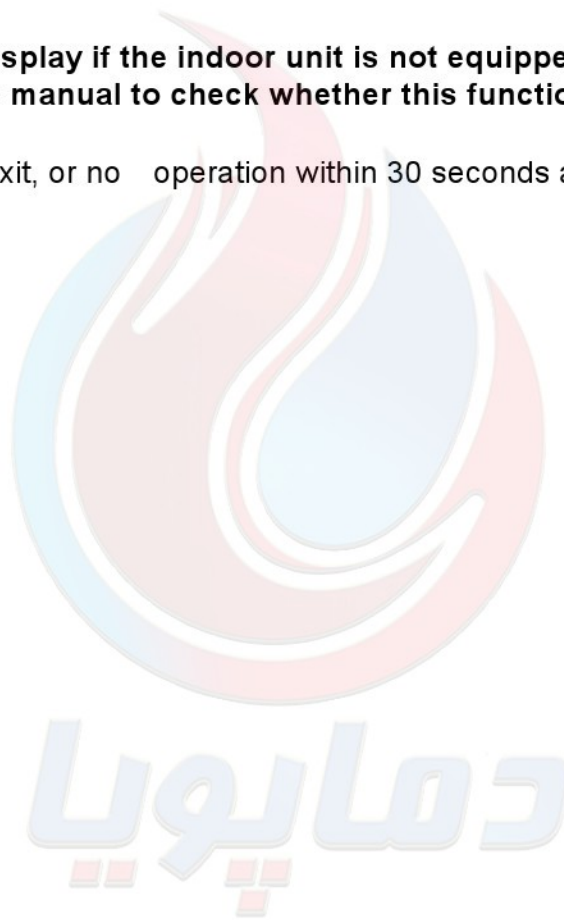

5. ELECTRICAL DATA

5-6. Sensor parameter

1 THE PARAMETER OF OUTDOOR COMPRESSOR DISCHARGE TEMPERATURE SENSOR:
($R_0=187.25K \pm 6.3\%$; $R_{100}=3.77K \pm 2.5K$; $B_0/100=3979K \pm 1\%$)

2 THE PARAMETER OF THE OTHER SENSOR IN INDOOR AND OUTDOOR UNIT:

T [°C]	Rmin [K Ω]	Rnom [K Ω]	Rmax [K Ω]	DR(MIN)%	DR(MAX)%
-30	908.2603	985.5274	1065.1210	-7.84	7.47
-29	855.3955	927.6043	1001.9150	-7.78	7.42
-28	805.9244	873.4324	924.8368	-7.73	5.56
-27	759.6097	822.7471	887.5944	-7.67	7.31
-26	716.2320	775.3041	835.9165	-7.62	7.25
-25	675.5881	730.8775	787.5529	-7.56	7.20
-24	637.4902	689.2583	742.2720	-7.51	7.14
-23	601.7645	650.2533	699.8601	-7.46	7.09
-22	568.2499	613.6835	660.1191	-7.40	7.03
-21	536.7970	579.3832	622.8658	-7.35	6.98
-20	507.2676	547.1989	587.9307	-7.30	6.93
-19	497.5332	516.9882	555.1565	-3.76	6.88
-18	453.4748	488.6192	524.3977	-7.19	6.82
-17	428.9819	461.9693	495.5191	-7.14	6.77
-16	405.9517	436.9251	486.3954	-7.09	10.17
-15	384.2888	413.3808	442.9105	-7.04	6.67
-14	363.9047	391.2386	418.9563	-6.99	6.62
-13	344.7169	370.4072	396.4325	-6.94	6.56
-12	326.6497	350.8019	375.2461	-6.88	6.51
-11	309.6286	332.3441	355.3104	-6.83	6.46
-10	293.5903	314.9620	336.5448	-6.79	6.41
-9	278.4719	298.5822	318.3744	-6.74	6.22
-8	264.2156	283.1464	302.2294	-6.69	6.31
-7	250.7678	268.5936	286.5448	-6.64	6.26
-6	238.0783	254.8686	271.7603	-6.59	6.22
-5	226.1003	241.9200	257.8193	-6.54	6.17
-4	214.7903	229.6997	244.6593	-6.49	6.11
-3	204.1073	218.1630	232.2612	-6.44	6.07
-2	194.0135	207.2681	220.5495	-6.39	6.02
-1	184.4732	196.9759	209.4913	-6.35	5.97
0	175.4533	187.2500	199.0468	-6.30	5.93
1	166.8952	178.0255	189.1529	-6.25	5.88
2	158.8023	169.3067	179.8058	-6.20	5.84
3	151.1467	161.0633	170.9724	-6.16	5.80
4	143.9026	153.2667	162.6216	-6.11	5.75
5	137.0455	145.8905	154.7246	-6.06	5.71
6	130.5528	138.9097	147.2544	-6.02	5.67
7	124.4033	132.3011	140.1856	-5.97	5.62
8	118.5769	126.0429	133.4946	-5.92	5.58
9	113.0550	120.1146	127.1591	-5.88	5.54

5. ELECTRICAL DATA

T [°C]	Rmin [KΩ]	Rnom [KΩ]	Rmax [KΩ]	DR(MIN)%	DR(MAX)%
	107.8202	114.4973	121.1586	-5.83	5.50
11	102.8560	109.1728	115.4734	-5.79	5.46
12	98.1470	104.1246	110.0855	-5.74	5.41
13	93.6787	99.3367	104.9778	-5.70	5.37
14	89.4378	94.7946	100.1342	-5.65	5.33
15	85.4114	90.4842	95.5398	-5.61	5.29
16	81.5875	86.3926	91.1805	-5.56	5.25
17	77.9551	82.5076	87.0430	-5.52	5.21
18	74.5034	78.8177	83.1150	-5.47	5.17
19	71.2227	75.3122	79.3848	-5.43	5.13
	68.1036	71.9808	75.8414	-5.39	5.09
21	65.1373	68.8141	72.4746	-5.34	5.05
22	62.3155	65.8032	69.2746	-5.30	5.01
23	59.6306	62.9395	66.2324	-5.26	4.97
24	57.0752	60.2152	63.3395	-5.21	4.93
25	54.6424	57.6227	60.5877	-5.17	4.89
26	52.3258	55.1551	57.9695	-5.13	4.85
27	50.1192	52.8058	55.4778	-5.09	4.82
28	48.0168	50.5684	53.1058	-5.05	4.78
29	46.0133	48.4371	50.8472	-5.00	4.74
	44.1034	46.4046	48.6960	-4.96	4.71
31	42.2825	44.4711	46.6466	-4.92	4.66
32	40.5458	42.6261	44.6937	-4.88	4.63
33	38.8891	40.8668	42.8323	-4.84	4.59
34	37.3084	39.1890	41.0576	-4.80	4.55
35	35.7998	37.5883	39.3653	-4.76	4.51
36	34.3596	36.0609	37.7511	-4.72	4.48
37	32.9844	34.6030	36.2109	-4.68	4.44
38	31.6710	33.2113	34.7412	-4.64	4.40
39	30.4164	31.8823	33.3383	-4.60	4.37
	29.2176	30.6130	31.9988	-4.56	4.33
41	28.0718	29.4004	30.7197	-4.52	4.29
42	26.9765	28.2417	29.4979	-4.48	4.26
43	25.9293	27.1342	28.3306	-4.44	4.22
44	24.9277	26.0755	27.2150	-4.40	4.19
45	23.9697	25.0632	26.1488	-4.36	4.15
46	23.0530	24.0950	25.1293	-4.32	4.12
47	22.1757	23.1688	24.1545	-4.29	4.08
48	21.3360	22.2826	23.2221	-4.25	4.05
49	20.5321	21.4345	22.3301	-4.21	4.01
	19.7623	20.6226	21.4766	-4.17	3.98
51	19.0261	19.8468	20.6612	-4.14	3.94
52	18.3211	19.1040	19.8808	-4.10	3.91

5. ELECTRICAL DATA

T [°C]	Rmin [KΩ]	Rnom [KΩ]	Rmax [KΩ]	DR(MIN)%	DR(MAX)%
53	17.6458	18.3926	19.1338	-4.06	3.87
54	16.9986	17.7113	18.4185	-4.02	3.84
55	16.3784	17.0537	17.7335	-3.96	3.83
56	15.7839	16.4332	17.0774	-3.95	3.77
57	15.2139	15.8338	16.4488	-3.92	3.74
58	14.6673	15.2592	15.8464	-3.88	3.71
59	14.1430	14.7083	15.2690	-3.84	3.67
60	13.6400	14.1799	14.7154	-3.81	3.64
61	13.1573	13.6730	14.1846	-3.77	3.61
62	12.6941	13.1868	13.6756	-3.74	3.57
63	12.2494	12.7202	13.1872	-3.70	3.54
64	11.8224	12.2723	12.7186	-3.67	3.51
65	11.4124	11.8424	12.2690	-3.63	3.48
66	11.0185	11.4295	11.8373	-3.60	3.45
67	10.6401	11.0331	11.4230	-3.56	3.41
68	10.2765	10.6522	11.0251	-3.53	3.38
69	9.9271	10.2863	10.6429	-3.49	3.35
70	9.5912	9.9348	10.2756	-3.46	3.32
71	9.2682	9.5968	9.9231	-3.42	3.29
72	8.9576	9.2720	9.5841	-3.39	3.26
73	8.6589	8.9597	9.2583	-3.36	3.23
74	8.3716	8.6594	8.9451	-3.32	3.19
75	8.0951	8.3705	8.6440	-3.29	3.16
76	7.8290	8.0926	8.3544	-3.26	3.13
77	7.5730	7.8252	8.0758	-3.22	3.10
78	7.3264	7.5679	7.8078	-3.19	3.07
79	7.0891	7.3202	7.5499	-3.16	3.04
80	6.8605	7.0818	7.3018	-3.12	3.01
81	6.6403	6.8522	7.0629	-3.09	2.98
82	6.4282	6.6311	6.8329	-3.06	2.95
83	6.2239	6.4182	6.6115	-3.03	2.92
84	6.0269	6.2131	6.3982	-3.00	2.89
85	5.8371	6.0154	6.1928	-2.96	2.86
86	5.6542	5.8249	5.9949	-2.93	2.84
87	5.4777	5.6413	5.8042	-2.90	2.81
88	5.3076	5.4644	5.6205	-2.87	2.78
89	5.1435	5.2937	5.4433	-2.84	2.75
90	4.9853	5.1292	5.2726	-2.81	2.72
91	4.8326	4.9705	5.1079	-2.77	2.69
92	4.6852	4.8174	4.9492	-2.74	2.66
93	4.5430	4.6697	4.7960	-2.71	2.63
94	4.4058	4.5272	4.6483	-2.68	2.61
95	4.2733	4.3896	4.5058	-2.65	2.58

5. ELECTRICAL DATA

T [°C]	Rmin [KΩ]	Rnom [KΩ]	Rmax [KΩ]	DR(MIN)%	DR(MAX)%
96	4.1453	4.2568	4.3683	-2.62	2.55
97	4.0218	4.1287	4.2355	-2.59	2.52
98	3.9024	4.0049	4.1074	-2.56	2.50
99	3.7872	3.8854	3.9837	-2.53	2.47
100	3.6758	3.7700	3.8643	-2.50	2.44
101	3.5661	3.6585	3.7512	-2.53	2.47
102	3.4601	3.5509	3.6419	-2.56	2.50
103	3.3577	3.4468	3.5362	-2.59	2.53
104	3.2588	3.3463	3.4341	-2.61	2.56
105	3.1632	3.2491	3.3353	-2.64	2.58
106	3.0708	3.1551	3.2398	-2.67	2.61
107	2.9816	3.0643	3.1475	-2.70	2.64
108	2.8953	2.9765	3.0582	-2.73	2.67
109	2.8118	2.8915	2.9717	-2.76	2.70
110	2.7311	2.8093	2.8881	-2.78	2.73
111	2.6531	2.7299	2.8072	-2.81	2.75
112	2.5776	2.6530	2.7289	-2.84	2.78
113	2.5046	2.5785	2.6531	-2.87	2.81
114	2.4340	2.5065	2.5798	-2.89	2.84
115	2.3656	2.4368	2.5087	-2.92	2.87
116	2.2995	2.3693	2.4400	-2.95	2.90
117	2.2354	2.3040	2.3733	-2.98	2.92
118	2.1734	2.2407	2.3088	-3.00	2.95
119	2.1134	2.1795	2.2463	-3.03	2.97
120	2.0553	2.1201	2.1858	-3.06	3.01
121	1.9991	2.0626	2.1271	-3.08	3.03
122	1.9446	2.0070	2.0702	-3.11	3.05
123	1.8918	1.9530	2.0151	-3.13	3.08
124	1.8406	1.9007	1.9617	-3.16	3.11
125	1.7911	1.8500	1.9099	-3.18	3.14
126	1.7430	1.8009	1.8597	-3.22	3.16
127	1.6965	1.7533	1.8110	-3.24	3.19
128	1.6514	1.7071	1.7638	-3.26	3.21
129	1.6076	1.6623	1.7180	-3.29	3.24
130	1.5652	1.6189	1.6736	-3.32	3.27

5. ELECTRICAL DATA

($R_0=15K \pm 2\%$;

$B0/100=3450K \pm 2\%$)

T [°C]	Rmin [K Ω]	Rnom [K Ω]	Rmax [K Ω]	DR(MIN)%	DR(MAX)%
-30	60.78	64.77	68.99	-6.16	6.12
-29	57.75	61.36	65.16	-5.88	5.83
-28	54.89	58.15	61.58	-5.61	5.57
-27	52.19	55.14	58.23	-5.35	5.31
-26	49.63	52.30	55.08	-5.11	5.05
-25	47.21	49.62	52.13	-4.86	4.81
-24	44.92	47.10	49.37	-4.63	4.60
-23	42.76	44.73	46.78	-4.40	4.38
-22	40.71	42.49	44.34	-4.19	4.17
-21	38.77	40.38	42.05	-3.99	3.97
-20	36.93	38.39	39.90	-3.80	3.78
-19	35.18	36.51	37.87	-3.64	3.59
-18	33.53	34.74	35.97	-3.48	3.42
-17	31.96	33.06	34.17	-3.33	3.25
-16	30.48	31.47	32.49	-3.15	3.14
-15	29.07	29.97	30.89	-3.00	2.98
-14	27.73	28.56	29.39	-2.91	2.82
-13	26.46	27.22	27.98	-2.79	2.72
-12	25.26	25.95	26.64	-2.66	2.59
-11	24.11	24.75	25.38	-2.59	2.48
-10	23.03	23.61	24.19	-2.46	2.40
-9	21.99	22.53	23.06	-2.40	2.30
-8	21.01	21.51	22.00	-2.32	2.23
-7	20.08	20.54	20.99	-2.24	2.14
-6	19.19	19.62	20.04	-2.19	2.10
-5	18.35	18.74	19.14	-2.08	2.09
-4	17.55	17.92	18.29	-2.06	2.02
-3	16.78	17.13	17.48	-2.04	2.00
-2	16.06	16.38	16.71	-1.95	1.97
-1	15.36	15.67	15.98	-1.98	1.94
0	14.70	15.00	15.29	-2.00	1.90
1	14.08	14.36	14.64	-1.95	1.91
2	13.48	13.75	14.02	-1.96	1.93
3	12.91	13.17	13.43	-1.97	1.94
4	12.36	12.62	12.87	-2.06	1.94
5	11.85	12.09	12.34	-1.99	2.03
6	11.35	11.59	11.83	-2.07	2.03
7	10.88	11.11	11.35	-2.07	2.11
8	10.43	10.66	10.89	-2.16	2.11
9	9.999	10.230	10.450	-2.26	2.11
10	9.590	9.816	10.040	-2.30	2.23

5. ELECTRICAL DATA

T [°C]	Rmin [K Ω]	Rnom [K Ω]	Rmax [K Ω]	DR(MIN)%	DR(MAX)%
11	9.199	9.422	9.647	-2.37	2.33
12	8.826	9.047	9.269	-2.44	2.40
13	8.470	8.689	8.910	-2.52	2.48
14	8.129	8.347	8.567	-2.61	2.57
15	7.804	8.021	8.240	-2.71	2.66
16	7.493	7.709	7.928	-2.80	2.76
17	7.196	7.412	7.630	-2.91	2.86
18	6.912	7.127	7.346	-3.02	2.98
19	6.640	6.855	7.074	-3.14	3.10
20	6.381	6.595	6.815	-3.24	3.23
21	6.132	6.347	6.567	-3.39	3.35
22	5.894	6.109	6.330	-3.52	3.49
23	5.667	5.882	6.103	-3.66	3.62
24	5.449	5.664	5.886	-3.80	3.77
25	5.240	5.456	5.678	-3.96	3.91
26	5.048	5.260	5.478	-4.03	3.98
27	4.864	5.072	5.286	-4.10	4.05
28	4.687	4.891	5.101	-4.17	4.12
29	4.517	4.717	4.924	-4.24	4.20
30	4.355	4.550	4.753	-4.29	4.27
31	4.198	4.390	4.589	-4.37	4.34
32	4.048	4.236	4.431	-4.44	4.40
33	3.904	4.089	4.280	-4.52	4.46
34	3.766	3.946	4.134	-4.56	4.55
35	3.663	3.810	3.994	-3.86	4.61
36	3.506	3.679	3.859	-4.70	4.66
37	3.383	3.552	3.729	-4.76	4.75
38	3.265	3.431	3.604	-4.84	4.80
39	3.152	3.314	3.484	-4.89	4.88
40	3.043	3.202	3.368	-4.97	4.93
41	2.938	3.094	3.257	-5.04	5.00
42	2.838	2.990	3.149	-5.08	5.05
43	2.741	2.890	3.046	-5.16	5.12
44	2.648	2.793	2.946	-5.19	5.19
45	2.558	2.701	2.850	-5.29	5.23
46	2.472	2.611	2.758	-5.32	5.33
47	2.389	2.525	2.669	-5.39	5.40
48	2.309	2.443	2.583	-5.49	5.42
49	2.232	2.363	2.500	-5.54	5.48
50	2.158	2.286	2.421	-5.60	5.58
51	2.087	2.212	2.344	-5.65	5.63
52	2.018	2.140	2.269	-5.70	5.69
53	1.952	2.072	2.198	-5.79	5.73

5. ELECTRICAL DATA

T [°C]	Rmin [K Ω]	Rnom [K Ω]	Rmax [K Ω]	DR(MIN)%	DR(MAX)%
54	1.888	2.005	2.129	-5.84	5.82
55	1.827	1.941	2.062	-5.87	5.87
56	1.767	1.880	1.998	-6.01	5.91
57	1.710	1.820	1.936	-6.04	5.99
58	1.655	1.763	1.876	-6.13	6.02
59	1.602	1.707	1.818	-6.15	6.11
60	1.551	1.654	1.762	-6.23	6.13
61	1.502	1.602	1.709	-6.24	6.26
62	1.452	1.553	1.657	-6.50	6.28
63	1.409	1.505	1.606	-6.38	6.29
64	1.364	1.458	1.558	-6.45	6.42
65	1.322	1.413	1.511	-6.44	6.49
66	1.280	1.370	1.466	-6.57	6.55
67	1.241	1.328	1.422	-6.55	6.61
68	1.202	1.288	1.379	-6.68	6.60
69	1.165	1.249	1.339	-6.73	6.72
70	1.129	1.211	1.299	-6.77	6.77
71	1.095	1.175	1.261	-6.81	6.82
72	1.061	1.140	1.224	-6.93	6.86
73	1.029	1.106	1.188	-6.96	6.90
74	0.9977	1.073	1.153	-7.02	6.94
75	0.9676	1.041	1.120	-7.05	7.05
76	0.9385	1.011	1.088	-7.17	7.08
77	0.9104	0.9810	1.056	-7.20	7.10
78	0.8833	0.9523	1.026	-7.25	7.18
79	0.8570	0.9246	0.9971	-7.31	7.27
80	0.8316	0.8977	0.9687	-7.36	7.33
81	0.8071	0.8717	0.9412	-7.41	7.38
82	0.7834	0.8466	0.9146	-7.47	7.43
83	0.7604	0.8223	0.8888	-7.53	7.48
84	0.7382	0.7987	0.8639	-7.57	7.55
85	0.7167	0.7759	0.8397	-7.63	7.60
86	0.6958	0.7537	0.8161	-7.68	7.65
87	0.6755	0.7322	0.7933	-7.74	7.70
88	0.6560	0.7114	0.7712	-7.79	7.75
89	0.6371	0.6913	0.7498	-7.84	7.80
90	0.6188	0.6718	0.7291	-7.89	7.86
91	0.6011	0.6530	0.7051	-7.95	7.39
92	0.5840	0.6348	0.6897	-8.00	7.96
93	0.5674	0.6171	0.6709	-8.05	8.02
94	0.5514	0.6000	0.6527	-8.10	8.07
95	0.5359	0.5835	0.6350	-8.16	8.11
96	0.5209	0.5675	0.6179	-8.21	8.16

5. ELECTRICAL DATA

T [°C]	Rmin [K Ω]	Rnom [K Ω]	Rmax [K Ω]	DR(MIN)%	DR(MAX)%
97	0.5064	0.5519	0.6014	-8.24	8.23
98	0.4923	0.5369	0.5853	-8.31	8.27
99	0.4787	0.5224	0.5698	-8.37	8.32
100	0.4655	0.5083	0.5547	-8.42	8.36
101	0.4528	0.4946	0.5401	-8.45	8.42
102	0.4404	0.4814	0.5259	-8.52	8.46
103	0.4284	0.4685	0.5121	-8.56	8.51
104	0.4168	0.4561	0.4988	-8.62	8.56
105	0.4056	0.4440	0.4859	-8.65	8.62
106	0.3947	0.4323	0.4733	-8.70	8.66
107	0.3841	0.4210	0.4611	-8.76	8.70
108	0.3739	0.4100	0.4493	-8.80	8.75
109	0.3640	0.3993	0.4379	-8.84	8.81
110	0.3544	0.3890	0.4267	-8.89	8.84
111	0.3450	0.3789	0.4159	-8.95	8.90
112	0.3360	0.3692	0.4055	-8.99	8.95
113	0.3272	0.3597	0.3953	-9.04	9.01
114	0.3187	0.3505	0.3854	-9.07	9.06
115	0.3104	0.3416	0.3758	-9.13	9.10
116	0.3024	0.3330	0.3665	-9.19	9.14
117	0.2947	0.3246	0.3574	-9.21	9.18
118	0.2871	0.3164	0.3468	-9.26	8.77
119	0.2798	0.3085	0.3401	-9.30	9.29
120	0.2727	0.3008	0.33	-9.34	9.34

دما پویا

6. CONTROL MODE

6-1 Indoor control mode

1. Major general technical parameters

- 1 Remote receiver distance: 8 m.
- 2 Remote receiver angle: Less than 80 degrees.
- 3 Temperature control accuracy: $\pm 1^{\circ}\text{C}$.
- 4 Time error: Less than 1%.

2. Functions of the controller

Control function

2.1 Emergency switch

Press the emergency button can realize the starting or closing Machine, starting up according to the automatic mode of operation (invalid for duct type air-conditioner)

- ① Press this button to turn ON the unit, the conditioner will be run in auto mode, and press it again to turn off.
- ② When the machine is turned OFF, by press and hold the emergency switch for 5 seconds, with 3 beeps, the indoor unit would turn to emergency run. In such station, machine would be forced to turn to cooling operation with the indoor fan speed being set at high speed, the flaps sweeping and the air conditioner's operation is irrelevant with room temperatures.
- ③ If a remote signal has been received during the emergency run, the machine will operate upon the command of such a remote signal.

2.2 Operator-machine communication

Air conditioning and remote controller is provided with a temperature sensor. The remote controller on the temperature sensor to detect the default settings of room temperature at room temperature. If the indoor control unit for long time have not received remote control signal, will automatically switch to the air conditioner body temperature sensor.

2.3 Timer function

1. Timer on: When set to start in a time by the remote controller, the air conditioner starts in the timer on condition. When the set time is up, the air conditioner will turn on and operates in the preset conditions after receiving a signal from the remote controller. If the air conditioner has not received a signal from the remote controller when the set time is up, it will automatically start and operate in the preset conditions.

2. Timer off: When set to stop in a set time by the remote controller, the air conditioner

6. CONTROL MODE

will start in the timer off condition. When the set time is up, the air conditioner will turn off after receiving a signal from the remote controller. If the air conditioner has not received a signal from the remote controller when the set time is up, it will turn off automatically.

3. Neither the turning on nor turning off operation will cancel the timer function.

2.4 Sleep

1. In the heating, cooling or dehumidifying mode, press the "Sleep" button on the remote controller to start or cancel the sleep function in turn, and at the same time the sleep icon on the display screen will be on or off accordingly.

2. In the heating mode, the set temperature will decrease automatically after the sleep function is started.

3. In the cooling mode, the set temperature will rise automatically after the sleep function is started.

4. In default, the setting is to cancel the sleep function. Turning off the unit will also cancel the sleep function.

2.5 High efficient run function

In Cool, Dehumidification, Fan mode, press the "HIGH POWER" to enter the refrigeration mode, set the temperature automatically adjust to 18°C; the Fan speed is powerful speed; frequency of high frequency operation.

In the heating mode, powerful function is invalid for H1 wireless remote controller.

2.6 mute function (only for H1 wireless remote controller)

In the indoor machine operation mode, You may turn on mute function and turn off mute function by mute key, The air conditioner will run by mute fan speed in mute mode

2.7 prevent cooling wind mode

In the heating-run, to prevent the indoor fan from blowing cold air, the indoor fan will stop or run slowly until the coil is warmth.

2.8 blow waste heating and waste cooling function

The heating mode, remote shutdown, such as indoor heat exchanger temperature is

6. CONTROL MODE

higher, the wind blowing out opportunities continue to run the waste heat.

Cool and dehumidification mode , after the compressor close, indoor machine will continue to set the speed of operation for a period of time.

2.9 automatically model

This model does not automatically model function, emergency button cannot set the automatic mode of operation, can use the emergency switch shutdown, remote setting the automatic mode of indoor machine with remote signal. (emergency button only for cassette type)

2.10 Dehumidifying method:

Remote control setting dehumidifying mode, indoor machine forced to run at low speed (high power key or a strong bond also maintain a low wind speed) , the outdoor machine according to the refrigeration mode operation.

2.11 Self Recovery of Power Break

When the power supply is recovered after break, all preset are still effective and the air-conditioner can run according to the original setting.

How to set/cancel

It can be set by wire remote controller YXE-C01U/YXE-C02U.

Details see Internal control parameter adjustment.

2.12 FAULT CODE

The fault code can be showed by LED on the indoor panel.

2.13 Filter clean

Filer clean led will light up when air filter is clogged with dust.

How to reset:

- ① Press Emergency switch;
- ② Press high power button for 5s;
- ③ By wire remote controller YXE-C01U/YXE-C02U, press cancel button for 3s.

6-2 Outdoor mode control

Control function

6. CONTROL MODE

1. Cooling Anti-freeze Protection

To prevent indoor air conditioner evaporator temperature is too low, the indoor coil sensor for real time detection of evaporator. If the indoor coil temperature is too low, the compressor will protect.

2. Overload Protection

Air can heat exchanger temperature sensor for monitoring, when the sensor when the temperature is too high, the compressor will be automatic protection

3. Exhaust temperature protection

To prevent deterioration due to high exhaust temperature of compressor, the machine will realize the real-time detection of the temperature of exhaust gas. If the temperature is too high compressor automatic protection

4. Operation Mode

Air conditioning mode is the operation mode set by users through remote controller, four modes are available: cooling, heating, dehumidification, as well as fan mode.

5. Four-way Valve Control

Four-way valve of the outdoor machine shuts down when cooling and defrosting but starts when heating. During the heating process, the four way valve to stop working for a period of time after compressor disconnect.

6. Start-up Protection:

To prevent compressor from restart frequently in the condition that system pressure has not been completely balanced, it can't be restarted within 3 minutes.

7. Pressure Protection:

6. CONTROL MODE

When the pressure increases to a preset value, the pressure switch will automatically protect. Compressor will stop and report the fault code protection.



7. TROUBLE SHOOTING

Trouble guide

When the air conditioner failure occurs, the fault code will displays on control board , wire remote controller or display panel.

HOW TO CHECK FAULT CODES

INDOOR UNIT

1.WALL MOUNTED TYPE

For Free-match series

Run the air-conditioner by wireless remote controller , continue pressing “SLEEP ”button for 4 times, fault codes will flashing rapidly on the LCD . If no fault , display "00".

“ER”shows indoor display panel communication fault with indoor unit control board .

For VRF series

Fault codes flash rapidly on the LCD.

2.FLOOR STANDING TYPE

L5B (indoor box code)series

In the case of no button-locked,continue pressing “CLOCK”button for 8 times ,fault codes will display on the LCD for 10 seconds,automatically disappears after 10seconds.

Continue pressing “SLEEP”button of wireless remote controller for 8 times ,fault codes will display on the LCD for 10 seconds,automatically disappears after 10seconds.

“ER”shows indoor display panel Communication fault with indoor unit control board

L5C(indoor box code) series

Continue pressing “SLEEP”button of wireless remote controller for4 times ,fault codes will display on the LCD for 10 seconds,automatically disappears after 10seconds.

3.DUCT , CASSETTE,CEILING&FLOOR TYPE

(1) ERROR CODES INDICATED BY WIRE REMOTE CONTROLLER(see fig. below)

MOEDL:YXC-A01U(E)

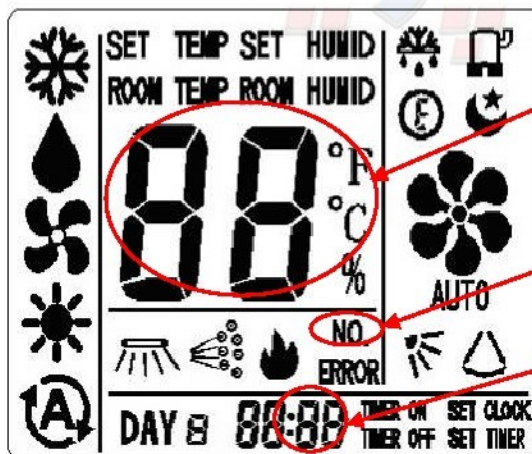

When display“FE” ,shows that the wire controller can't receive the signals of indoor unit control board ,please check

When failure occurs, this lamp light ON.

This number shows ERROR CODE.

7. TROUBLE SHOOTING

MOEDL:YXE-C01U

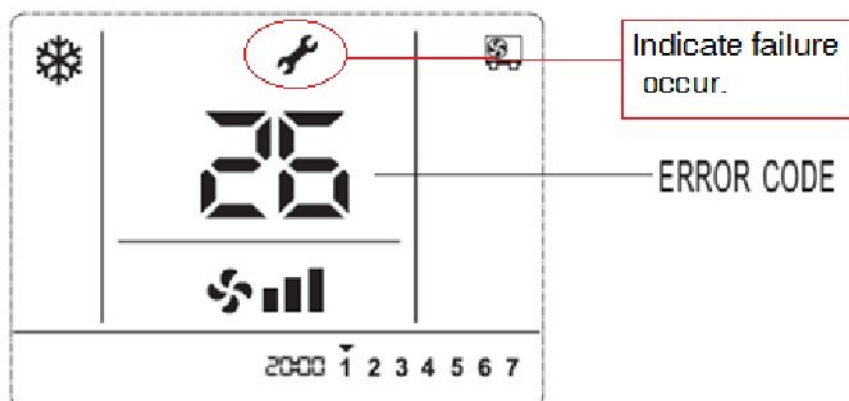

When the airconditioner is malfunction,  will display on the LCD, and error codes will appear and blink.

FIG.2 ERROR CODE DISPLAY ON WIRE REMOT CONTROLLER

(2) CHECK ERROR CODES BY DISPLAY PANEL(CASSETTE type and CEILING & FLOOR type)

Display by lamp indicator

Lamp RUN(LED2 ,red) and Lamp DEFROST (LED5 ,green) flashing, Lamp RUN display fault code ten digit number, lamp DEFROST display fault code single digit number (as shown fig. below).

For example, fault code 36: led RUN & defrost flash 3 times at the same time, and led DEFROST continue flash 3 times, reports No. 36 fault.

دما پویا

7. TROUBLE SHOOTING

CASSETTE TYPE

Display Panel-12K,18K

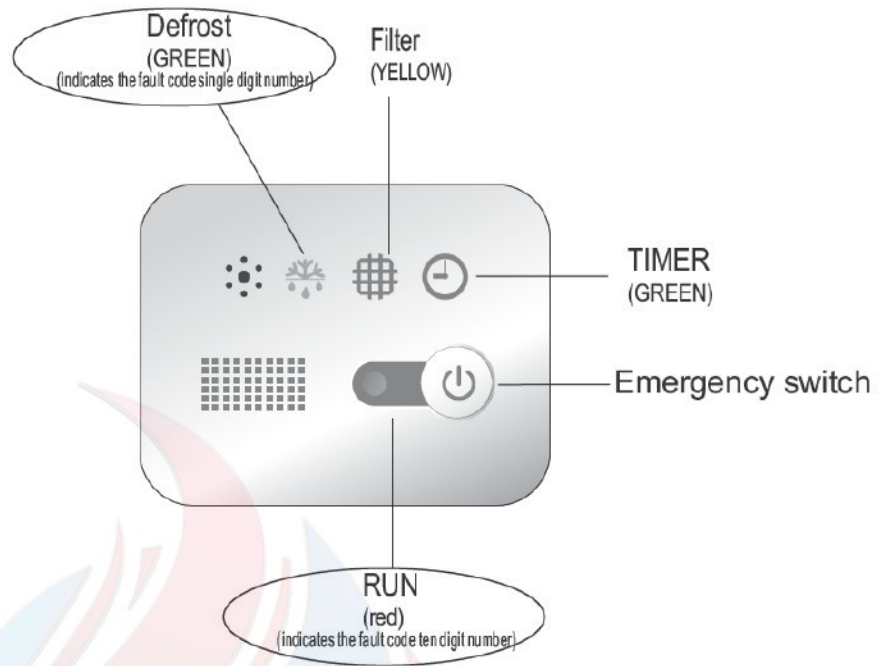

Display Panel-24K,36K,48K

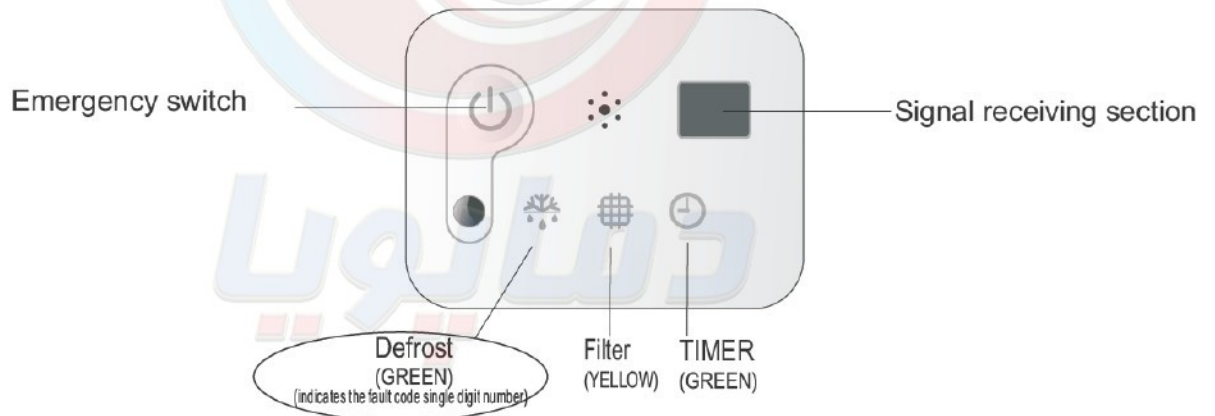

7. TROUBLE SHOOTING

CEILING & FLOOR TYPE Display Panel

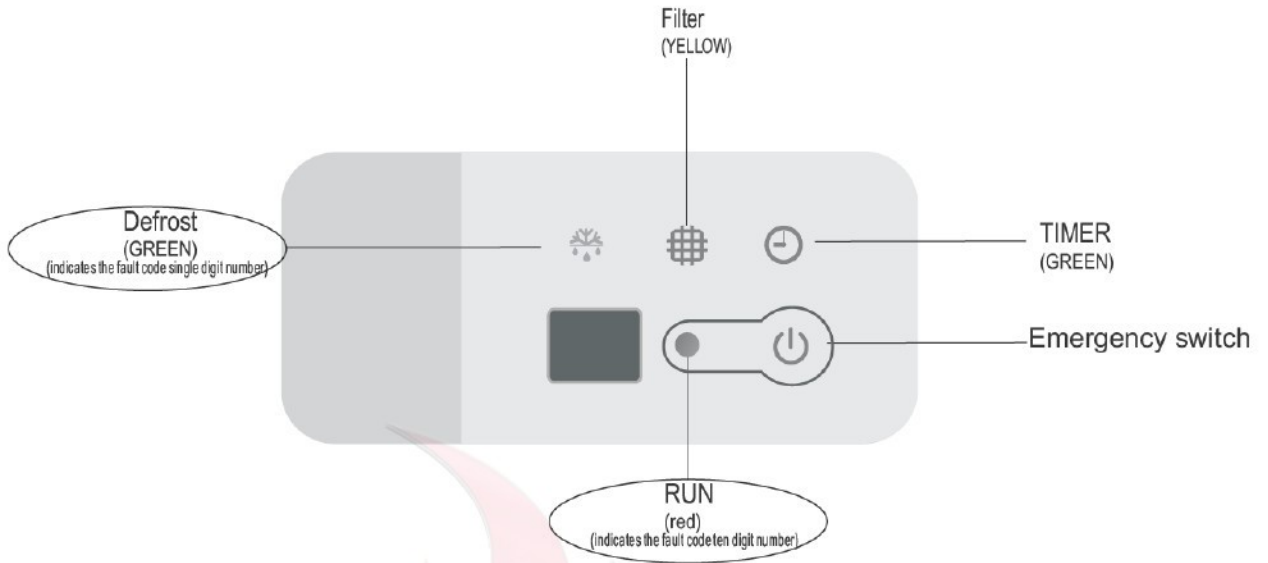

LED FLASH CONTROL: flash 300mS(T1), off 300mS(T2), after 2000mS(T3) fault code repeat displays. (as shown below)

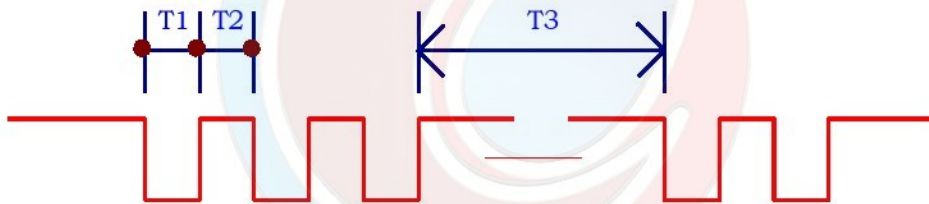
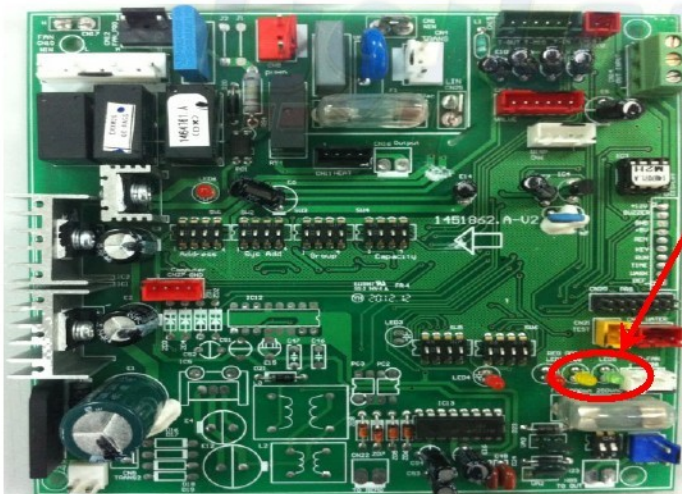

Fig.2 LED FLASH CONTROL

3. Duct type indoor units of VRF---FAULT CODE DISPLAY BY INDOOR BOARD



LED2 and LED5 are failure indicate lamps,
LED2 (RED) indicate fault code ten digit number, LED5 (GREEN) indicate single digit number code

7. TROUBLE SHOOTING

2. OUTDOOR UNIT FAULT CODE DISPLAY

(1) ON/OFF UNITARY TYPE (with outdoor control box)

Fault code display by indicate lamps of outdoor control board flash.

The times that the lamp flashes equal to fault code.

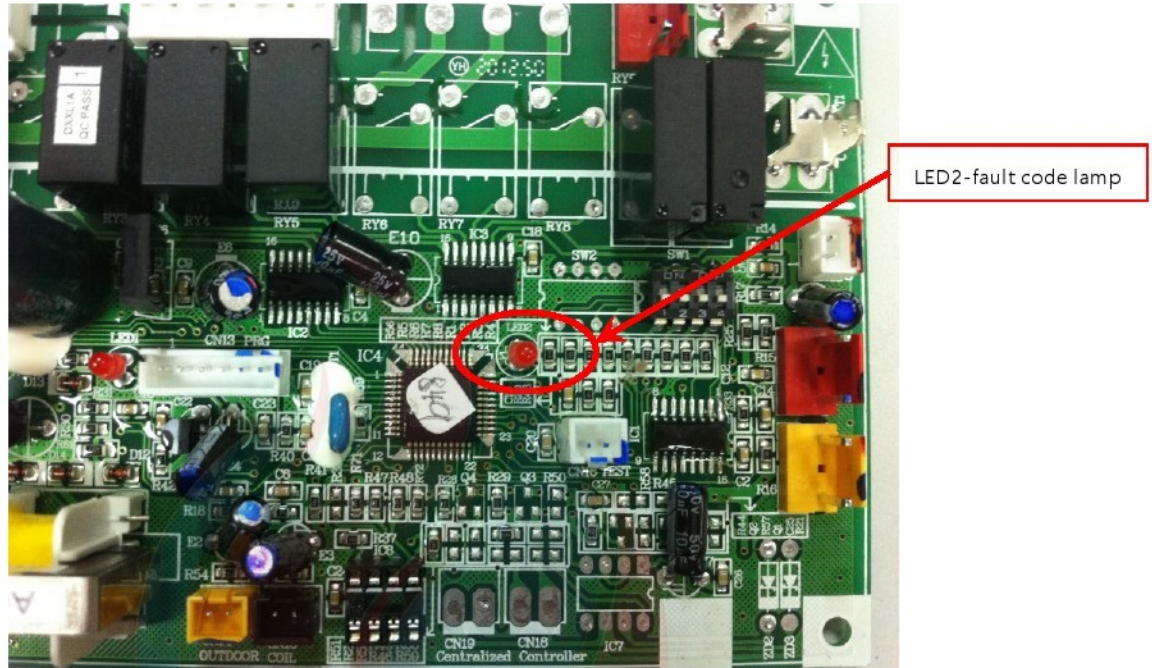

LED FLASH CONTROL: flash 300mS(T1), off 300mS(T2), after 900mS(T3) fault code repeat displays.

(as shown below)

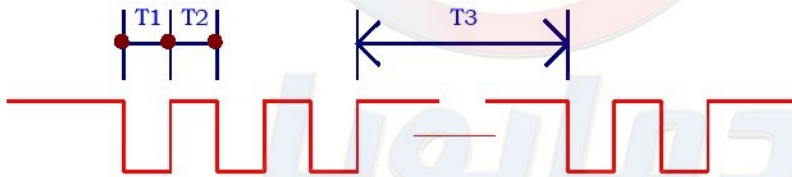

(2) INVERTER UNITARY AIR CONDITIONER , MULTI-SPLIT TYPE AIR CONDITONER&VRF:

Fault code will display on digital tube board.

7. TROUBLE SHOOTING

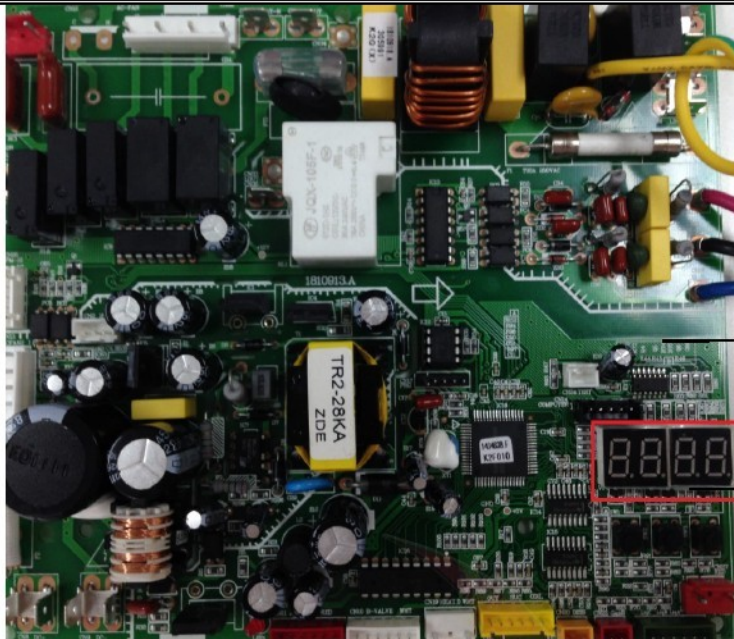

Outdoor Control Board

Digital Tube

FOR INVERTER UNITARY AIR CONDITONER&VRF

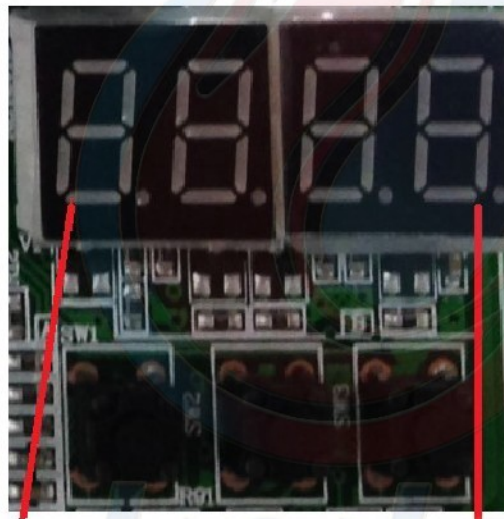

E shows failure occur

Display ERROR Code

* VRF:

Indoor unit can indicate both indoor failure and outdoor failure ,but outdoor only indicate outdoor's.

FOR MULTI-SPLIT TYPE

Error code display on digital tube board directly.

7. TROUBLE SHOOTING

3. Fault code display (Driver Board)

The lamp of driver board flash shows failure occur.

Or, fault code can be check on digital tube board .



7. TROUBLE SHOOTING

The following is the fault code table of outdoor.

sheet 1 Outdoor Error Code

Fault code	Fault Description	Possible Reason of Abnormality	How to Deal With	REMARKS
1	Outdoor ambient temperature sensor fault	<ol style="list-style-type: none"> 1.The outdoor ambient temperature sensor connect loose; 2.The outdoor ambient temperature sensor is failure; 3.The sampling circuit is failure 	<ol style="list-style-type: none"> 1.Reconnect the outdoor ambient temperature sensor; 2.Replace the outdoor ambient temperature sensor components; 3.Replace the outdoor control board components. 	
2	Outdoor coil temperature sensor fault	<ol style="list-style-type: none"> 1.The outdoor ambient temperature sensor connect loose; 2.The outdoor ambient temperature sensor is failure; 3.The sampling circuit is failure 	<ol style="list-style-type: none"> 1.Reconnect the outdoor ambient temperature sensor; 2.Replace the outdoor ambient temperature sensor components; 3.Replace the outdoor control board components. 	
3	The unit over-current turn off fault	<ol style="list-style-type: none"> 1.Control board current sampling circuit is failure; 2.The current is over high because of the supply voltage is too low 3.The compressor is blocked 4. Overload in cooling mode 5.Overload in heating mode 	<ol style="list-style-type: none"> 1. Replace the electrical control board components; 2. Normally protection 3. Replace the compressor 4. Please see the Note 3 5. Please see the Note 4 	
4	EEProm Data error	<ol style="list-style-type: none"> 1.EE components is failure; 2.EE components control circuit failure; 3.EE components insert incorrect 	<ol style="list-style-type: none"> 1.Replace the EE components; 2.Replace the outdoor control board components; 3.Reassembly the EE components. 	
5	Cooling freezing protection(the indoor coil temperature is too low) or heating overload(indoor coil temperature is too high)	<ol style="list-style-type: none"> 1.The indoor unit can not blow air normally; 2.The room temperature is too low in cooling mode or the room temperature is too high in heating; 3.The filter is dirty; 4.The duct resistance of the duct 5.The setting fan speed is too low 6. The indoor unit has been installed without standard 	<ol style="list-style-type: none"> 1.Check the indoor fan, indoor fan motor and evaporator whether normally; 2. Normally protection 3.Clean the filter; 4.Check the volume control valve, duct length etc; 5.Set the speed with high speed; 6.Reinstall the indoor unit refer to the user manual to change the distance between the indoor unit and the wall or ceiling. 	

7. TROUBLE SHOOTING

Fault code	Fault Description	Possible Reason of Abnormality	How to Deal With	REMARKS
6	Motor blockage protection	<ol style="list-style-type: none"> 1.Outdoor ambient temperature sensor fault; 2. Outdoor coil temperature sensor fault; 3.Outdoor control board fault. 	<ol style="list-style-type: none"> 1.Replace outdoor ambient temperature sensor; 2.Replace outdoor coil temperature sensor; 3.Replace Outdoor control board. 	Applied to ON/OFF air-conditioners with 2 control boards
7	The communication fault between the indoor unit and outdoor unit	<ol style="list-style-type: none"> 1.The connection cable connect wrong between the indoor unit and outdoor unit; 2.The communication cable connect loose; 3.The communication cable is fault; 4.The indoor control board is fault; 5.The outdoor control board is fault; 6.Communication circuit fuse open; 7.The specification of communication cable is incorrect. 	<ol style="list-style-type: none"> 1.Reconnect the connection cable refer to the wiring diagram; 2.Reconnect the communication cable; 3.Replace the communication cable; 4.Replace the indoor control board; 5.Replace the outdoor control board; 6.Check the communication circuit, adjust the DIP switch and the short-circuit fuse. 7.Choose suitable communication cable refer to the user manual 	
8	Phase current imbalance	<ol style="list-style-type: none"> 1.The supply voltage fluctuates more than 4%; 2.The compressor power cord connect loose; 3.The AC contactor is fault; 4.The compressor motor fault. 	<ol style="list-style-type: none"> 1.Normally protection; 2.Reconnect the wire refer to the wiring diagram; 3.Replace the AC contactor; 4.Replace the compressor. 	Application of three-phase power supply models
9	U phase current fault	<ol style="list-style-type: none"> 1.Compressor U phase power cord is fault or connect wrong; 2.Outdoor control board is fault; 3.The Compressor is fault 	<ol style="list-style-type: none"> 1.Replace the U phase power cord or reconnect the U phase power cord refer to the wiring diagram; 2.Replace the outdoor control board; 3.Replace the compressor. 	Application of three-phase power supply models
10	V phase current fault	<ol style="list-style-type: none"> 1.Compressor V phase power cord is fault or connect wrong; 2.The outdoor control board is fault; 3.The compressor is fault 	<ol style="list-style-type: none"> 1.Replace the V phase power cord or reconnect the V phase power cord refer to the wiring diagram; 2.Replace the outdoor control board; 3.Replace the compressor. 	Application of three-phase power supply models

7. TROUBLE SHOOTING

Fault code	Fault Description	Possible Reason of Abnormality	How to Deal With	REMARKS
11	phase wrong failure	<ol style="list-style-type: none"> 1.Three-phase power is abnormal; 2.The outdoor wiring connect wrong; 3. The outdoor control board is failure 	<ol style="list-style-type: none"> 1.Normally protection, please check the supply power 2.Check the wiring connection refer to the wiring diagram; 3.Replace the outdoor control board 	Application of three-phase power supply models
12	voltage absent phase	<ol style="list-style-type: none"> 1.Three-phase power is abnormal; 2.The outdoor wiring connect wrong; 3.The outdoor control board is failure. 	<ol style="list-style-type: none"> 1. Normally protection 2. Check the wiring connection refer to the wiring diagram; 3. Replace the outdoor control board 	Application of three-phase power supply models
13	Compressor overheat protector device	<ol style="list-style-type: none"> 1. The wiring of the overload protector connect loose. 2. The overload protector is failure . 3. The refrigerant is not enough; 4. The installation pipe is too long than normal, but not add the enough refrigerant; 5. The expansion valve is failure; 6. The outdoor control board is failure 	<ol style="list-style-type: none"> 1. Reconnect the wiring of the overload protector; 2. Replace the overload protector; 3. Check the welding point of the unit to confirm whether it is leakage, and then recharge the refrigerant; 4. Add the refrigerant; 5. Replace expansion valve; 6. Replace the outdoor control board. 	
14	the high pressure switch operate or the unit turn off for high pressure protection	<ol style="list-style-type: none"> 1.The wiring of the high pressure protector connect loose; 2.The high pressure protector is failure; 3.The outdoor control board is abnormal; 4. Overload in cooling; 5. Overload in heating. 	<ol style="list-style-type: none"> 1.Reconnect the wiring the high pressure protector; 2. Replace the high pressure protector; 3. Replace the outdoor control board; 4. Please refer to the Note 3; 5. Please refer to the Note 4. 	Applied to models with high pressure switch or pressure sensor
15	the low pressure switch protection or the unit turn off for low pressure protection	<ol style="list-style-type: none"> 1. The low pressure switch is failure; 2.The wiring of the low pressure switch connect loose; 3.The refrigerant is not enough; 4.The expansion valve failure in heating mode; 5.The outdoor control board is abnormal. 	<ol style="list-style-type: none"> 1. Reconnect the wiring of the low pressure switch; 2. Replace the low pressure switch; 3.Check the welding point to confirm whether the unit is leakage, and then add some refrigerant; 4. Replace the expansion valve; 5. Replace the outdoor control board. 	Applied to models with low pressure switch or pressure sensor
16	overload protection in cooling mode	System overload	Please refer to the Note 3.	
17	Discharge temperature sensor fault	<ol style="list-style-type: none"> 1.The wiring of the discharge temperature sensor connect loose; 2.The discharge temperature sensor is 	<ol style="list-style-type: none"> 1.Reconnect the wiring of the discharge temperature sensor; 2.Replace the discharge temperature 	

7. TROUBLE SHOOTING

Fault code	Fault Description	Possible Reason of Abnormality	How to Deal With	REMARKS
		failure; 3.The sampling circuit is abnormal.	sensor; 3.Replace the outdoor control board.	
18	AC voltage is abnormal	1.The AC voltage>275V or <160V. 2.The AC voltage of sampling circuit on the driver board is abnormally	1. Normally protection , please check the supply power; 2. Replace the driver board.	MUTI-SPLIT TYPE ONLY
19	Suction temperature sensor fault	1.The wiring of the suction temperature sensor connect loose; 2. The suction temperature sensor is failure; 3. The sampling circuit is abnormally	1.Reconnect the wiring of the suction temperature sensor; 2.Replace the suction temperature sensor; 3.Replace the outdoor control board.	
20	The temperature sensor for the inlet tube of the condenser fault	1.The wiring of the temperature sensor for the inlet tube connect loose; 2.The temperature sensor for the inlet tube is failure; 3.The sampling circuit is abnormally	1.Reconnect the wiring of the temperature sensor for the inlet tube of the condenser; 2.Replace the temperature sensor for the inlet tube of the condenser; 3.Replace the outdoor control board.	
21	The outlet tube of the condenser temperature sensor fault	1.The wiring of the temperature sensor for the outlet tube connect loose; 2.The temperature sensor for the outlet tube is failure; 3.The sampling circuit is abnormally	1. Reconnect the wiring of the temperature sensor for the outlet tube of the condenser. 2.Replace the temperature sensor for the outlet tube of the condenser; 3.Replace the outdoor control board.	
22	The defrosting sensor fault	1.The wiring of the defrosting sensor connect loose; 2.The defrosting sensor is failure; 3.The sampling circuit is abnormally	1. Reconnect the wiring of the defrosting sensor; 2. Replace the defrosting sensor; 3. Replace the outdoor control board.	
23	Expansion valve A tube(thin) sensor fault	1. The wiring of the sensor for the expansion valve A(thin tube) connect loose; 2.The sensor for the expansion A(thin tube) is failure; 3. The sampling circuit is abnormally	1. Reconnect the wiring of the sensor for the expansion valve A(thin tube); 2. Replace the sensor for the expansion valve A(thin tube); 3. Replace the outdoor control board.	FOR MUTI-SPLIT &Inverter unitary types
24	Expansion valve B (thin)tube sensor fault	1. The wiring of the sensor for the expansion valve B (thin tube) connect loose; 2.The sensor for the expansion valve B(thin tube) is failure; 3.The sampling circuit is abnormally	1.Reconnect the wiring of the sensor for the expansion valve B(thin tube); 2.Replace the sensor for the expansion valve B(thin tube); 3. Replace the outdoor control board.	FOR MUTI-SPLIT outdoor
25	Expansion valve C (thin)tube sensor fault	1. The wiring of the sensor for the expansion valve C(thin tube) connect loose; 2.The sensor of the expansion valve C (thin tube) is failure; 3.The sampling circuit is abnormally	1. Reconnect the wiring of the sensor for the expansion valve C(thin tube); 2. Replace the sensor for the expansion valve C(thin tube); 3. Replace the outdoor control board.	FOR MUTI-SPLIT outdoor

7. TROUBLE SHOOTING

Fault code	Fault Description	Possible Reason of Abnormality	How to Deal With	REMARKS
26	Expansion valve D (thin)tube sensor fault	<ol style="list-style-type: none"> 1.The wiring of the sensor for the expansion valve D(thin tube) connect loose; 2.The sensor of the expansion valve D (thin tube) is failure; 3.The sampling circuit is abnormally 	<ol style="list-style-type: none"> 1. Reconnect the wiring of the sensor for the expansion valve D(thin tube); 2. Replace the sensor for the expansion valve D(thin tube); 3. Replace the outdoor control board. 	FOR MUTI-SPLIT outdoor
27	Expansion valve A (thick tube) sensor fault	<ol style="list-style-type: none"> 1. The wiring of the sensor for the expansion valve A(thick tube) connect loose; 2.The sensor of the expansion valve A (thick tube) is failure; 3.The sampling circuit is abnormally 	<ol style="list-style-type: none"> 1. Reconnect the wiring of the sensor for the expansion valve A(thick tube); 2. Replace the sensor for the expansion valve A(thick tube); 3. Replace the outdoor control board. 	FOR MUTI-SPLIT &inverter unitary types
28	Expansion valve B (thick tube) sensor fault	<ol style="list-style-type: none"> 1. The wiring of the sensor for the expansion valve B(thick tube) connect loose; 2.The sensor of the expansion valve B (thick tube) is failure; 3. The sampling circuit is abnormally 	<ol style="list-style-type: none"> 1. Reconnect the wiring of the sensor for the expansion valve B(thick tube); 2. Replace the sensor for the expansion valve B(thick tube); 3. Replace the outdoor control board. 	FOR MUTI-SPLIT outdoor
29	Expansion valve C (thick tube) sensor fault	<ol style="list-style-type: none"> 1. The wiring of the sensor for the expansion valve B(thick tube) connect loose; 2.The sensor of the expansion valve C (thick tube) is failure; 3. The sampling circuit is abnormally 	<ol style="list-style-type: none"> 1. Reconnect the wiring of the sensor for the expansion valve B(thick tube); 2. Replace the sensor for the expansion valve C(thick tube); 3. Replace the outdoor control board. 	FOR MUTI-SPLIT outdoor
30	Expansion valve D (thick tube) sensor fault	<ol style="list-style-type: none"> 1. The wiring of the sensor for the expansion valve B(thick tube) connect loose; 2.The sensor of the expansion valve D (thick tube) is failure; 3. The sampling circuit is abnormally 	<ol style="list-style-type: none"> 1. Reconnect the wiring of the sensor for the expansion valve B(thick tube); 2. Replace the sensor for the expansion valve D(thick tube); 3. Replace the outdoor control board. 	FOR MUTI-SPLIT outdoor
31	The discharge pressure is too high	<ol style="list-style-type: none"> 1. Overload in cooling; 2. Overload in heating 	<ol style="list-style-type: none"> 1. Overload in cooling; 2. Overload in heating 	VRF outdoor
32	The suction pressure is too low fault	<ol style="list-style-type: none"> 1.The refrigerate is not enough for the unit; 2.The expansion valve is failure in heating mode; 3.The outdoor ambient temperature is too low in heating mode 	<ol style="list-style-type: none"> 1.Check the welding point to confirm whether it exist the leakage point, and then add some refrigerate; 2. Replace the expansion valve; 3.The unit should operate within allowable temperature range. 	VRF outdoor
40	high pressure and low pressure imbalance before compressor start	<ol style="list-style-type: none"> 1.The wiring of the high/low pressure sensor connect loose; 2.The wiring of the bypass valve connect loose; 3. High/low pressure sensor is failure; 4.Bypass coil is failure. 5.Bypass valve is failure. 6.The capillary that connect with bypass 	<ol style="list-style-type: none"> 1.Reconnect the wiring of high/low pressure sensor . 2..Reconnect the wiring of the bypass valve ; 3.Replace pressure sensor. 4.Replace bypass valve coil. 5.Replace bypass coil. 6.Check whether blockage occur. 	VRF outdoor

7. TROUBLE SHOOTING

Fault code	Fault Description	Possible Reason of Abnormality	How to Deal With	REMARKS
		valve blockage 7.The outdoor control board is fault;	7.Replace outdoor control board.	
42	the voltage sensor fault	1.The wiring of the voltage sensor connect wrong or loose; 2. The voltage sensor is failure; 3. The sampling circuit of the voltage sensor is failure.	1. Reconnect the wiring of the current sensor; 2. Replace the voltage sensor; 3. Replace the outdoor control board.	
43	High Pressure sensor fault	1.The wiring of the high-pressure pressure sensor connect loose; 2.The high-pressure pressure sensor is failure 3.The sampling circuit of the high-pressure pressure sensor is failure	1.Reconnect the wiring of the high-pressure pressure sensor; 2.Replace the high-pressure pressure sensor; 3.Replace the outdoor control board.	VRF
44	Low Pressure sensor fault	1.The wiring of the low-pressure pressure sensor connect loose; 2.The low-pressure pressure sensor is failure 3.The sampling circuit of the low-pressure pressure sensor is failure.	1.Reconnect the wiring of the low-pressure pressure sensor; 2.Replace the low-pressure pressure sensor; 3.Replace the outdoor control board.	
45	IPM fault	There are many reasons for this failure, If you need further analysis, fault code of the driver board is needed by watching the driver board fault led. Analysis can be further to know why and how to operate. Specific see table 5, table 6.	See attached "analysis of the driving board fault".	Applied for INVERTER type
46	IPM and control board communication fault	1.The cable between the control board and the driver board connect loose; 2.The cable between the control board and the driver board is failure; 3.The driver board is failure 4.The control board is failure	1.Reconnect the cable between the control board and the driver board; 2.Replace the communication cable between the control board and the driver board; 3.Replace the driver board; 4.Replace the control board.	Applied for Inverter Unitary type&Free-Match
46-1	IPM and control board communication fault	1.The cable between the control board and the driver board connect loose; 2.The cable between the control board and the driver board is failure; 3.The driver board is failure 4.The control board is failure	1.Reconnect the cable between the control board and the driver board; 2.Replace the communication cable between the control board and the driver board; 3.Replace the driver board;	Applied for VRF

7. TROUBLE SHOOTING

Fault code	Fault Description	Possible Reason of Abnormality	How to Deal With	REMARKS
			4. Replace the control board.	
46-2	Replenish gas board and control board communication fault	<ol style="list-style-type: none"> 1. The cable between the control board and replenish gas board connect loose; 2. The cable between the control board and replenish gas board is failure; 3. The replenish gas board is failure 4. The control board is failure 	<ol style="list-style-type: none"> 1. Reconnect the cable between the control board and the replenish gas board; 2. Replace the communication cable between the control board and the replenish gas board; 3. Replace the replenish gas board ; 4. Replace the control board. 	Applied for VRF
47	Discharge temperature too high fault	<ol style="list-style-type: none"> 1. The refrigerant of the unit is not enough; 2. The refrigerant of the unit is not enough due to add the length of the installation pipe 3. Throttling service is failure; 4. The outdoor ambient temperature is too high 	<ol style="list-style-type: none"> 1. Check the welding point to confirm whether the unit has exist leakage point, and then add some refrigerant. 2. Add some refrigerant refer to the installation user manual; 3. Replace the throttling service (such as capillary, expansion valve) 4. Normally protection. 	
48	the outdoor DC fan motor fault (upper fan motor)	<ol style="list-style-type: none"> 1. The wiring of the up DC fan motor connect loose; 2. The cord of the up DC fan motor is failure; 3. The up DC fan motor is failure; 4. The drive circuit of the up DC fan motor is failure; 5. The outdoor fan has been blocked. 	<ol style="list-style-type: none"> 1. Reconnect the wiring of the up DC fan motor; 2. Replace the up DC fan motor; 3. Replace the up DC fan motor; 4. Replace the driver board of the fan motor; 5. Check the outdoor fan and ensure the outdoor fan can run normally. 	
48-1	the outdoor upper DC fan motor Locked rotor fault	<ol style="list-style-type: none"> 1. The fan motor motor rotation blockage; 2. The fan motor is failure; 3. The outdoor control board is failure; 4. The driver board is failure; 	<ol style="list-style-type: none"> 1. Remove the fan motor locked-rotor sundry, recover motor operating conditions; 2. Replace the upper DC fan motor; 3. Replace the outdoor control board ; 4. Replace the driver board . 	VRF
48-2	the outdoor upper DC fan motor stall fault	<ol style="list-style-type: none"> 1. The fan motor is failure; 2. The outdoor control board is failure; 3. The driver board is failure; 	<ol style="list-style-type: none"> 1. Replace the upper fan motor; 2. Replace the outdoor control board ; 3. Replace the driver board . 	VRF

7. TROUBLE SHOOTING

Fault code	Fault Description	Possible Reason of Abnormality	How to Deal With	REMARKS
49	the outdoor DC fan motor fault (down fan motor)	<ol style="list-style-type: none"> 1.The wiring of the down DC fan motor connect loose; 2.The cord of the down DC fan motor is failure; 3. The down DC fan motor is failure; 4. The drive circuit of the down DCfan motor is failure; 5. The outdoor fan has been blocked. 	<ol style="list-style-type: none"> 1. Reconnect the wiring of the down DC fan motor; 2. Replace the down DC fan motor; 3.Replace the down DC fan motor; 4.Replace the driver board of the fan motor; 5. Check the outdoor fan and ensurethe outdoor fan can run normally. 	
49-1	the outdoor lower DC fan motor Locked rotor fault	<ol style="list-style-type: none"> 1.The fan motor motor rotation blockage; 2. The fan motor is failure; 3.The outdoor control board is failure; 4. The driver board is failure; 	<ol style="list-style-type: none"> 1. Remove the fan motor locked-rotor sundry, recover motor operating conditions; 2. Replace the lower DC fan motor; 3. Replace the outdoor control board ; 4 .Replace the driver board . 	VRF
49-2	he outdoor lower DC fan motor stall fault	<ol style="list-style-type: none"> 1. The fan motor is failure; 2.The outdoor control board is failure; 3. The driver board is failure; 	<ol style="list-style-type: none"> 1. Replace thelower fan motor; 2. Replace the outdoor control board ; 3 .Replace the driver board . 	VRF
50	Expansion valve E temperature sensor fault	<ol style="list-style-type: none"> 1. The wiring of the sensor connect loose; 2.The sensor of the expansion valve E is failure; 3. The sampling circuit is abnormally 	<ol style="list-style-type: none"> 1. Reconnect the wiring of the sensor; 2. Replace the sensor for the expansion valve E; 3. Replace the outdoor control board. 	FOR Branch Box
63	Current sensor fault	<ol style="list-style-type: none"> 1. The wiring of the current sensor connect loose; 2.The current sensor is failure; 3. The sampling circuit is abnormally 	<ol style="list-style-type: none"> 1. Reconnect the wiring of the sensor; 2. Replace the current sensor; 3. Replace the outdoor control board. 	Application of three-phase power supply ON/OFF unitary models
66	Radiator temperature sensor fault	<ol style="list-style-type: none"> 1. The sensor connect is loose; 2.The current sensor is failure; 3. The sampling circuit is abnormally 	<ol style="list-style-type: none"> 1. Reconnect the wiring ; 2. Replace the temperature sensor; 3. Replace the outdoor control board. 	
67	Radiator temperature protect			reserved
76	Water temperature sensor 1 fault	<ol style="list-style-type: none"> 1.The wiring of the temperature sensor connect loose; 2.The temperature sensor is failure; 3.The sampling circuit is abnormally 	<ol style="list-style-type: none"> 1.Reconnect the wiring of the temperature sensor; 2.Replace the temperature sensor; 3.Replace the control board. 	For Heat pump water heater&water chiller air conditioner

7. TROUBLE SHOOTING

Fault code	Fault Description	Possible Reason of Abnormality	How to Deal With	REMARKS
77	Water temperature sensor 2 fault	<ol style="list-style-type: none"> 1.The wiring of the temperature sensor connect loose; 2.The temperature sensor is failure; 3.The sampling circuit is abnormally 	<ol style="list-style-type: none"> 1.Reconnect the wiring of the temperature sensor; 2.Replace the temperature sensor; 3.Replace the control board. 	For Heat pump water heater&water chiller air conditioner
91	The unit turn off due to the IPM board over heating fault	<ol style="list-style-type: none"> 1.The outdoor ambient is too high; 2. The speed of the out fan motor is too low if the fan motor is AC fan motor; 3.The outdoor unit has been installed without standard; 4.The supply power is too low. 	<ol style="list-style-type: none"> 1. Normally protection; 2. Check the fan capacitor, and replace the fan capacitor if it is failure; 3. Reinstalled the outdoor unit refer to the installation user manual; 4.Normally protection. 	
92	the ratio of the discharge pressure than the suction pressure is too large	<ol style="list-style-type: none"> 1.The filter of the expansion valve is dirty; 2. The difference between the indoor room temperature and the outdoor ambient temperature is too large; 3. The refrigerant of the unit is not enough; 4.;The expansion is failure or the capillary is failure 5. The outdoor ambient temperature is too low in heating mode 	<ol style="list-style-type: none"> 1. Replace the expansion valve; 2. Normally protection; 3.Check the welding point of the unit to confirm whether it exist leakage point, and then add some refrigerant; 4.Replace the expansion valve or the capillary; 5. Please let the unit operates within the allowable temperature range. 	VRF
93-1	The quantity of the indoor unit is more than the set.	<ol style="list-style-type: none"> 1.Indoor unit quantity set is incorrect; 2.New indoor unit is added in the system. 	Reset the number of the indoor units.	VRF
93-2	The quantity of the indoor unit is less than the set.	<ol style="list-style-type: none"> 1. Not all of the indoor units are power on; 2. The set quantity of the indoor unit is incorrect; 3.Add or remove some indoor units 	<ol style="list-style-type: none"> 1. Put all the indoor units power on; 2. Reset the quantity of the indoor units; 3. Reset the quantity of the indoor units 	VRF
94	outdoor address conflict	<ol style="list-style-type: none"> 1. Put all the indoor units power on; 2. Reset the quantity of the indoor units; 3. Reset the quantity of the indoor units 	Change the setting address of the outdoor unit	VRF
95	the refrigerant of the unit is excessive fault	The refrigerant of the unit is excessive	Discharge the refrigerant and charge the refrigerant refer to the rating label	VRF
96	the refrigerant of the unit is not enough fault	The refrigerant of the unit is not enough	Discharge the refrigerant and charge the refrigerant refer to the rating label	VRF
97	4-way valve commutation failure fault	<ol style="list-style-type: none"> 1.The wiring of the 4-way valve coil connect loose; 2.The 4-way valve coil is failure; 3.The 4-way valve is failure; 4.The driver board of the 4-way valve is failure 	<ol style="list-style-type: none"> 1. Reconnect the wiring of the 4-way valve; 2. Replace the 4-way valve coil; 3. Replace the 4-way valve; 4.Replace the driver board of the 4-way valve. 	FOR VRF&inverter unitary types

7. TROUBLE SHOOTING

The following is the fault code table of indoor.

Sheet 2 Indoor Error Code List

Fault code	Fault Description	Possible Reason of Abnormality	How to Deal With	REMARKS
31	The buttons of the front panel AD fault	<ol style="list-style-type: none"> 1. The buttons are failure; 2. The cable of the display board is failure; 3. The display board is failure; 4. The indoor control board is failure. 	<ol style="list-style-type: none"> 1. Replace the display board; 2. Replace the cable of the display board; 3. Replace the display board; 4. Replace the indoor control board. 	Only for MUTI-SPLIT 5009 FLOOR-STANDING UNIT
32	The front panel fault is not in place	<ol style="list-style-type: none"> 1. The front panel has been blocked; 2. The connection cable of the switch and the motor connect loose; 3. The switch is failure; 4. The motor of the front panel is ailure; 5. The indoor control board is failure. 	<ol style="list-style-type: none"> 1. Reassembly the front panel; 2. Reconnect the cable of the switch and panel motor. 3. Replace the switch; 4. Replace the motor of the front panel; 5. Replace the indoor control board. 	Only for MUTI-SPLIT 5009 FLOOR-STANDING UNIT
33	Room temperature sensor fault	<ol style="list-style-type: none"> 1. The cable of the indoor room temperature sensor connect loose; 2. The indoor room temperature sensor 	<ol style="list-style-type: none"> 1. Reconnect the cable of the indoor room temperature sensor; 2. Replace the indoor room temperature 	Only for MUTI-SPLIT

7. TROUBLE SHOOTING

Fault code	Fault Description	Possible Reason of Abnormality	How to Deal With	REMARKS
		is failure; 3. The sampling circuit is abnormal.	sensor; 3. Replace the indoor control board.	
34	Coil temperature sensor fault	1. The cable of the indoor coil temperature sensor connect loose; 2. The indoor coil temperature sensor is failure; 3. The sampling circuit is abnormal.	1. Reconnect the cable of the indoor room temperature sensor; 2. Replace the indoor room temperature sensor; 3. Replace the indoor control board.	Only for MUTI-SPLIT
35	Panel drive fault (two upper and lower panel position detection switch is not in accordance with the reservation timing action)	1. The front panel has been blocked; 2. The connection cable of the switch and the motor connect loose; 3. The switch is failure; 4. The motor of the front panel is failure; 5. The indoor control board is failure.	1. Reassembly the front panel; 2. Reconnect the cable of the switch and panel motor. 3. Replace the switch; 4. Replace the motor of the front panel; 5. Replace the indoor control board.	Only for MUTI-SPLIT 5009 FLOOR-STANDING UNIT
36	Communication between Indoor and outdoor fault	1. The connection cable between the indoor unit and the outdoor unit connect wrong; 2. The communication cable between the indoor unit and the outdoor unit connect loose or the cable between the indoor control board to terminal connect loose or the cable between the outdoor control board to the terminal connect loose; 3. The indoor control board is failure; 4. The outdoor control board is failure;	1. Reconnect the connection cable refer to the indoor and outdoor wiring diagram; 2. Reconnect the communication cable refer to the indoor and outdoor wiring diagram; 3. Replace the communication cable refer to the indoor and outdoor wiring diagram; 4. Replace the indoor control board; 5. Replace the outdoor control board.	Only for MUTI-SPLIT
37	Humidity sensor failure	1. The cable of the humidity sensor connect loose; 2. The humidity sensor is failure; 3. The indoor control board is failure.	1. Reconnect the cable of the humidity sensor; 2. Replace the humidity sensor; 3. Replace the indoor control board.	Only for MUTI-SPLIT
38	EEPROM Data error	1. EE components is failure; 2. The EE control circuit of the control board is failure; 3. The EE components has been inserted with opposite direction.	1. Replace the EE components; 2. Replace the control board; 3. Reinsert the EE components.	Only for MUTI-SPLIT
39	The indoor DC fan motor fault	1. The cable of the DC fan motor connect loose; 2. The indoor control board is failure; 3. The indoor fan motor is failure.	1. The cable of the DC fan motor connect loose; 2. The indoor control board is failure; 3. The indoor fan motor is failure.	Only for MUTI-SPLIT

7. TROUBLE SHOOTING

Fault code	Fault Description	Possible Reason of Abnormality	How to Deal With	REMARKS
40	The grill protection	<ol style="list-style-type: none"> 1.The grill has not been installed in right place; 2.The protection switch is failure; 3.The indoor control board is failure. 	<ol style="list-style-type: none"> 1. Adjust the grill and put it in right place; 2. Replace the switch components; 3. Replace the indoor control board. 	Only for MUTI-SPLIT
41	Zero check fault	Control board is failure.	Replace the indoor control board.	PG motor
51	Drainage protection	<ol style="list-style-type: none"> 1. The water level of the drain pan exceed safe level; 2. The cable of the water level switch connect loose; 3.The water level switch is failure; 4. The control board is failure. 	<ol style="list-style-type: none"> 1. Check whether there are something to block the drain hose or the height of the drain hose is too high; 1.2 Check the water pump and replace the water pump if the water pump is failure; 2. Reconnect the cable of the water level switch refer to the wiring diagram; 3. Replace the water level switch; 4. Replace the control board. 	
52	The grill protection	<ol style="list-style-type: none"> 1.The grill has not been installed in right place; 2.The protection switch is failure; 3. The control board is failure. 	<ol style="list-style-type: none"> 1. Adjust the grill and put it in right place; 2. Replace the switch components; 3. Replace the indoor control board. 	
53	The upper panel is not in place to protection	<ol style="list-style-type: none"> 1. The front panel has been blocked; 2. The cable of the switch and the motor connect loose; 3. The switch is failure; 4. The panel motor is failure; 5. The indoor control board is failure. 	<ol style="list-style-type: none"> 1. Reassembly the front panel; 2. Reconnect the cable of the switch and the panel motor; 3. Replace the switch components; 4. Replace the panel motor; 5. Replace the indoor control board. 	
54	The lower panel is not in place to protection	<ol style="list-style-type: none"> 1. The front panel has been blocked; 2. The cable of the switch and the motor connect loose; 3. The switch is failure; 4. The panel motor is failure; 5. The indoor control board is failure. 	<ol style="list-style-type: none"> 1. Reassembly the front panel; 2. Reconnect the cable of the switch and the panel motor; 3. Replace the switch components; 4. Replace the panel motor; 5. Replace the indoor control board. 	
55	Mode Conflict Fault	The user set the conflicting mode for more than two indoor units	Reset the operate mode for the indoor unit, for the one outdoor unit, the user should avoid to set the conflicting operate mode with the indoor units	ONLY FOR MUTI-SPLIT & VRF TYPES
56	Refrigeration freezing protection	<ol style="list-style-type: none"> 1. System refrigerant short. 2. Outdoor temperature is too low; 3. The indoor unit air out short circuit. 4. Indoor exchanger too much dust; 5. Indoor fan is failure or baffled; 6. Indoor fan motor 's rotating 	<ol style="list-style-type: none"> 1. Empty the refrigerant , air exhaust and recharge refrigerant; 2. Use the air-conditioner within the allowed temperature; 3. Adjust the installation place; 4. Clean the indoor heat changer; 	Only for VRF

7. TROUBLE SHOOTING

Fault code	Fault Description	Possible Reason of Abnormality	How to Deal With	REMARKS
		<p>Speed is too low;</p> <p>7. Indoor unit's air intake or air outlet is blocked;</p> <p>8. EEV's opening too small or capillary is blocked.</p>	<p>5. Check and make sure the indoor fan is OK ;</p> <p>6. Check and be sure the fan motor and capacitors are all OK;</p> <p>7. Remove the Remove the Occlusions;</p> <p>8. Check and repair EEV or capillary.</p>	
57	Overload in cooling mode	See note 3.	See note 3.	Only for VRF
58	Coil temperature sensor (liquid tube)fault	<p>1.The coil temperature sensor (liquid tube)connect loose;</p> <p>2.The coil temperature sensor(liquid tube) is failure;</p> <p>3.The control board is failure</p>	<p>1.Reconnect the coil temperature sensor;</p> <p>2.Replace the coil temperature sensor components;</p> <p>3.Replace the control board components.</p>	Only for heat pump water heater
59	Liquid tube temperature protect	<p>1.The resistance of temperature sensor is abnormal.</p> <p>2.Control board circuit is abnormal.</p> <p>3.Water temperature in tank is too high(over 70℃);</p> <p>4.No water in tank.</p>	<p>1.Change temperature sensor.</p> <p>2.Change Control board .</p> <p>3.Normally protection,should lower water temperature;</p> <p>4.Open fill pump to supply water;Check whether there is leakage occur.</p>	Only for heat pump water heater
60	water shortage protect	<p>1.Water shortage in tank;</p> <p>2.Water temperature sensor in tank is abnormal.</p> <p>3.Control board is abnormal.</p>	<p>1.Open fill pump to supply water;Check whether there is leakage occur.</p> <p>2.Change temperature sensor.</p> <p>3.Change Control board .</p>	Only for heat pump water heater
61	Indoor address repeat fault	Two or more two indoor units has set with the same address.	Reset the address of the indoor unit and it should avoid the address repeat.	For VRF
62	Remote address repeat fault	When the same indoor unit with more than one wiring controller, a number of the address of the wiring controller is same	Reset the address of the wiring controller and avoid the address of the wiring controller repeat.	For VRF

7. TROUBLE SHOOTING

Fault code	Fault Description	Possible Reason of Abnormality	How to Deal With	REMARKS
64	Communication between Indoor & Outdoor unit Fault	<ol style="list-style-type: none"> 1. The connection cable between the indoor unit and the outdoor unit connect wrong; 2. The communication cable connect loose; 3. The communication cable between the indoor unit and the outdoor unit is failure or the cable between the indoor control board to terminal is failure or the cable between the outdoor control board to the terminal is failure; 4. The indoor control board is failure; 5. The outdoor control board is failure. 	<ol style="list-style-type: none"> 1. Reconnect the connection cable refer to the indoor and outdoor wiring diagram; 2. Reconnect the communication cable refer to the indoor and outdoor wiring diagram; 3. Replace the communication cable refer to the indoor and outdoor wiring diagram; 4. Replace the indoor control board; 5. Replace the outdoor control board. 	
65	The indoor unit can not receive the sign of the wiring controller	<ol style="list-style-type: none"> 1. The cable of the wiring controller connect loose; 2. The cable of the wiring controller is failure; 3. The wiring controller is failure; 4. The indoor control board is failure. 	<ol style="list-style-type: none"> 1. Reconnect the cable of the wiring controller; 2. Replace the cable of the wiring controller; 3. Replace the wiring controller; 4. Replace the indoor control board. 	For VRF
71	Indoor unit zero check fault	<ol style="list-style-type: none"> 1. The motor wire is loosen; 2. The motor connect is open; 3. The motor is failure; 4. Control board is failure. 5. Indoor fan is baffled. 	<ol style="list-style-type: none"> 1. Replace the motor wire and make sure the wire connect is well; 2. Replace the motor wire; 3. Change the motor; 4. Change the indoor control board; 5. Check and elimination of fan motor rotation. 	Only for VRF indoor unit
72	Indoor fan motor fault	<ol style="list-style-type: none"> 1. The cable of the indoor fan motor connect loose; 2. The cable of the indoor fan motor is failure; 3. The indoor fan motor is failure; 4. The indoor control board is failure 	<ol style="list-style-type: none"> 1. Reconnect the cable of the fan motor; 2. Replace the cable of the fan motor; 3. Replace the fan motor; 4. Replace the indoor control board; 5. Check the indoor fan and ensure the indoor fan can run normally. 	
73	Indoor EEPROM Data 1 fault	<ol style="list-style-type: none"> 1. Indoor EE components is failure; 2. The control circuit of the EE components is failure; 3. The EE components has been inserted with opposite direction 	<ol style="list-style-type: none"> 1. Replace the EE components; 2. Replace the indoor control board; 3. Reassembly the EE components of the indoor control board 	
74	Indoor EEPROM Data 2 error	EE in MCU is failure, the unit can run, but the function user has set is ineffective.	Replace EE data in MCU.	

7. TROUBLE SHOOTING

Fault code	Fault Description	Possible Reason of Abnormality	How to Deal With	REMARKS
75	Trial run not pass	Reserved	Reserved	Reserved
78	The indoor unit has not been registered	The indoor unit has not been registered	Register indoor unit.	
80	Panel key fault	<ol style="list-style-type: none"> 1. The button is failure; 2. The cable of the display board is failure; 3. The display board is failure; 4. The indoor control board is failure 	<ol style="list-style-type: none"> 1. Replace the display board; 2. Replace the cable of the display board; 3. Replace the display board; 4. Replace the indoor control board. 	
81	Indoor ambient Temperature Sensor Fault	<ol style="list-style-type: none"> 1. The cable of the room temperature sensor connect loose; 2. The room temperature sensor is failure; 3. The sampling circuit is abnormally 	<ol style="list-style-type: none"> 1.Reconnect the cable of the room temperature sensor; 2. Replace the room temperature sensor; 3. Replace the indoor control board. 	
82	Evaporator Inlet Temperature Sensor Fault	<ol style="list-style-type: none"> 1.The cable of the coil temperature sensor of the evaporator is failure; 2. The coil temperature sensor of the evaporator is failure; 3. The sampling circuit is abnormally 	<ol style="list-style-type: none"> 1.The cable of the coil temperature sensor of the evaporator is failure; 2. The coil temperature sensor of the evaporator is failure; 3. The sampling circuit is abnormally 	
83	Evaporator Middle Temperature Sensor Fault	<ol style="list-style-type: none"> 1.The cable of the coil temperature sensor of the evaporator is failure; 2. The coil temperature sensor of the evaporator is failure; 3. The sampling circuit is abnormally 	<ol style="list-style-type: none"> 1. Reconnect the cable of the coil temperature sensor of the evaporator; 2. Replace the coil temperature sensor of the evaporator; 3. Replace the indoor control board. 	
84	Evaporator outlet Temperature Sensor Fault	<ol style="list-style-type: none"> 1.The cable of the coil temperature sensor of the evaporator is failure; 2. The coil temperature sensor of the evaporator is failure; 3. The sampling circuit is abnormally 	<ol style="list-style-type: none"> 1. Reconnect the cable of the coil temperature sensor of the evaporator; 2. Replace the coil temperature sensor of the evaporator; 3. Replace the indoor control board. 	
85	Wiring Remote Controller Sensor Fault	<ol style="list-style-type: none"> 1. The temperature sensor of the wiring controller is failure; 2. The sampling circuit of the wiring controller is failure 	<ol style="list-style-type: none"> 1. Replace the wiring controller; 2. Replace the wiring controller 	
86	Air outlet temperature sensor fault	<ol style="list-style-type: none"> 1. The cable of the temperature sensor of the air outlet connect loose; 2. The temperature sensor of the air outlet is failure; 3. The sampling circuit is abnormally 	<ol style="list-style-type: none"> 1.Reconnect the cable of the temperature sensor of the air outlet; 2. Replace the temperature sensor of the air outlet; 3. Replace the indoor control board. 	
87	The inlet of water side entrance temperature sensor fault	<ol style="list-style-type: none"> 1. The cable of the temperature sensor of the inlet of water side is failure; 2. The temperature sensor of the inlet of water side is failure; 3.The sampling circuit is abnormally 	<ol style="list-style-type: none"> 1. Reconnect the cable of the temperature sensor of the inlet of water side; 2. Replace the temperature sensor of the inlet of water side; 3. Replace the indoor control board. 	

7. TROUBLE SHOOTING

Fault code	Fault Description	Possible Reason of Abnormality	How to Deal With	REMARKS
88	The outlet of water side entrance temperature sensor fault	<ol style="list-style-type: none"> 1. The cable of the temperature sensor of the outlet of water side is failure; 2. The temperature sensor of the outlet of water side is failure; 3. The sampling circuit is abnormally 	<ol style="list-style-type: none"> 1. Reconnect the cable of the temperature sensor of the outlet of water side; 2. Replace the temperature sensor of the outlet of water side; 3. Replace the indoor control board. 	
89	Humidity sensor failure	<ol style="list-style-type: none"> 1. The humidity sensor is failure; 2. The indoor control board is abnormally 	<ol style="list-style-type: none"> 1. Replace the humidity sensor components; 2. Replace the indoor control board. 	
98	Water module DIP switch function select fault	<ol style="list-style-type: none"> 1. DIP switch select failure; 2. DIP is abnormal; 3. Control board is abnormal. 	<ol style="list-style-type: none"> 1. Replace DIP switch; 2. Change DIP switch; 3. Change control board. 	
F0 (240)	Wire remote controller EEPROM failure	<ol style="list-style-type: none"> 1. EEPROM of wire remote controller is abnormal; 2. Wire remote controller control board is abnormal. 	Change wire remote controller .	
F1 (241)	Wire remote controller temperature sensor failure	<ol style="list-style-type: none"> 1. Temperature sensor of wire remote controller is abnormal; 2. Wire remote controller control board is abnormal. 	Change wire remote controller .	
F2 (242)	Wire remote controller clock IC failure	Wire remote controller control board is abnormal.	Change wire remote controller .	
F3 (243)	Wire remote controller humidity sensor failure	<ol style="list-style-type: none"> 1. Temperature /humidity sensor of wire remote controller is abnormal; 2. Wire remote controller control board is abnormal. 	Change wire remote controller .	
FE(254)	Communication between main control board & Wiring remote controller Fault (display on wiring remote controller)	<ol style="list-style-type: none"> 1. The wiring between the wiring controller to the indoor control board connect loose; 2. The sequence of the wiring between the wiring controller to the indoor control board is wrong; 3. The wiring between the wiring controller to the indoor control board is failure; 4. The wiring controller is failure; 5. The indoor control board is abnormally 	<ol style="list-style-type: none"> 1. Reconnect the wiring between the wiring controller to the indoor control board; 2. Replace the wiring between the wiring controller to the indoor control board; 3. Replace the wiring between the wiring controller to the indoor control board; 4. Replace the wiring controller; 5. Replace the indoor control board 	

7. TROUBLE SHOOTING

Fault code	Fault Description	Possible Reason of Abnormality	How to Deal With	REMARKS
ER	Communication between main control board & display board Fault (displays on display board)	1.The wiring between the display board to the indoor control board connect loose; 2.The sequence of the wiring between the display board to the indoor control board is wrong; 3.The wiring between the display board to the indoor control board is failure; 4. The display board is failure; 5. The indoor control board is failure.	1. Reconnect the between the display board to the indoor control board; 2. Replace the wiring between the display board to the indoor control board; 3. Replace the wiring between the display board to the indoor control board; 4. Replace the display board; 5. Replace the indoor control board.	

NOTE 1:

If the indoor unit can not turn on or the indoor unit turn off itself after 30s, at the same time the unit do not display the error code, please check the fire and the socket of the control board.

Note 2:

If the indoor unit display the 75,76,77,78 error code after you turn on the unit, please check the TEST seat of the indoor control board or the TEST detection circuit whether exists short circuit.

Note 3:Overload in cooling mode

overload in cooling mode		
sr.	The root cause	Corrective measure
1	The refrigerant is excessive	Discharge the refrigerant, and recharge the refrigerant refer to the rating label
2	The outdoor ambient temperature is too high	Please use within allowable temperature range
3	The air outlet and air inlet of the outdoor unit is short-circuit	Adjust the installation of the outdoor unit refer to the user manual
4	The outdoor heat exchanger is dirty, such as condenser	Clean the heat exchanger of the outdoor unit, such as condenser
5	The speed of the outdoor fan motor is too low	Check the outdoor fan motor and fan capacitor
6	The outdoor fan is broken or the outdoor fan is blocked	Check the outdoor fan
7	The air inlet and outlet has been blocked	Remove the blocked thing
8	The expansion valve or the capillary is failure	Replace the expansion valve or the capillary

Note 4:Over load in heating mode

Overload in heating mode		
sr.	The root cause	Corrective measure

7. TROUBLE SHOOTING

1	The refrigerant is excessive	Discharge the refrigerant, and recharge the refrigerant refer to the rating label
2	The indoor ambient temperature is too high	Please use within allowable temperature range
3	The air outlet and air inlet of the indoor unit is short-circuit	Adjust the installation of the indoor unit refer to the user manual
4	The indoor filter is dirty	Clean the indoor filter
5	The speed of the indoor fan motor is too low	Check the indoor fan motor and fan capacitor
6	The indoor fan is broken or the outdoor fan is blocked	Check the indoor fan
7	The air inlet and outlet has been blocked	Remove the blocked thing
8	The expansion valve or the capillary is failure	Replace the expansion valve or the capillary

The following is the fault code table of driver board.

Analysis of the Driving Board Fault

Driver board fault codes trouble shooting (*Except Free-match 20K&16K DUAL TYPES*), details see sheet 5.

I. Driver fault code display by indicate lamps of driver board flashing. The times that the lamp flashes equal to fault code. Flashing Intervals for a period of time again. Indicator light off when no fault.

For example, fault code 3: Indicator light flash 3 times and Flashing Intervals for a period of time again, reports No. 3 fault.

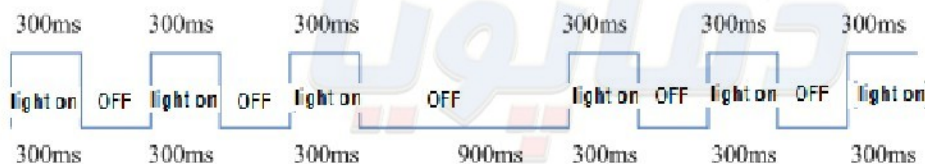

Sheet 5 Driver Error Code -----Except 20K&16 Dual types

Fault code	Fault Description	Possible Reason of Abnormality	How to Deal With
1	Q axis current detection, step out of failure	1, compressor wire connect not well; 2, Bad driver board components; 3, Compressor start load is too large; 4, Compressor demagnetization;	1, Check compressor wire; 2, Change driver board ; 3, Turn on the machine after pressure balance again;

7. TROUBLE SHOOTING

Fault code	Fault Description	Possible Reason of Abnormality	How to Deal With
		5,Compressor oil shortage, serious wear of crankshaft.; 6.The compressor insulation fault	4, Change Compressor; 5, Change the Compressor; 6, Change the Compressor.
2	Phase current detection, out of step	1. Compressor voltage default phase; 2. Bad driver board components; 3. The compressor insulation fault	1,Check compressor wire connection; 2, Change the driver board; 3, Change the Compressor.
3	Initialization, phase current imbalance	Bad driver board components.	Change driver board .
4	Speed estimation, step out of failure	1,Bad driver board components; 2,Compressor shaft clamping; 3.The compressor insulation fault.	1, Change driver board ; 2, Change the Compressor ; 3, Change the Compressor .
5	IPM FO output fault	1.System overload or current overload. 2,Driver board fault; 3, Compressor oil shortage,serious wear of crankshaft; 4,The compressor insulation fault.	1,Check the air-conditioner system; 2,Change the driver board; 3, Change the Compressor; 4, Change the Compressor.
6	Communication between driver board and control board fault	1,Communication wire connect not well; 2,Driver board fault; 3,Control board fault;	1, Check compressor wire connect. 2,Change the driver board; 3,Change the control board ;
7	AC voltage,overload voltage	1,Supply voltage input too high or too low; 2,Driver board fault;	1,Check power supply; 2,Change the driver board;
8	DC voltage,overload voltage	1,Supply voltage input too high ; 2,Driver board fault;	1,Check power supply; 2,Change the driver board;
9	AC voltage imbalance	Driver board fault;	Change the driver board;
10	The current detection circuit fault	Bad driver board components;	Change the driver board
11	AC voltage supply in	1,Power supply abnormal, power frequency out of range; 2,Driver board fault;	1,Check the system; 2,Change the driver board;
12	Products of single-phase PFC over-current, FO output low level	1,System overload, current too large; 2,Driver board fault; 3,PFC fault.	1,Check the system; 2,Change the driver board; 3,Change PFC.
13	Inverter over current (3-phase power supply air conditioners)	1,System overload, current too large; 2,Driver board fault; 3, Compressor oil shortage, serious wear of crankshaft; 4,The compressor insulation fault.	1,Check the system; 2,Change the driver board; 3, Change the Compressor; 4, Change the Compressor.
14	Inverter over current	1,System overload, current too large; 2,Driver board fault; 3,Compressor oil shortage,serious wear of crankshaft; 4,The compressor insulation fault.	1,Check the system; 2,Change the driver board; 3, Change the Compressor; 4, Change the Compressor.

7. TROUBLE SHOOTING

Fault code	Fault Description	Possible Reason of Abnormality	How to Deal With
15	PFC over current(single-phase air-conditioner)	1, System overload, current too large; 2, Driver board fault; 3, PFC fault..	1, Check the system; 2, Change the driver board; 3, Change PFC.
16	Phase imbalance or phase lacks or the instantaneous power failure (only for 3-phase power supply air conditioners)	1, 3-Phase voltage imbalance; 2, The 3-phase power supply phase lost; 3, Power supply wiring wrong; 4, Driver board fault.	1, Check the power supply; 2, Check the power supply; 3, Check the power supply wiring connect; 4, Change the driver board.
17	The instantaneous power failure detection	1, The power supply is not stable ; 2, The instantaneous power failure ; 3, Driver board fault;	1, Check the power supply . 2, Not fault. 3, Change the driver board;
18	Low DC voltage 200V	1, Voltage input too low ; 2, Driver board fault.	1, Check the power supply . 2, Change the driver board.

li: Driver board fault codes trouble shooting (**ONLY FOR 20K&16K DUAL TYPES**), details see sheet6.
2-seconds long LED flash on/off in means number 5, 1 -second short LED flash on/off means number 1.

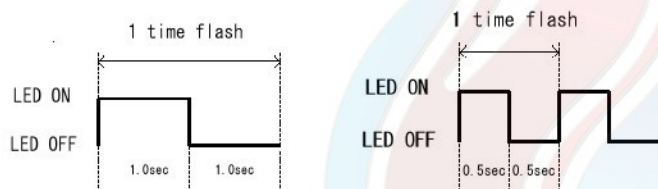

For example, fault code 4: Indicator light flash 4 times 1-second short LED on/off intervals for a period of time again, reports No. 4 fault.

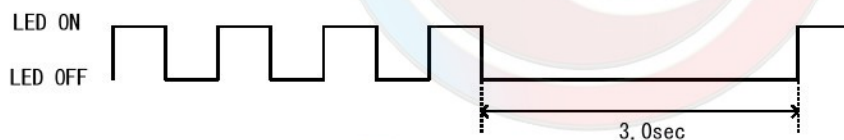

For example, fault code 11: Indicator light flash 2 times 2-seconds long LED on/off and 1 time 1-second long LED on/off intervals for a period of time again, reports No. 11 fault.



Sheet 6 Driver Error Code

-----Only for 20K&16 Dual types

Fault code	Fault Description	Possible Reason of Abnormality	How to Deal With
1	Inverter DC voltage overload fault	1、 Power supply input too high or too low; 2、 Driver board fault.	1, Check power supply 2, Change driver board.
2	Inverter DC low voltage fault		
3	Inverter AC current overload fault		
4	Out-of-step detection	1、 Compressor phase lost;	1, Check compressor wire

7. TROUBLE SHOOTING

Fault code	Fault Description	Possible Reason of Abnormality	How to Deal With
5	Loss phase detection fault (speed pulsation)	2、 Bad driver board components; 3、 The compressor insulation fault	connect; 2,Change driver board; 3,Change compressor.
6	Loss phase detection fault (current imbalance)		
7	Inverter IPM fault (edge)	1、 System overload or current overload; 2,Driver board fault. 3,Compressor oil shortage, serious wear of crankshaft 4、 The compressor insulation fault	1、 Check the system . 2、 Change driver board; 3、 Change the compressor; 4、 Change the compressor.
8	Inverter IPM fault (level)		
9	PFC_IPM IPM fault (edge)		
10	PFC_IPM IPM fault (level)		
11	PFC power detection of failure	1、 The power supply is not stable ; 2、 The instantaneous power failure ; 3、 Driver board failure.	1、 Check the power supply. 2、 Not abnormal. 3、Change the driver board.
12	PFC overload current detection of failure.	1、 System overload, current too high; 2、 Driver board failure; 3、 PFC failure;	1、 Check the system; 2、Change the driver board; 3、 Change the PFC.
13	DC voltage detected abnormal .	1、 Input voltage is too high or too low; 2,Driver board failure;	1,Check the power supply . 2,Change the driver board;
14	PFC LOW voltage detected failure.		
15	AD offset abnormal detected failure.	Driver board failure.	Change the driver board.
16	Inverter PWM logic set fault.		
17	Inverter PWM initialization failure		
18	PFC_PWM logic set fault.		
19	PFC_PWM initialization fault.		
20	Temperature abnormal.		
21	Shunt resistance unbalance adjustment fault		
22	Communication failure.	1、 Communication wire connect not well. 2、 Driver board failure. 3、 Control board failure.	1、 Check the wiring. 2、 Change the driver board. 3、 Change the control board.
23	Motor parameters setting of failure	Initialization abnormal.	Reset the power supply.

8. CHECKING COMPONENTS

8-1. Check refrigerant system

TEST SYSTEM FLOW

Conditions: ① Compressor is running.

② The air condition should be installed in good ventilation.

Tool: Pressure Gauge

Technique: ① see ② feel ③ test

SEE ----- Tube defrost.

FEEL ----- The difference between tube's temperature.

TEST ----- Test pressure.

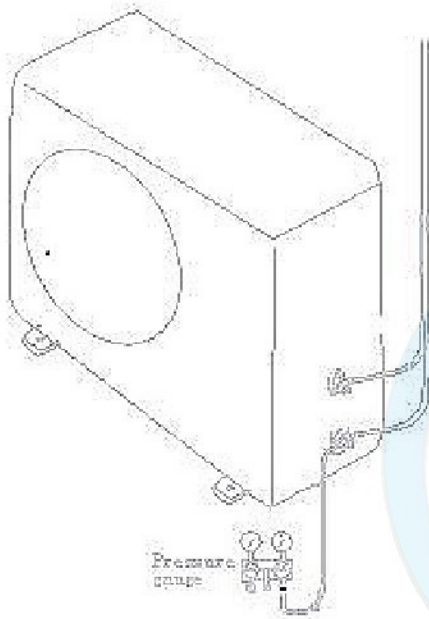

دما پویا

8. CHECKING COMPONENTS

Test system flow

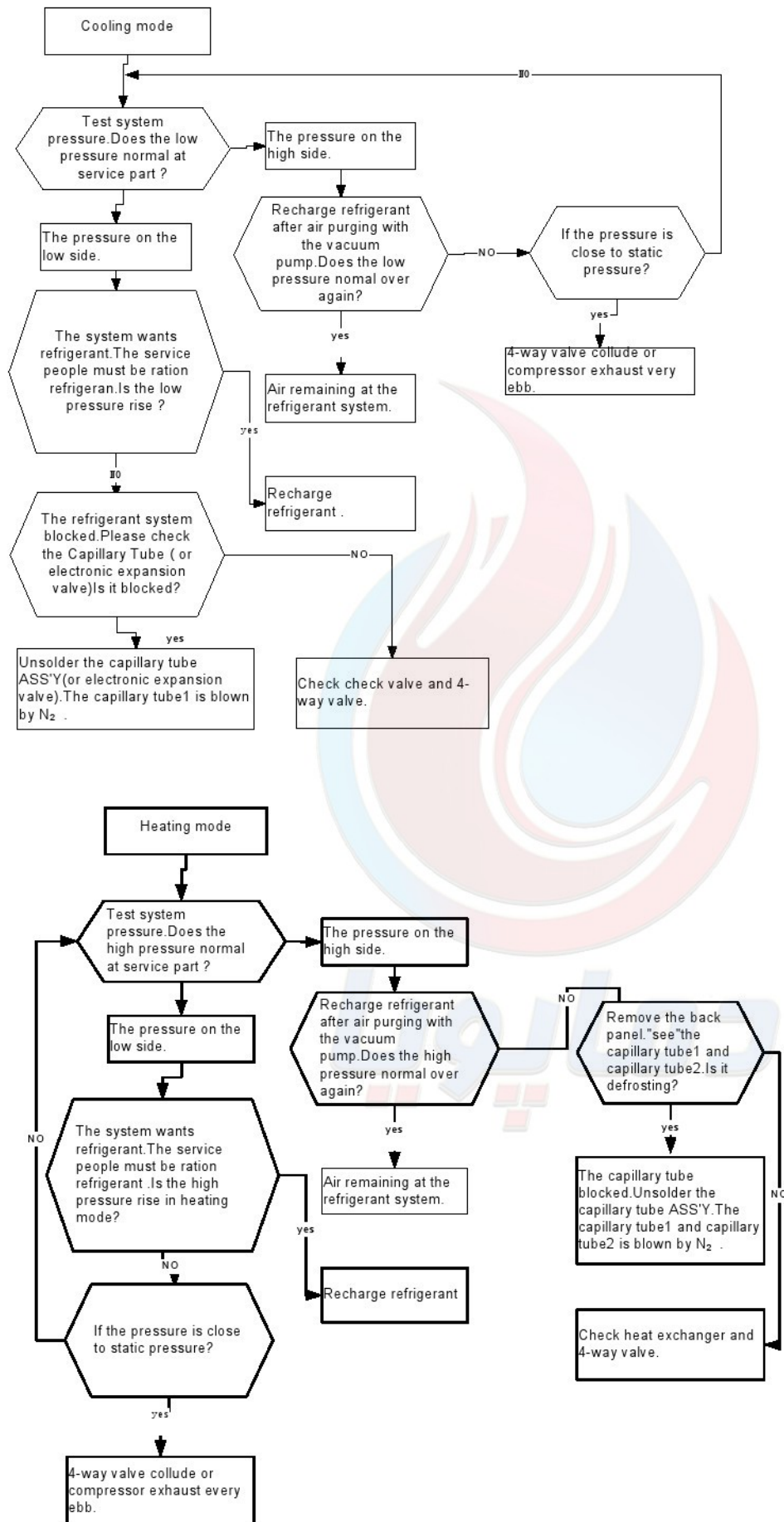

8. CHECKING COMPONENTS

8-2. Check parts unit

1. INDOOR FAN MOTOR

MOTOR EXAMINE AND REPAIR

Circuit diagram :

DUCT TYPE

18K

YSK95-45-4-B

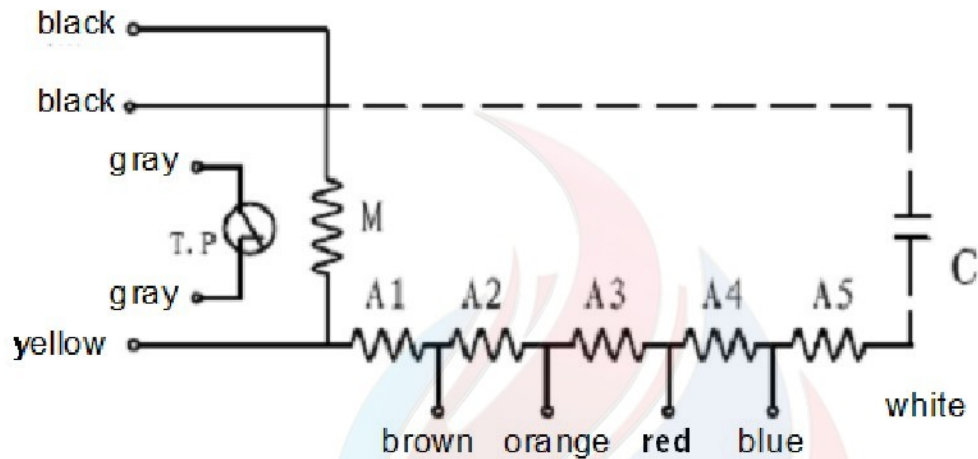

M1:138 Ω A1: 42.5 Ω A2:22 Ω A3:17.6 Ω A4:14.6 Ω A5:81.4 Ω

24K

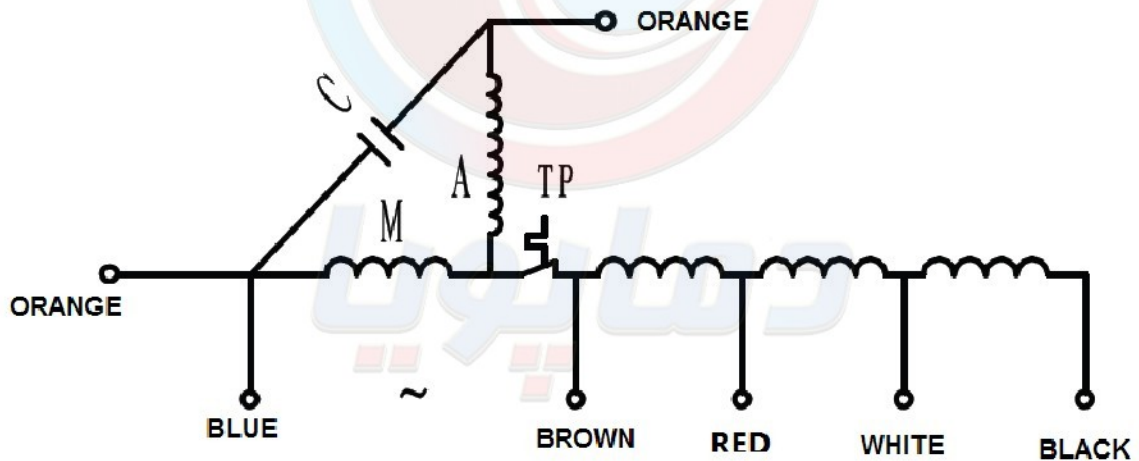

BROWN-BLUE:70.1

BROWN-ORANGE:75.5

BROWN-RED:10.3

RAD -WHITE:11.4

WHITE-BLACK:16.1

8. CHECKING COMPONENTS

36K

Y7S423B814

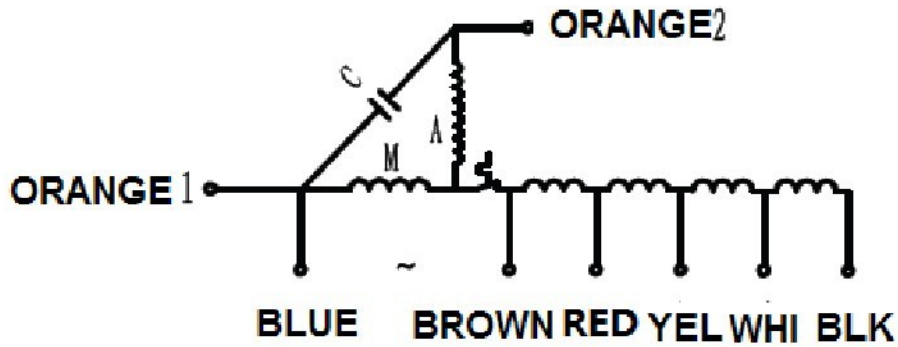

BLUE- BROWN:52.5

BROWN-RED:3.78

RAD -YELLOW:3.68

YELLOW-WHITE:0.89

WHITE-BLACK:4.67

ORANGE- BROWN:29.5

48K,60K

Y7S423C237

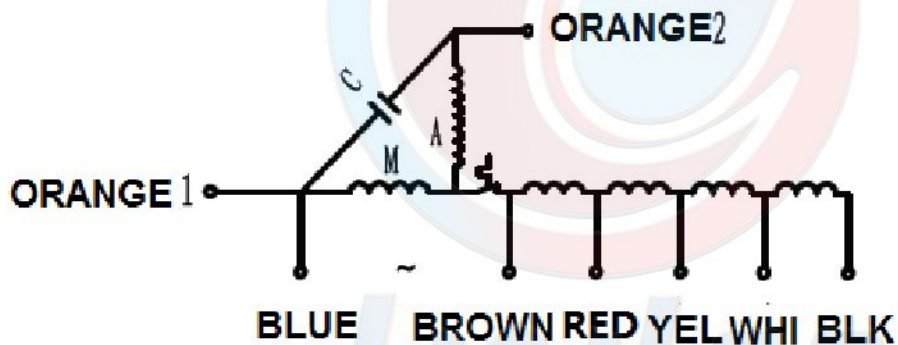

BLUE- BROWN:17.89

ORANGE1- BROWN:27.2

BROWN-RED:3.35

RAD -WHITE:4.77

WHITE-BLACK:2.72

8. CHECKING COMPONENTS

CASSETTE TYPE

18K

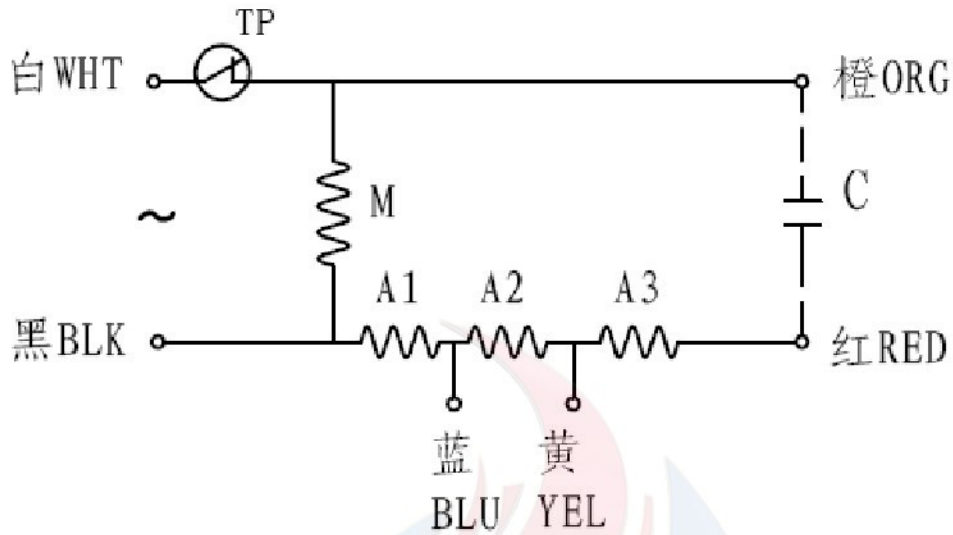

M:240 Ω A1:60 Ω A2:33 Ω A3:143 Ω

24K

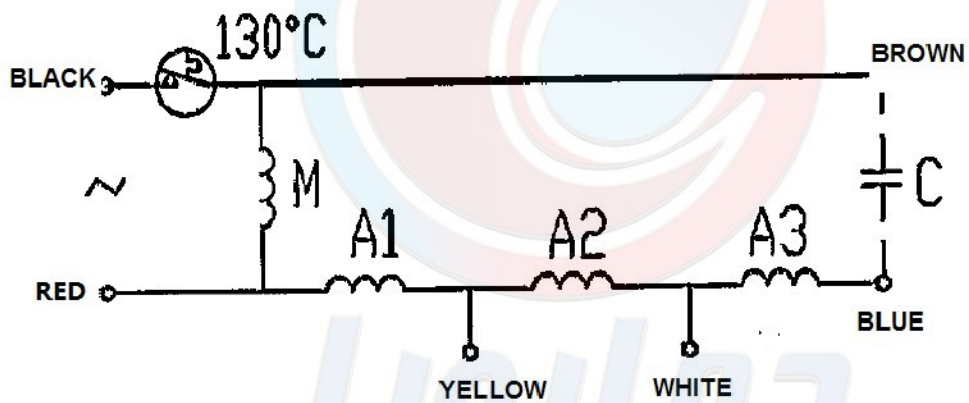

M:209.4 Ω A1:36.2 Ω A2:51.5 Ω A3:109.2 Ω

36K

YDK75-8-2

M:75 Ω A:97.5 Ω

8. CHECKING COMPONENTS

48K&60K
YDK80-8-2

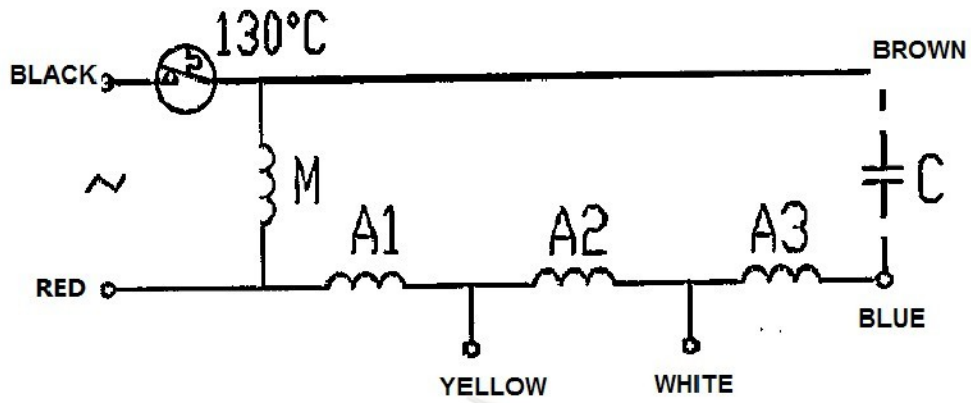

M: 75Ω A: 97.5Ω



8. CHECKING COMPONENTS

Ceiling&Floor type

MOTOR EXAMINE AND REPAIR

Circuit diagram :

18K

YSK110-22-4-A

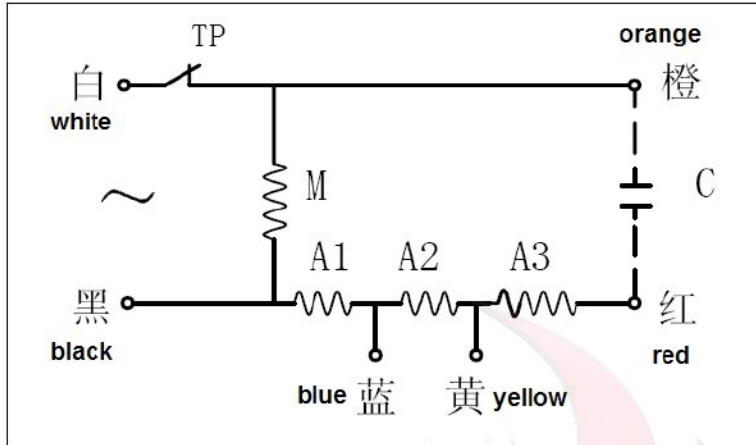

M: 187 Ω A1: 37.5 Ω A2: 27.8 Ω A3: 146 Ω

24K

YSK110-100-4-A

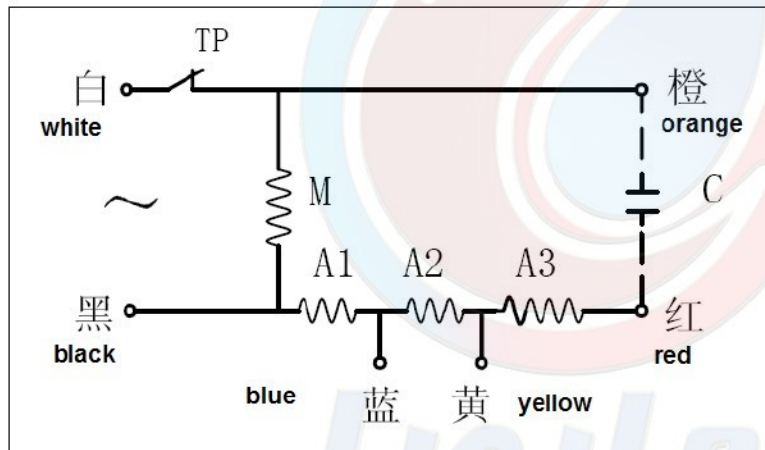

M:55 Ω A1:23.2 Ω A2:10.9 Ω A3:18.3 Ω

8. CHECKING COMPONENTS

36K

Y7S423B212

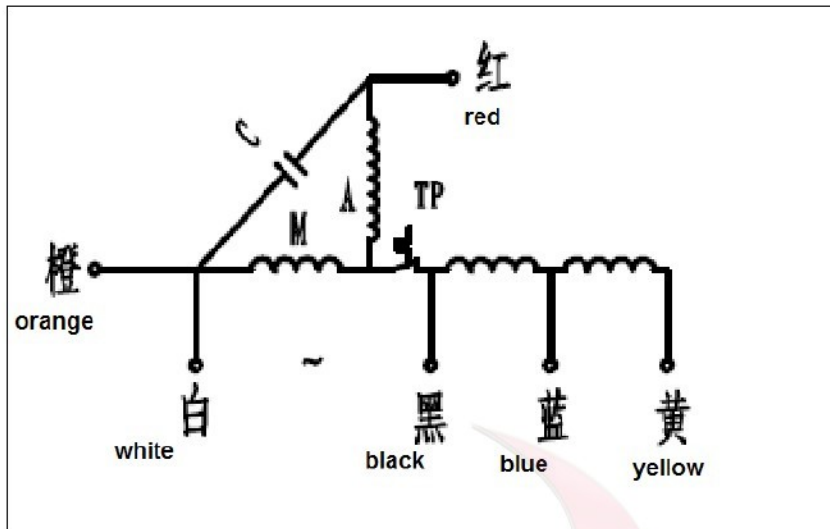

WHITE-BLACK:41.49 BLACK-BLUE:13.25 BLUE-YELLOW:12.39
 RED-BLACK:35.21

48K&60K

Y7S423C032

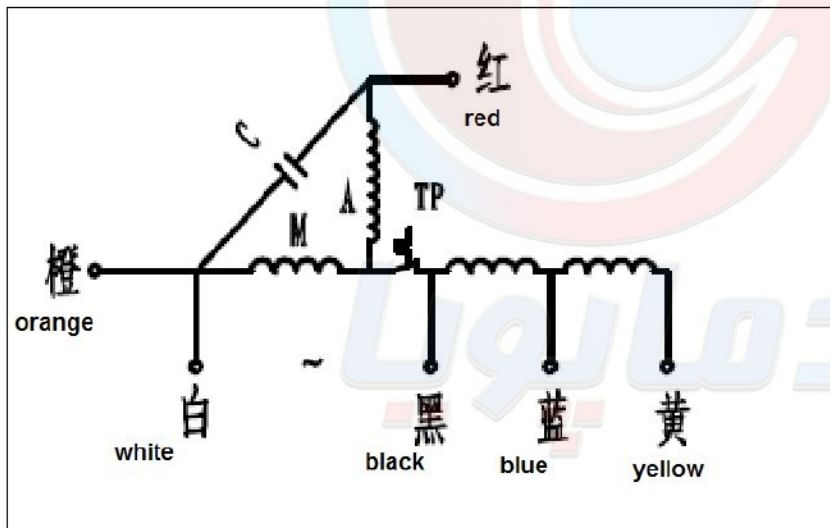

WHITE-BLACK:42.69 BLACK-BLUE:9.19 BLUE-YELLOW:9.09
 RED-BLACK:36.41

Test in resistance.

TOOL: Multimeter.

Test the resistance of the main winding. The indoor fan motor is fault if the resistance of main winding 0(short circuit)or ∞ (open circuit) .

Test in voltage

TOOL: Multimeter.

8. CHECKING COMPONENTS

Insert screwdriver into to rotate indoor fan motor slowly for 1 revolution or over, and measure voltage "YELLOW" and "GND" on motor. The voltage repeat 0V DC and 5V DC.

Notes:

- 1) Please don't hold motor by lead wires.
- 2) Please don't plug IN/OUT the motor connector while power ON.
- 3) Please don't drop hurl or dump motor against hard material. Malfunction may not be observed at early stage after such shock. But it may be found later, this type of mishandling void our warranty.



8. CHECKING COMPONENTS

2. OUTDOOR FAN MOTOR

MOTOR EXAMINE AND REPAIR

Circuit diagram

18K

YDK29-6I-25

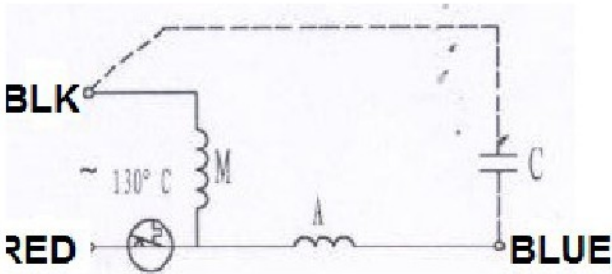

Winding resistance (at 20°C)

M: 231 Ω A: 168 Ω

24K

YDK70-6H-3:

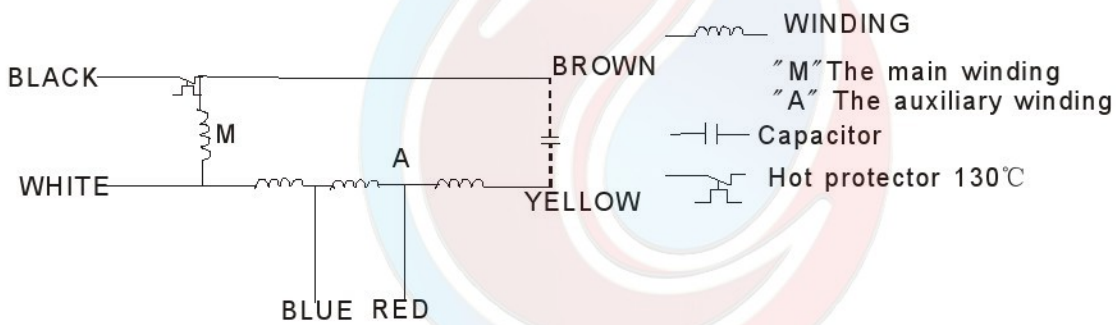

Winding resistance (at 20°C)

M: 78 Ω A: 80 Ω

36K

YDK95-6-9043

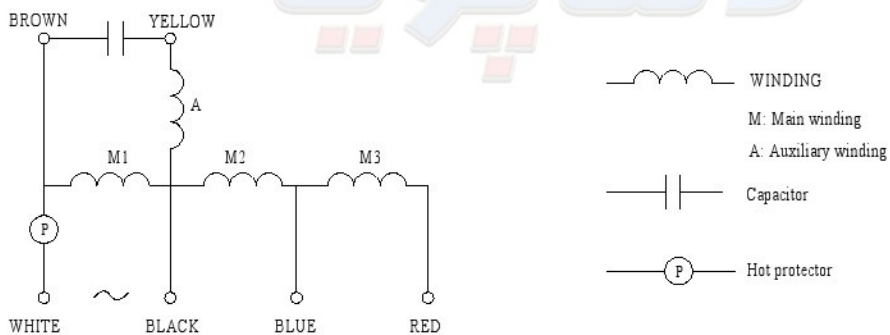

Winding resistance (at 20°C)

M1:59.1 Ω M2:20.3 Ω M3:15.3 Ω A: 85.8 Ω

8. CHECKING COMPONENTS

48K

YDK29-6I-39

YDK29-6I-41

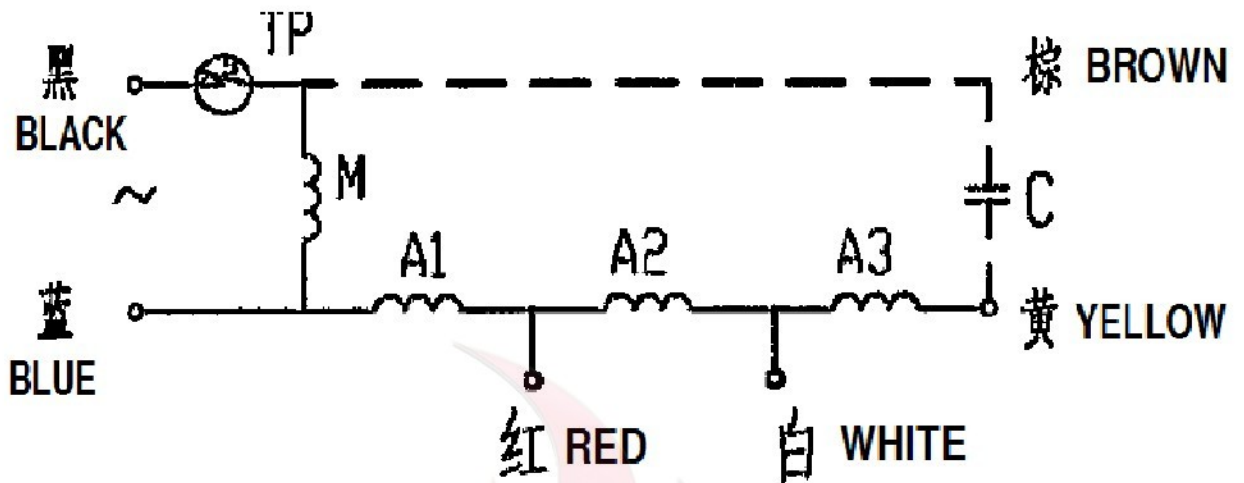

Winding resistance (at 20°C)

M:187 Ω ± 15%

A:BLUE-RED-WHITE-YELLOW 50/21/106 Ω ± 15%

60K

YDK65-6-9024、YDK65-6-9061

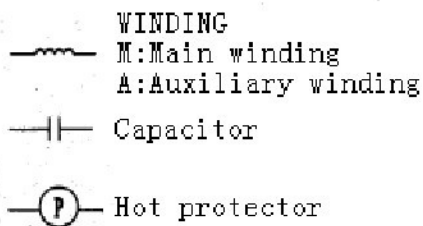
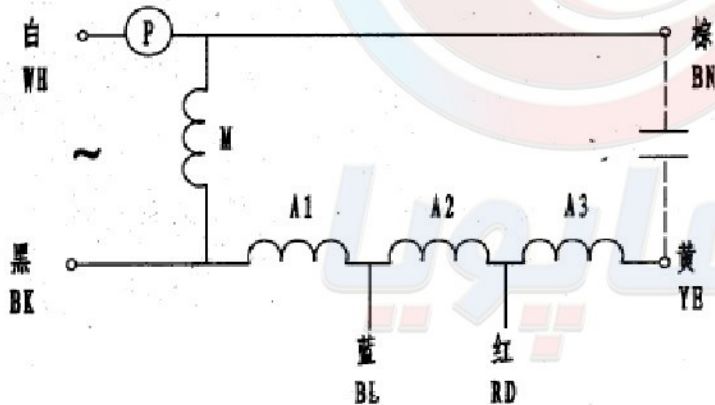

Winding resistance (at 20°C)

M:83.0 Ω A1:23.4 Ω A2:14.0 Ω A3: 63.5 Ω

8. CHECKING COMPONENTS

Test in resistance.

TOOL: Multimeter.

Test the resistance of the main winding. The outdoor fan motor is fault if the resistance of main winding 0(short circuit)or ∞ (open circuit) .

Notes:

- 1) Please don't hold motor by lead wires.
- 2) Please don't plug IN/OUT the motor connecter while power ON.
- 3) Please don't drop hurl or dump motor against hard material. Malfunction may not be observed at early stage after such shock. But it may be found later, this type of mishandling void our warranty.



8. CHECKING COMPONENTS

3. COMPRESSOR

COMPRESSOR EXAMINE AND REPAIR

18K

PA190M2CS-4KTL

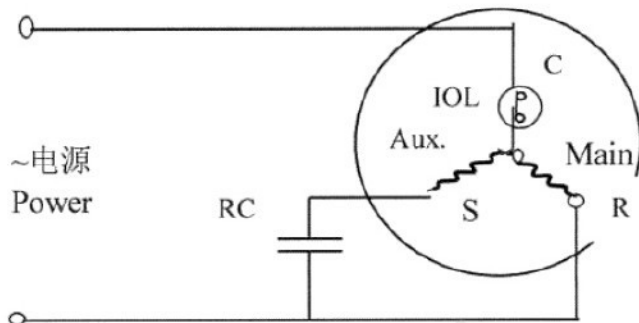

S: START (辅绕组 AUX WINDING)

R: RUN (主绕组 MAIN WINDING)

C: COMMON (共通)

RC: 运转电容 RUNNING CAPACITOR

IOL: 内置保护器 Internal Overload Protector

24K

PA290G2CS-4MUL1

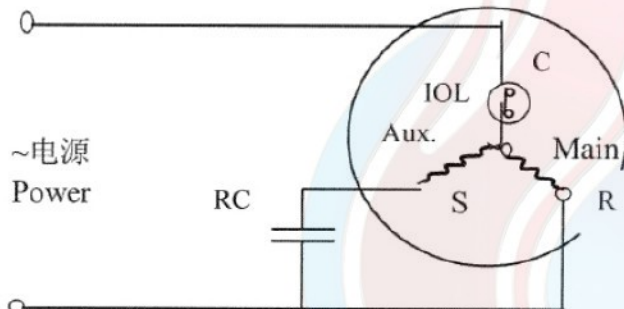

S: START (辅绕组 AUX WINDING)

R: RUN (主绕组 MAIN WINDING)

C: COMMON (共通)

RC: 运转电容 RUNNING CAPACITOR

IOL: 内置保护器 Internal Overload Protector

36K

C-SBN303H8D

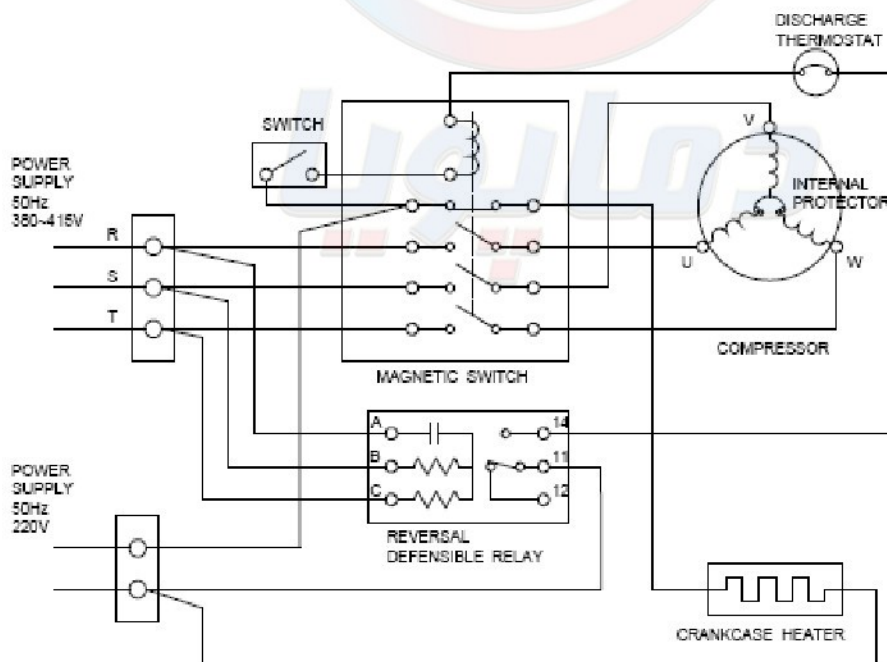

8. CHECKING COMPONENTS

ATH420UC-C9EU

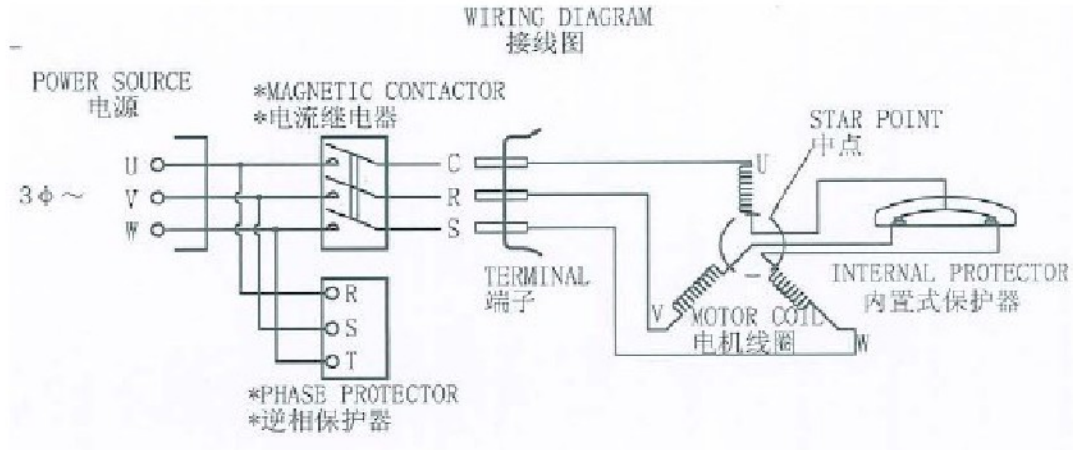

48K

LOW-Ambient Temperature Type

ATE550SC3Q9RK

R

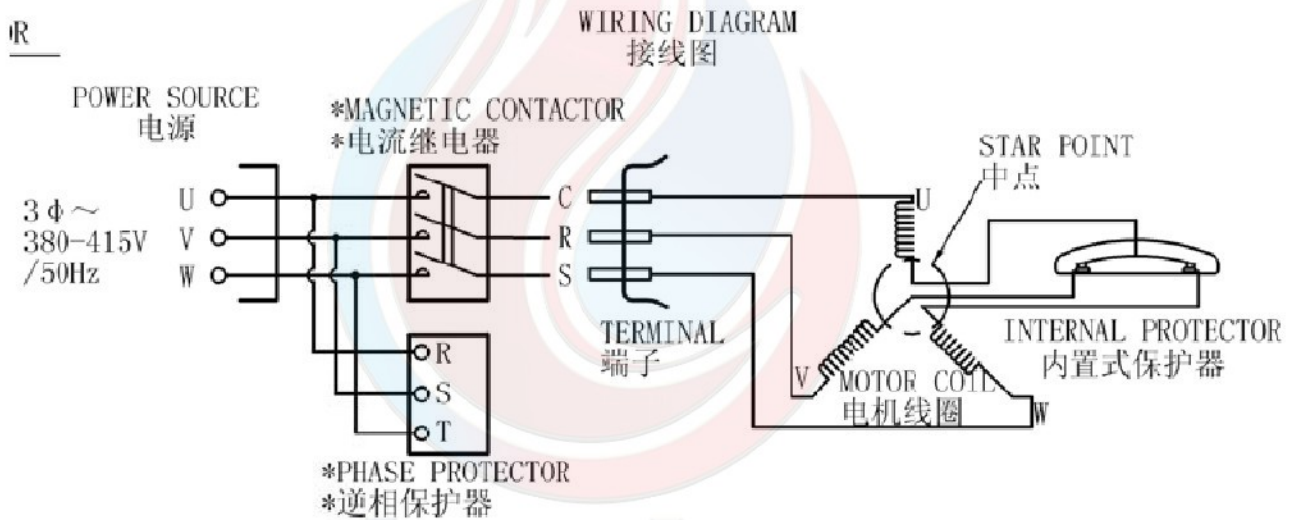

48K

Ordinary Temperature Type

60K

C-SBN453H8D

8. CHECKING COMPONENTS

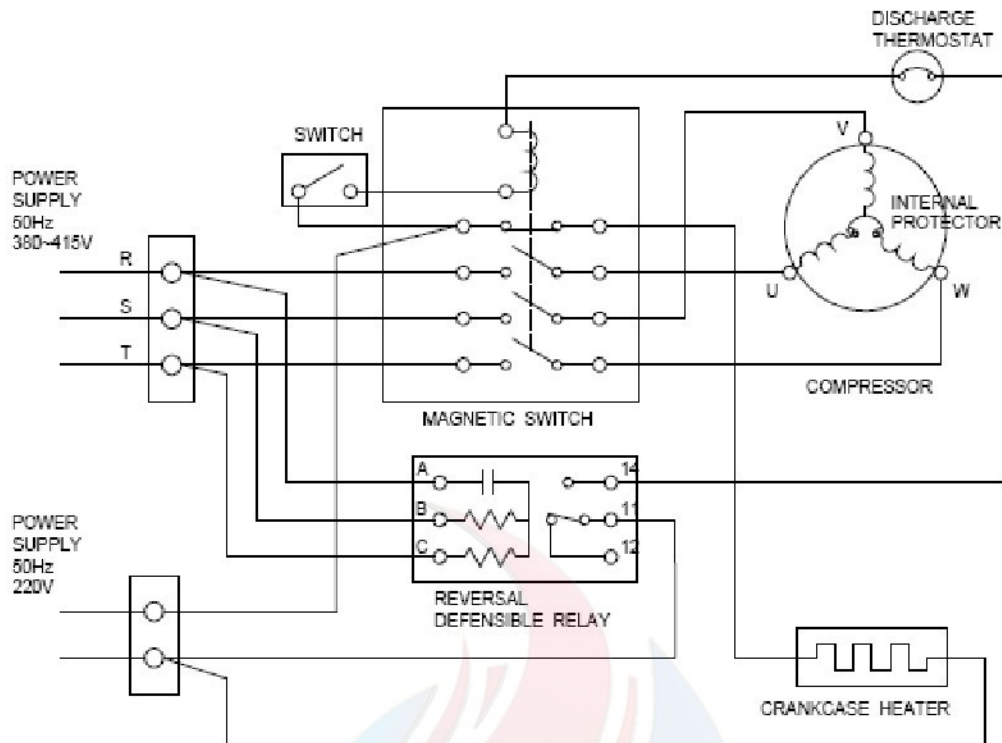

Test in resistance.

TOOL: Multimeter.

Test the resistance of the winding. The compressor is fault if the resistance of winding 0(short circuit)or ∞ (open circuit)

Familiar error:

- 1) Compressor motor lock.
- 2) Discharge pressure value approaches static pressure value .
- 3) Compressor motor winding abnormality.

Notes:

- 1) Don't put a compressor on its side or turn over.
- 2) Please assembly the compressor in your air conditioner rapidly after removing the plugs. Don't place the comp. In air for along time.
- 3) Avoiding compressor running in reverse caused by connecting electrical wire incorrectly.
- 4) Warning! In case AC voltage is impressed to compressor, the compressor performance will below because of its rotor magnetic force decreasing.

4. INDUCTANCE

Familiar error:

- 1) Sound abnormality
- 2) Insulation resistance disqualification.

8. CHECKING COMPONENTS

5. STEP MOTOR

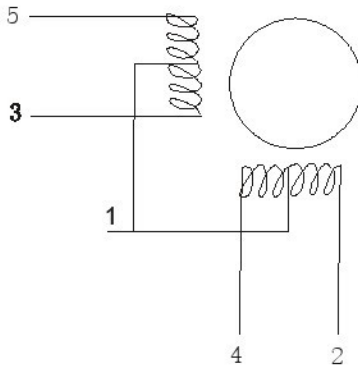

Test in resistance.

TOOL: Multimeter.

Test the resistance of winding. The stepper motor is fault if the resistance of winding 0(short circuit) or ∞ (open circuit) .

6. FUSE

Checking continuity of fuse on PCB ASS'Y.

- 1) Remove the PCB ASS'Y from the electrical component box. Then pull out the fuse from the PCB ASS'Y (Fig.1)

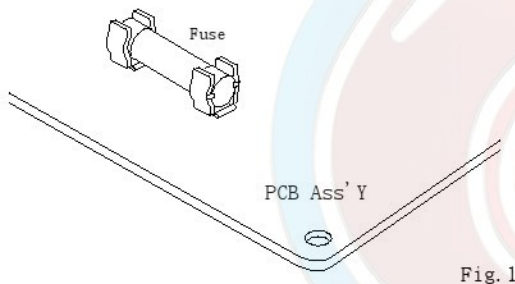

Fig.1

- 2) Check for continuity by a multimeter as shown in Fig.2.

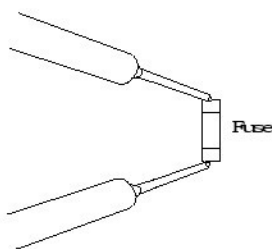

Fig 2

7. CAPACITOR

- 1) Remove the lead wires from the capacitor terminals, and then place a probe on the capacitor terminals as shown in Fig.3.
- 2) Observe the deflection of the pointer, setting the resistance measuring range of the multimeter to the maximum value.
 - * The capacitor is "good" if the pointer bounces to a great extent and then gradually returns to its original position.
 - * The range of deflection and deflection time differ according to the capacity of the capacitor.

8. CHECKING COMPONENTS

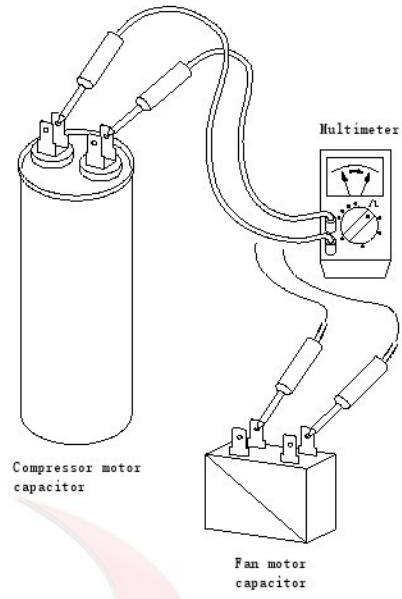

Fig. 3

